





42115 LAMBORGHINI SIÁN FKP 37

Copy writer: Scott Selkirk Neillands

Graphic design: Henriette Solgaard, Kristian Nørby Larsen

Packaging concept: Dan Kjærsgaard, Natacha Héléne Marie Lesty

Studio photography: Tim Trøjborg, Syrine Maj Pallisby

Location photography: Büro Jantzen, Automobili Lamborghini

BOOK ONE  BUCH EINS

Videocasts only available in English
Videocasts nur in englischer Sprache verfügbar

Booklet available in English on
Livret disponible en français sur
Libretto disponibile in italiano su
Folleto disponible en español en
如需中文版手册, 请访问

LEGO.com/service/buildinginstructions

TWO DISTINCT COMPANIES WITH A SHARED PASSION FOR PERFECTION

ZWEI VERSCHIEDENE UNTERNEHMEN –
GEEINT IM STREBEN NACH PERFEKTION

There may be a long way from Denmark to Italy, but this is the story of how LEGO® Technic and Automobili Lamborghini came together to create the LEGO Technic version of the iconic Lamborghini Sián FKP 37.

Diese Geschichte erzählt, wie LEGO® Technic und Automobili Lamborghini trotz der weiten Entfernung zwischen Dänemark und Italien zusammenfanden, um die LEGO Technic Version des kultverdächtigen Lamborghini Sián FKP 37 zu erschaffen.





Automobili Lamborghini. Sant'Agata Bolognese, Italy

automobili
Lamborghini

SANT'AGATA BOLOGNESE - ITALIA









EVERY LEGO® TECHNIC MODEL IS A SPECIAL JOURNEY

JEDES LEGO® TECHNIC MODELL BESCHREITET
EINEN BESONDEREN WEG

Uwe Wabra / Senior Designer / LEGO® Technic

Recreating any vehicle in LEGO® Technic is much more than just finding the right LEGO elements. Our designers have to understand the unique story of the real car and the company that created it. They have to discover the intentions of the original designer and the reason behind each detail. Every LEGO Technic model is a special journey. This is the story of our version of the Lamborghini Sián FKP 37.

Das Nachbilden eines Fahrzeugs als LEGO® Technic Modell ist weitaus aufwendiger, als nur die richtigen LEGO Elemente zu finden. Unsere Designer müssen zuerst die einzigartige Geschichte des echten Autos und seines Herstellers verinnerlichen. Sie müssen herausfinden, welche Absichten der ursprüngliche Designer verfolgte und welchen Zweck jedes einzelne Detail erfüllt. Jedes LEGO Technic Modell beschreitet einen besonderen Weg. Das ist die Geschichte unserer Version des Lamborghini Sián FKP 37.



Meet the LEGO® Technic design team and learn how they kick off a project like this.

Hier lernen Sie das LEGO® Technic Designteam kennen und erfahren, wie die Designer ein solches Projekt angehen.

> www.LEGO.com/lamborghini-sian/videocasts



UWE WABRA
Senior Designer / LEGO® Technic



“

**I NEVER PLANNED ON GETTING INTO
THE AUTOMOBILE INDUSTRY, BUT I
KNEW A BETTER CAR COULD BE BUILT**
ICH HATTE NIE VOR, IN DIE AUTOINDUSTRIE ZU
GEHEN, ABER ICH WUSSTE IMMER, DASS EIN
BESSERES AUTO GEBAUT WERDEN KÖNNTE

Ferruccio Lamborghini / Founder of Automobili Lamborghini



Follow the design team as they explore
the Polo Storico at Automobili Lamborghini.

*Begleiten Sie das Designteam durch den
Polo Storico bei Automobili Lamborghini.*

> www.LEGO.com/lamborghini-sian/videocasts



1971 Lamborghini Miura P400 S

Ferruccio Lamborghini made his fortune constructing tractors, but his real passion was for powerful sports cars. Believing the ultimate automobile had yet to be created, he decided to do it himself. Paolo Gabrielli knows everything about Lamborghini's history and was the perfect person to tell our designers about the principles that guided Ferruccio Lamborghini and why he chose the "Raging Bull" as the symbol for his first supercar.

Ferruccio Lamborghini hat sein Vermögen mit der Fertigung von Traktoren gemacht, aber eigentlich schlug sein Herz für leistungsstarke Sportwagen. In der festen Überzeugung, dass das ultimative Auto erst noch entwickelt werden müsste, beschloss er, diese Aufgabe selbst anzupacken. Paolo Gabrielli weiß alles über die Geschichte von Lamborghini und war der perfekte Gesprächspartner, um unsere Designer in die Grundsätze einzuweihen, von denen sich Ferruccio Lamborghini leiten ließ, und uns darüber aufzuklären, warum Ferruccio den „wütenden Stier“ als Emblem für seinen ersten Supersportwagen auswählte.





63

Lamborghini

SIÁN

P ZERO



MITJA BORKERT

Head of Design / Automobili Lamborghini



OUR MOTTO IS "EXPECT THE UNEXPECTED"
UNSER MOTTO LAUTET „ERWARTE DAS UNERWARTETE“

Mitja Borkert / Head of Design / Automobili Lamborghini

With its unmistakable design DNA, dramatic proportions and hexagon design elements, you are never in any doubt that you are standing in front of a Lamborghini. Mitja Borkert, Head of Design at Automobili Lamborghini, demonstrated to our design team what makes a Lamborghini a Lamborghini and explained the story and design heritage behind the Lamborghini Sián FKP 37.

Die unverwechselbare Design-DNA, die spektakulären Proportionen und die sechseckigen Designelemente lassen keinen Zweifel, dass Sie vor einem Lamborghini stehen. Mitja Borkert, Head of Design bei Automobili Lamborghini, demonstrierte unserem Designteam, was einen Lamborghini zu einem Lamborghini macht, und erzählte uns, welche Geschichte und welches Designvermächtnis dem Sián FKP 37 zugrunde liegen.



Watch as the two design teams come together at the Centro Stile in Sant'Agata Bolognese.

Sehen Sie sich an, wie die beiden Designteam im Centro Stile in Sant'Agata Bolognese zusammenkommen.

> www.LEGO.com/lamborghini-sian/videocasts





**IT HAS TO LOOK LIKE IT'S MOVING,
EVEN WHEN IT'S STANDING STILL**

**ES MUSS SO AUSSEHEN, ALS OB ES SICH
BEWEGT – SELBST WENN ES STEHT**

Eminel Hodžić / Senior Exterior Designer / Automobili Lamborghini

It's the precise match of neat edges, sleek lines and sensual surfaces that gives each Lamborghini model its own dynamic personality. Senior Exterior Designer at Lamborghini Centro Stile, Eminel Hodžić, sculpted the outer form of the Lamborghini Sián FKP 37 and illustrated to the LEGO® Technic designers how such a visionary design can take inspiration from the past.

Es sind die exakt aufeinander abgestimmten sauberen Kanten, eleganten Linien und sinnlichen Oberflächen, die jedem Lamborghini-Modell seine eigene Persönlichkeit verleihen. Eminel Hodžić, Senior Exterior Designer bei Lamborghini Centro Stile, hat die äußere Form des Lamborghini Sián FKP 37 gestaltet und den LEGO® Technic Designern erläutert, wie sich ein derart visionäres Design von der Vergangenheit inspirieren lässt.

Watch Automobili Lamborghini designer Eminel Hodžić's reaction to the LEGO® Technic model.

Sehen Sie sich die Reaktion des Designers Eminel Hodžić von Automobili Lamborghini auf das erste LEGO® Technic Modell an.

> www.LEGO.com/lamborghini-sian/videocasts





EMINEL HODŽIĆ
Senior Exterior Designer
Automobili Lamborghini





VITTORIO GABBA
Head of Ad Personam
& Special Series
Automobili Lamborghini



DETAILS MAKE PERFECTION AND PERFECTION ISN'T A DETAIL
DETAILS MACHEN PERFEKTION AUS, ABER PERFEKTION IST KEIN DETAIL

Vittorio Gabba / Head of Ad Personam & Special Series / Automobili Lamborghini

They say no two Lamborghinis are exactly the same, and this is especially true for the Sián FKP 37. Only a limited number of them will ever be made, and each one will be finished to the specific wishes of its owner. Vittorio Gabba heads up the Ad Personam studio at Automobili Lamborghini and took the LEGO® Technic designers through all the many choices an owner has to customise their Sián FKP 37.

Es heißt, keine zwei Lamborghini seien exakt gleich, und das gilt insbesondere für den Sián FKP 37. Dieses Modell wird nur in begrenzter Anzahl gebaut, und jedes Exemplar wird nach den besonderen Wünschen des künftigen Besitzers angefertigt. Vittorio Gabba leitet das Ad Personam Studio bei Automobili Lamborghini. Er zeigte den LEGO® Technic Designern die zahlreichen Optionen, die dem künftigen Besitzer zur Auswahl stehen, um den Sián FKP 37 nach den eigenen Vorstellungen zu gestalten.



See the LEGO® Technic designers explore the Ad Personam studio.

Sehen Sie zu, wie die LEGO® Technic Designer das Ad Personam Studio erkunden.

> www.LEGO.com/lamborghini-sian/videocasts





“

**IT'S NOT JUST THE LOOKS, IT'S THE SPIRIT
OF THE SIÁN FKP 37 I HAD TO CAPTURE**

ES GEHT NICHT NUR UMS AUSSEHEN. ICH MUSSTE
DAS GANZE WESEN DES SIÁN FKP 37 EINFANGEN

Uwe Wabra / Senior Designer / LEGO® Technic

“

WE ARE ALWAYS LOOKING TOWARDS THE NEW FRONTIER FOR CAR TECHNOLOGY
WIR WOLLEN STETS DIE GRENZEN DER AUTOMOBILTECHNIK VERSCHIEBEN

Maurizio Reggiani / Chief Technical Officer / Automobili Lamborghini





The Sián FKP 37 is the first Lamborghini hybrid model where electric power is combined with the company's epic V12 engine to boost performance and efficiency. Maurizio Reggiani is Chief Technical Officer at Automobili Lamborghini and was able to tell the LEGO® designers how the company strives to deliver super-cars that combine ultimate performance with pure emotion.

Der Sián FKP 37 ist das erste Hybridmodell von Lamborghini, in dem ein Elektromotor mit dem legendären V12-Motor des Unternehmens kombiniert wird, um eine bessere Leistung und Effizienz zu erzielen. Maurizio Reggiani, Chief Technical Officer bei Automobili Lamborghini, konnte den LEGO® Designern einen Einblick geben, wie es dem Unternehmen gelingt, Supersportwagen zu entwickeln, die ultimative Leistung und pure Emotion in sich vereinen.

MAURIZIO REGGIANI
Chief Technical Officer / Automobili Lamborghini

Follow the step-by-step construction of the iconic Lamborghini V12 engine.

Schauen Sie zu, wie Schritt für Schritt ein legendärer V12-Motor von Lamborghini entsteht.

> www.LEGO.com/lamborghini-sian/videocasts





LAMBORGHINI IS REFINEMENT, LUXURY AND PERFECTION LAMBORGHINI STEHT FÜR FINESSE, LUXUS UND PERFEKTION

Ferruccio Lamborghini / Founder of Automobili Lamborghini

The Lamborghini production facility in Sant'Agata Bolognese doesn't look like a conventional car factory and it doesn't function like one either. Each car is individually hand-built, one at a time. As Ranieri Niccoli, Chief Manufacturing Officer, explained to the LEGO® Technic design team, this is the only way the company can ensure the level of perfection the founder, Ferruccio Lamborghini, demanded every Lamborghini must have.

Die Produktionsstätte von Lamborghini in Sant'Agata Bolognese sieht nicht wie ein konventionelles Autowerk aus – und sie funktioniert auch ganz anders. Jedes Auto wird von Hand gebaut – und zwar immer eines nach dem anderen. Ranieri Niccoli, Chief Manufacturing Officer, erklärte dem LEGO® Technic Design-Team, dass dieses Maß an Perfektion, das der Firmengründer Ferruccio Lamborghini von jedem Lamborghini verlangte, sonst nicht zu erzielen sei.



Join the LEGO® Technic designers on a tour of the Automobili Lamborghini production facility.

Begleiten Sie die LEGO® Technic Designer auf eine Besichtigungstour durch die Produktionsstätte von Automobili Lamborghini.

> www.LEGO.com/lamborghini-sian/videocasts







RANIERI NICCOLI
Chief Manufacturing Officer / Automobili Lamborghini

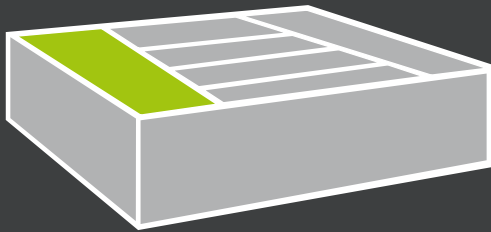

BOX ONE  BOX EINS



GEARBOX & REAR SUSPENSION GETRIEBE & HINTERRADAUFHÄNGUNG

It seemed a shame to go to all the trouble of simulating the intricate gearbox of the real Lamborghini Sián FKP 37, only to hide it away under other elements and sections of the model. Therefore, Senior Designer Uwe Wabra decided to create small 'windows' on the bottom of the model that allow you to see the gearing system work.

Es wäre doch schade gewesen, das komplizierte Getriebe des Lamborghini Sián FKP 37 mit großem Aufwand nachzubilden, nur um es dann unter anderen Elementen und Baugruppen des Modells verschwinden zu lassen. Deshalb beschloss Senior Designer Uwe Wabra, an der Unterseite des Modells kleine 'Fenster' einzubauen, damit Sie sehen können, wie das Getriebe funktioniert.



> www.LEGO.com/lamborghini-sian/videocasts

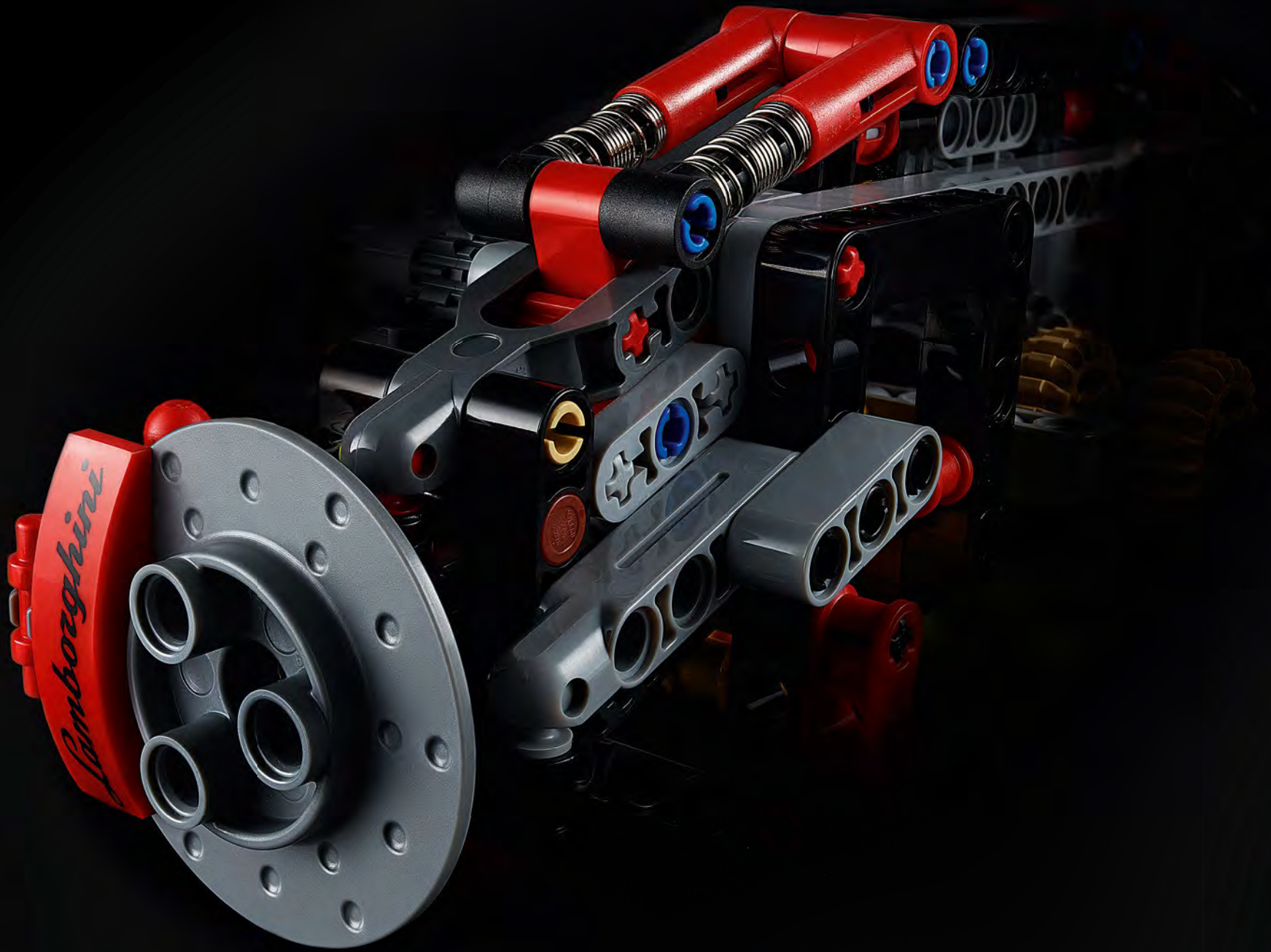

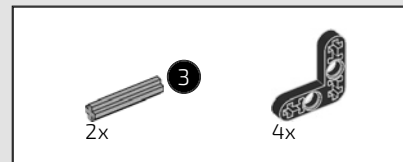
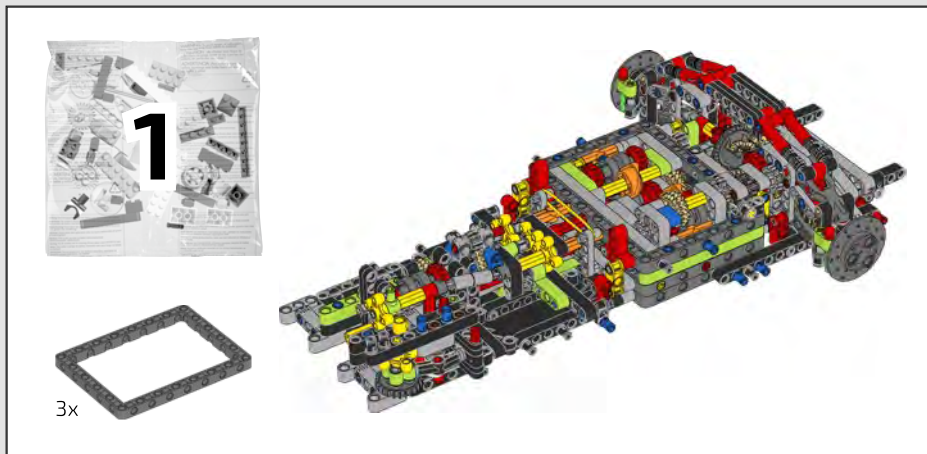

2



1

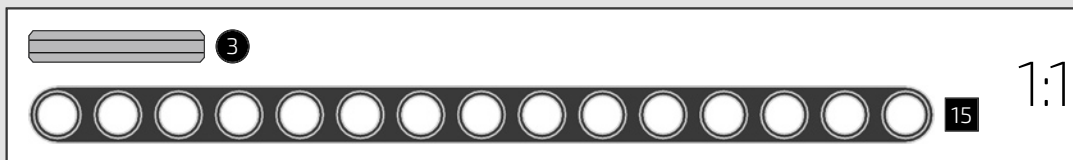
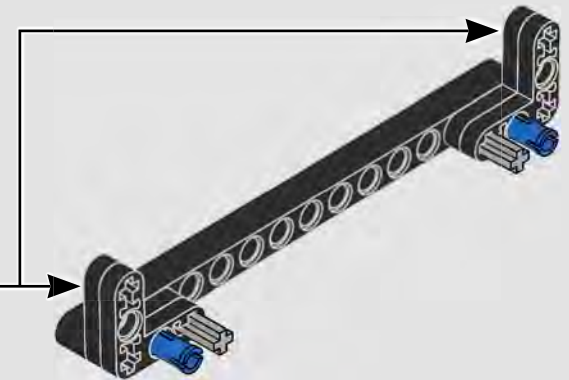
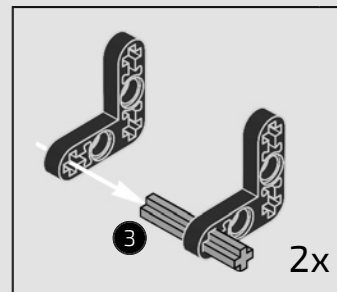

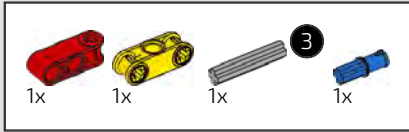

3

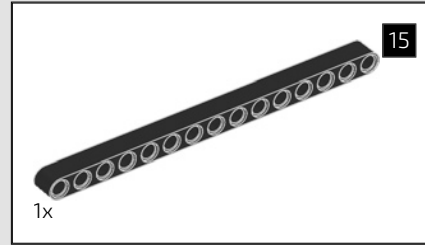
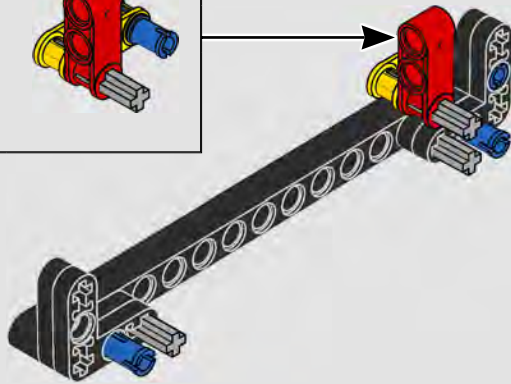
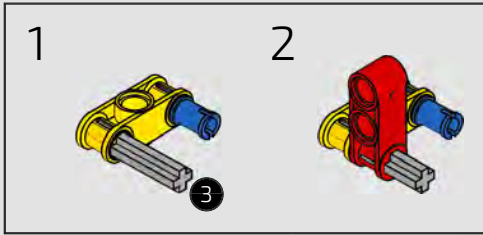

4

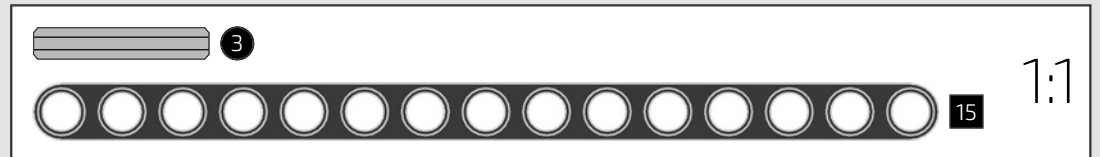
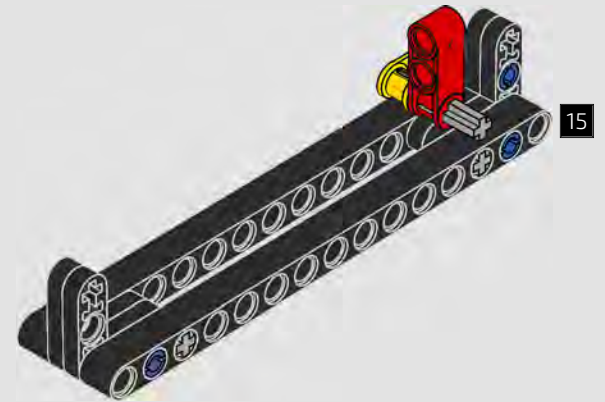



5

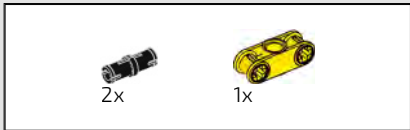
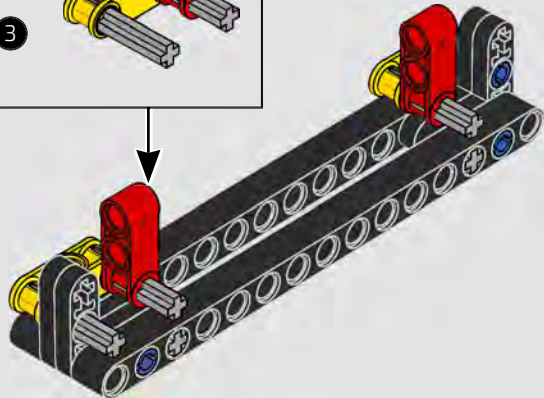
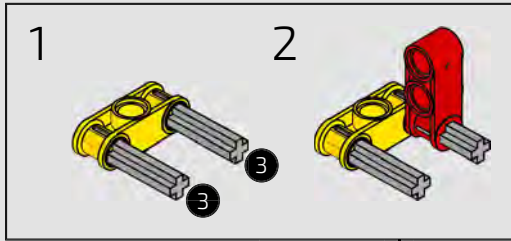

6

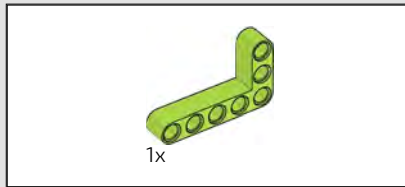
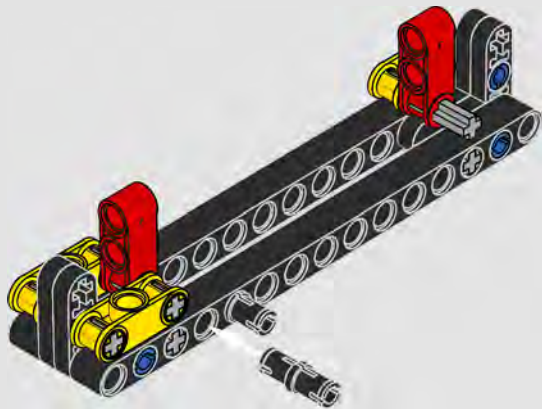

7

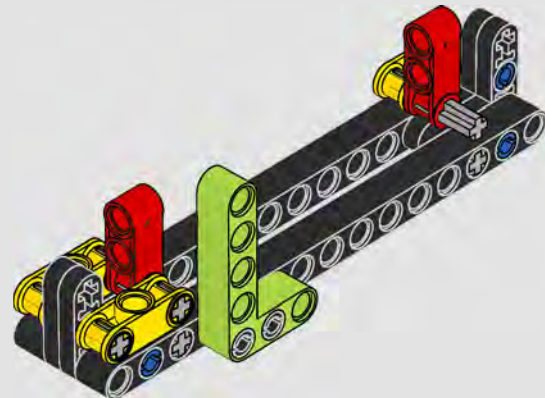

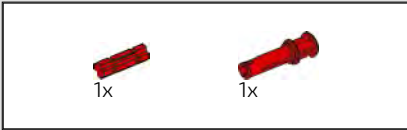

8

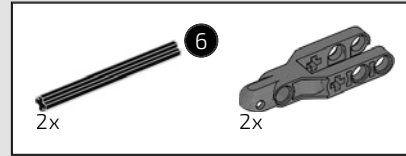
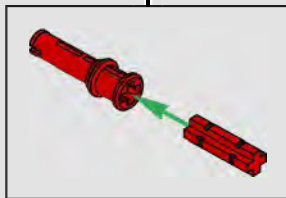
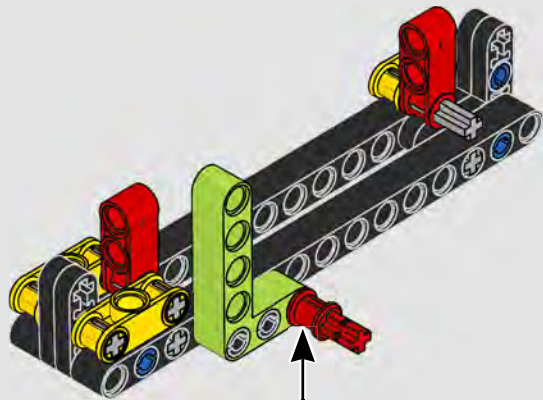

9

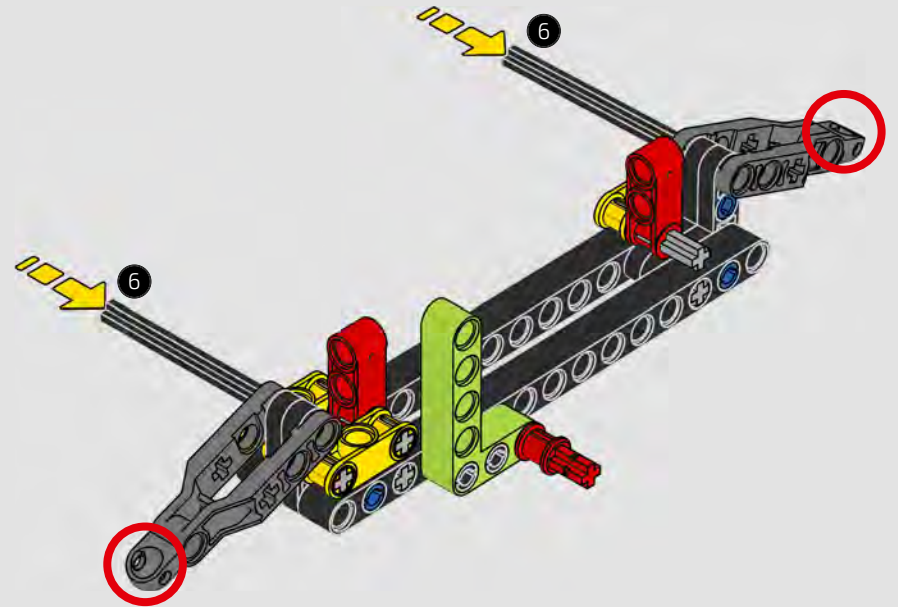
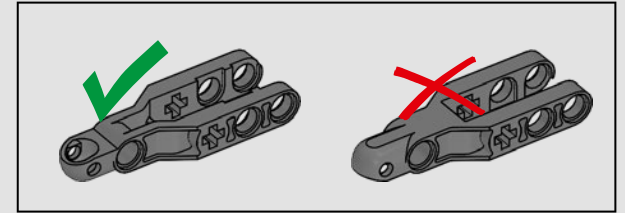



10

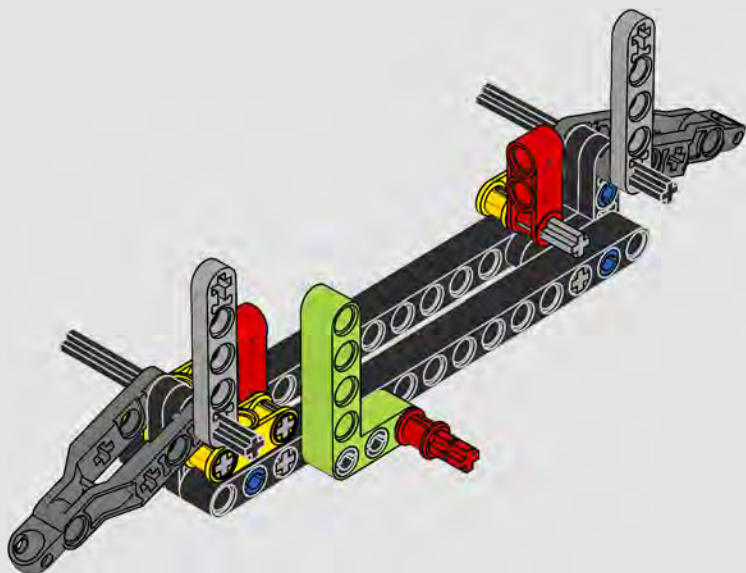

11

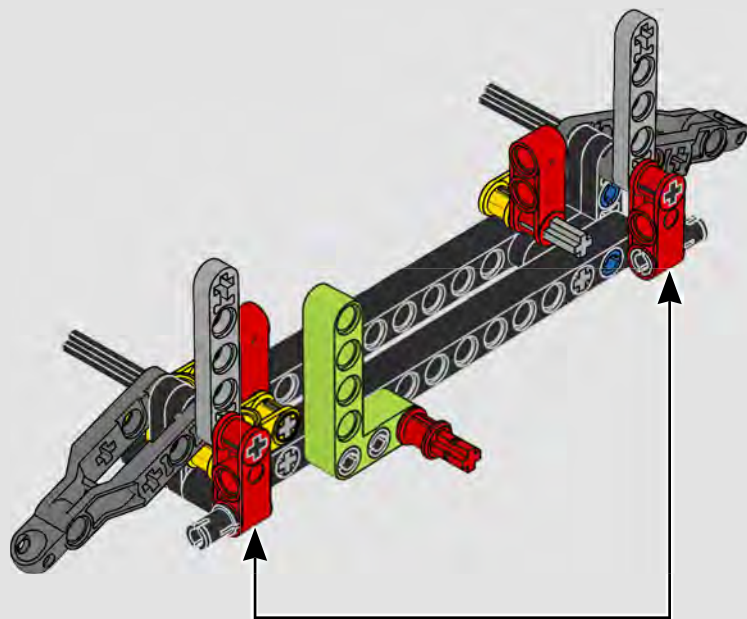

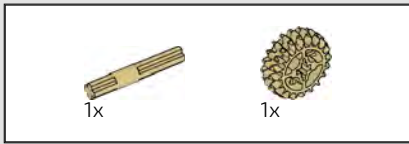

12

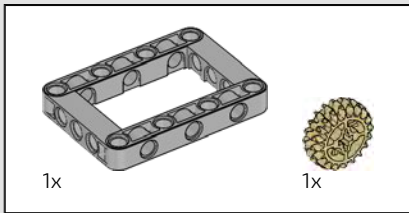
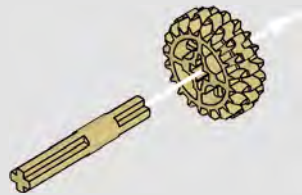

13

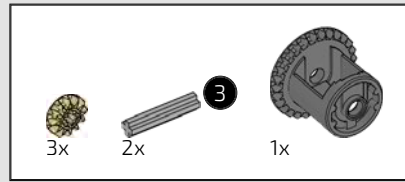
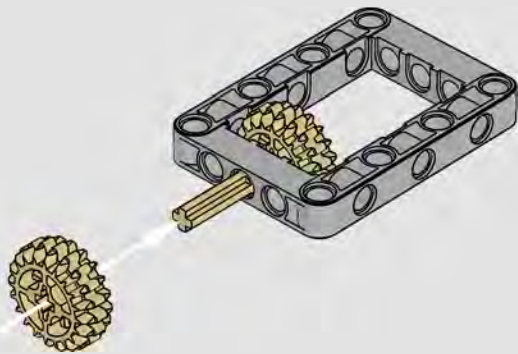

14

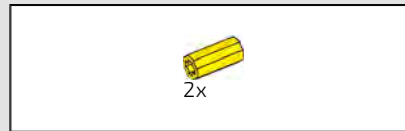
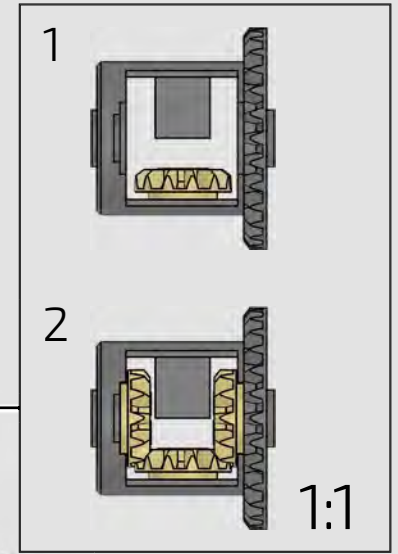
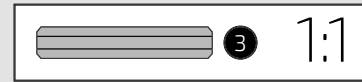
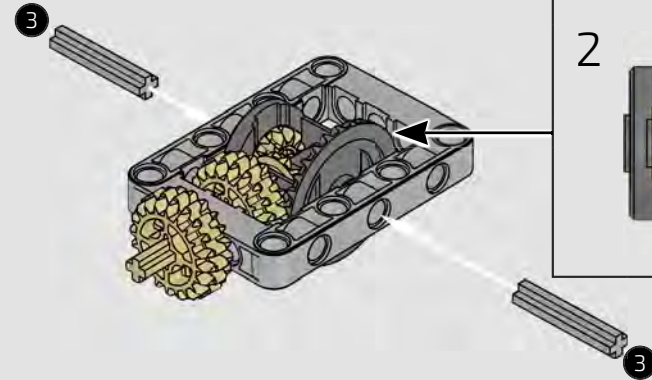

15

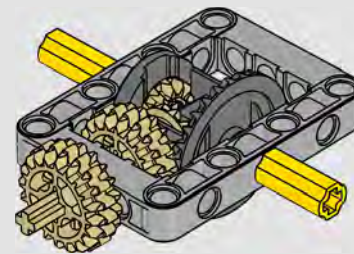

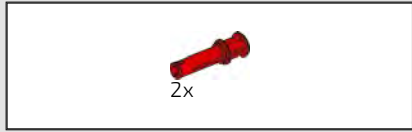

16

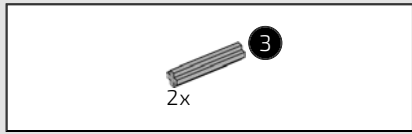
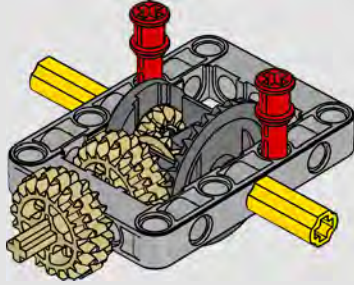

17

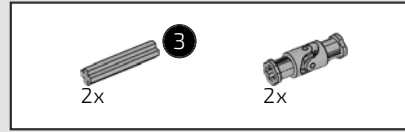
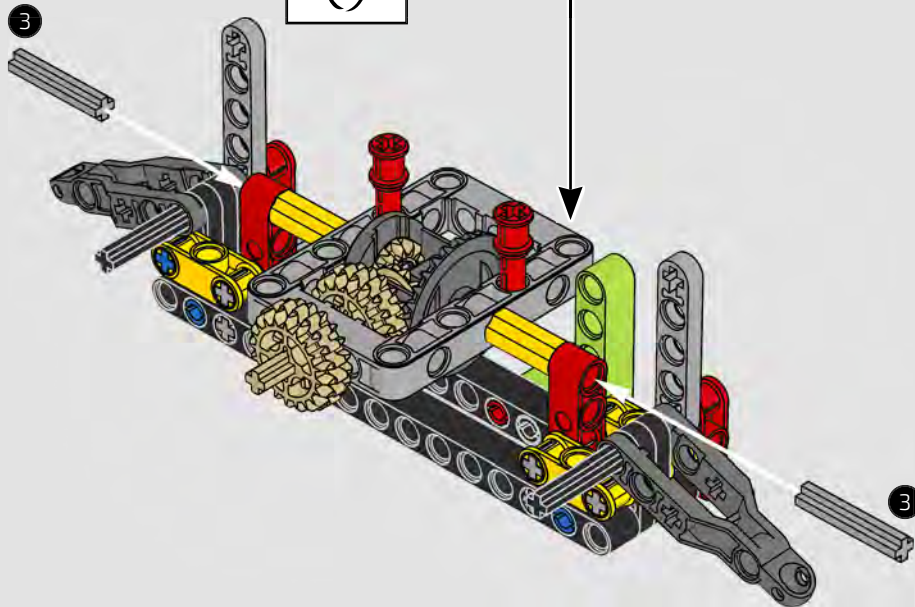

18

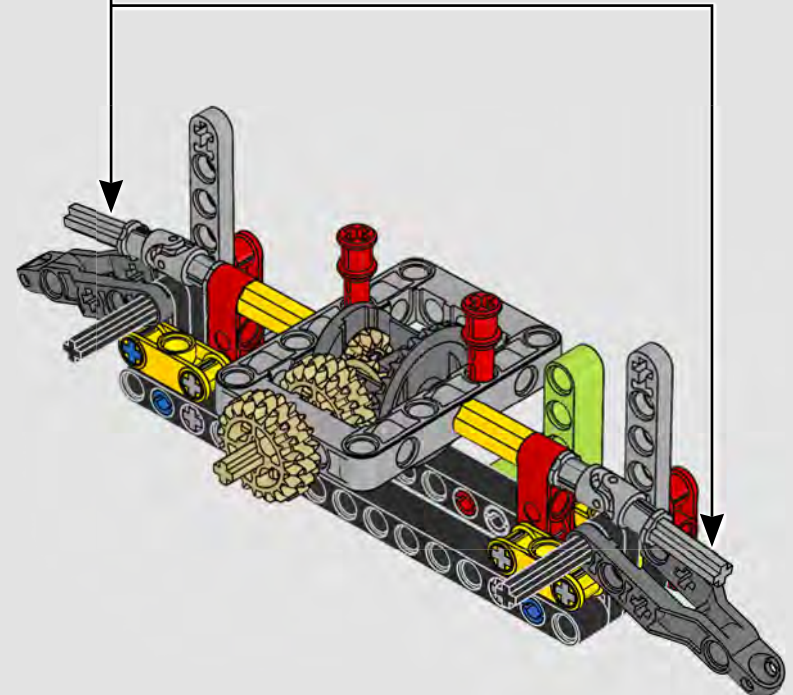
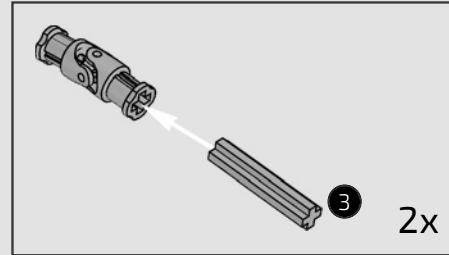
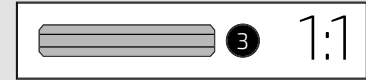

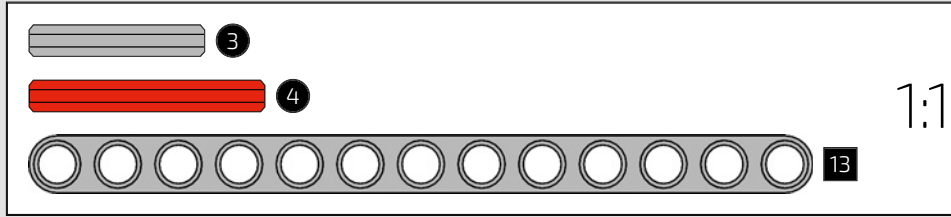
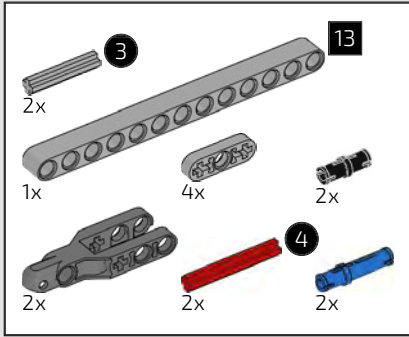

19

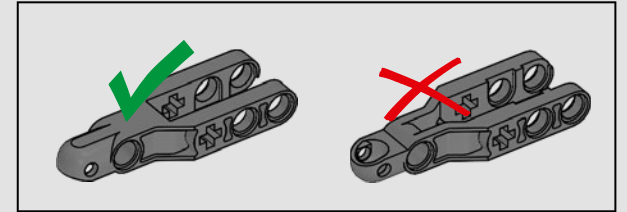
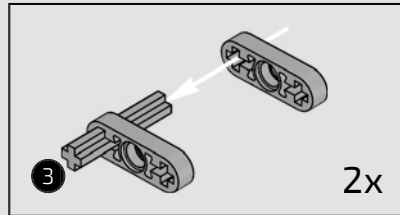

1

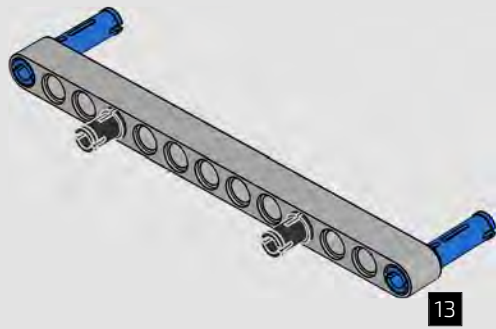

2

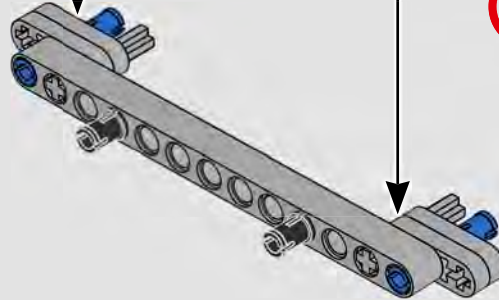

3

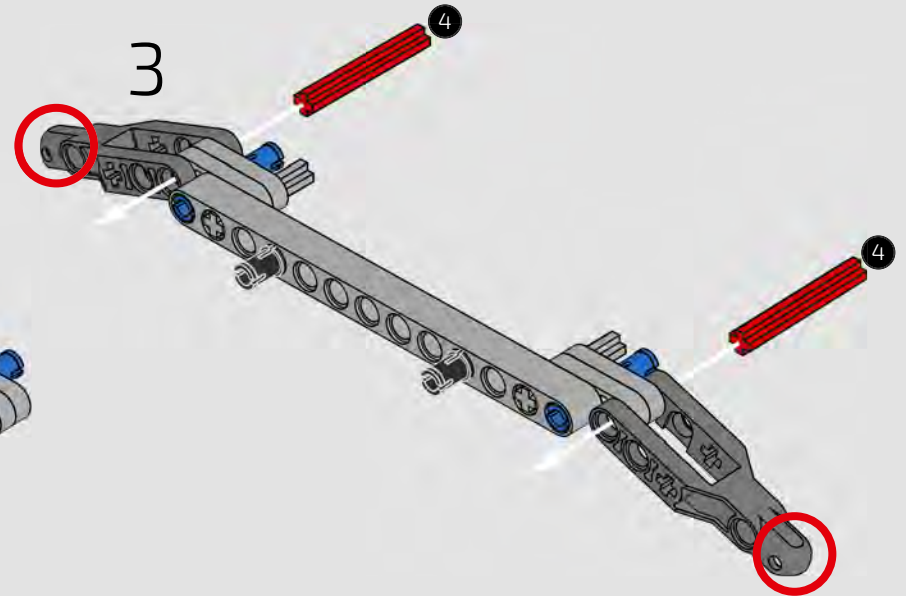

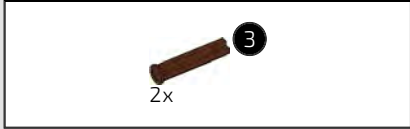
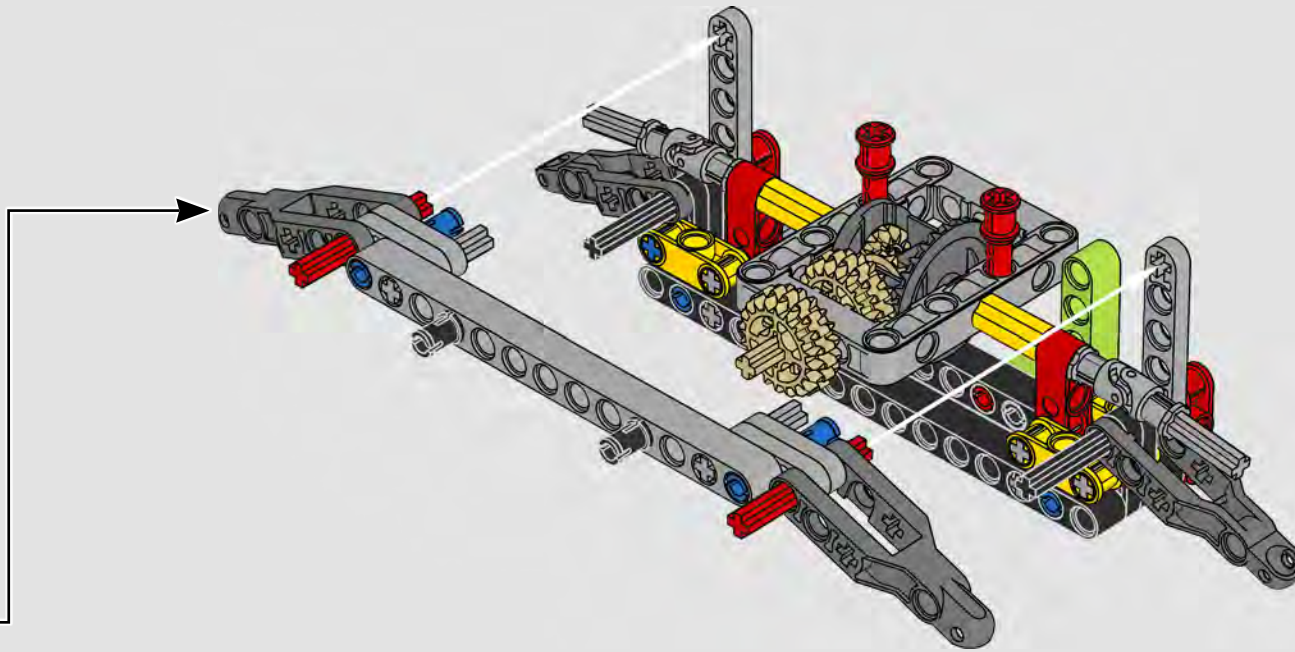

20

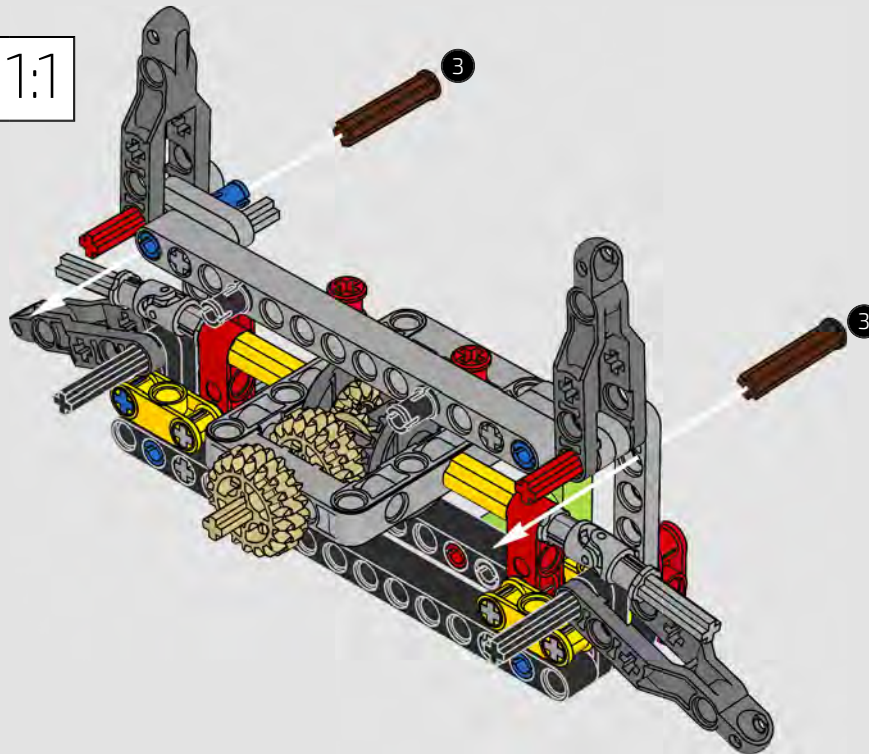

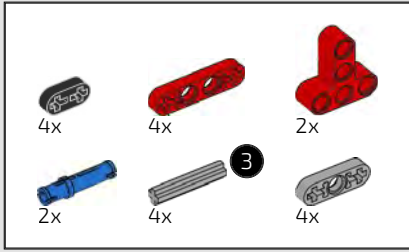

21

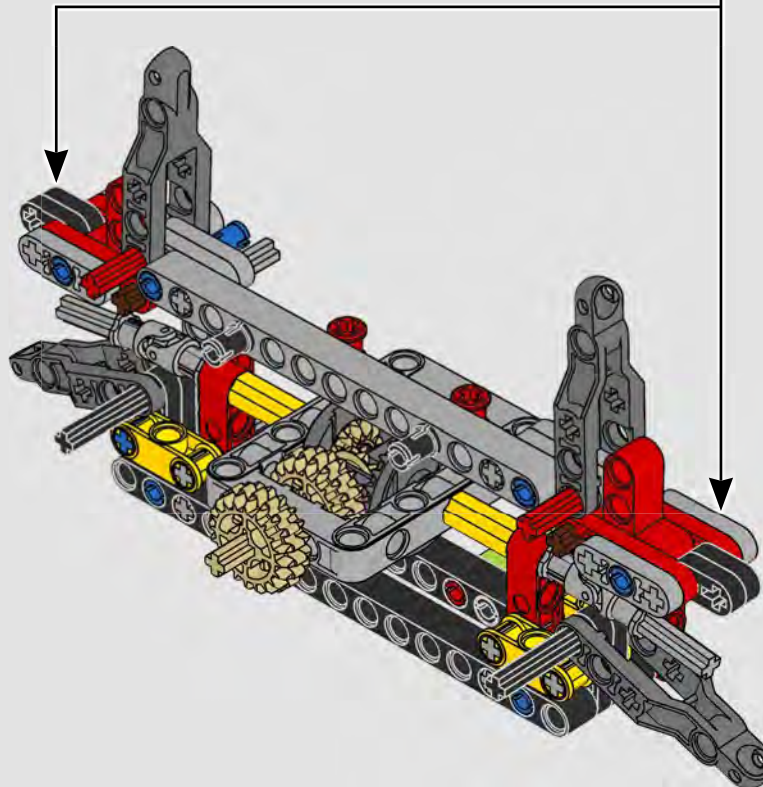
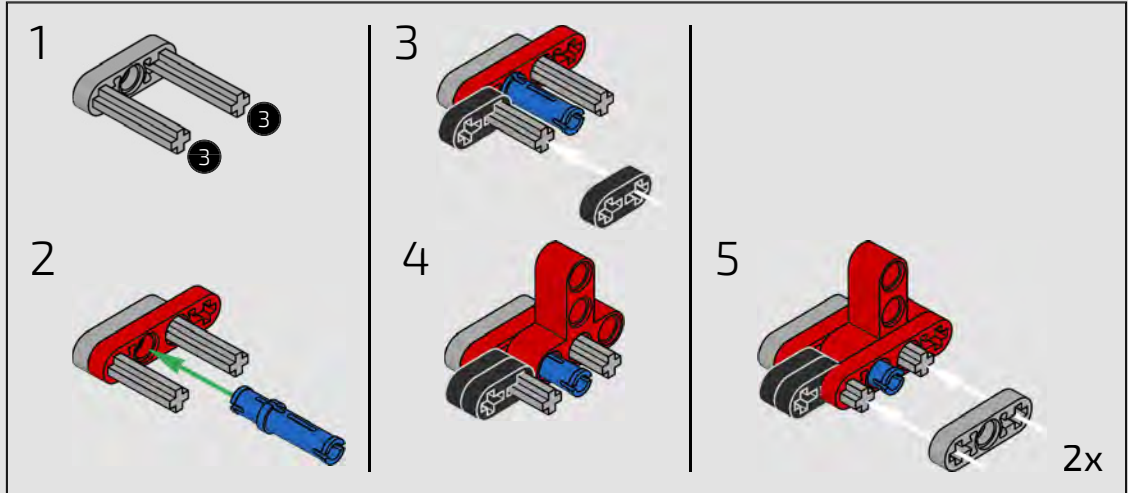

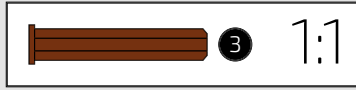
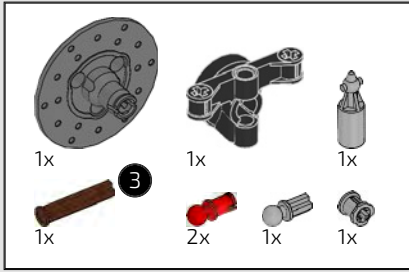

22

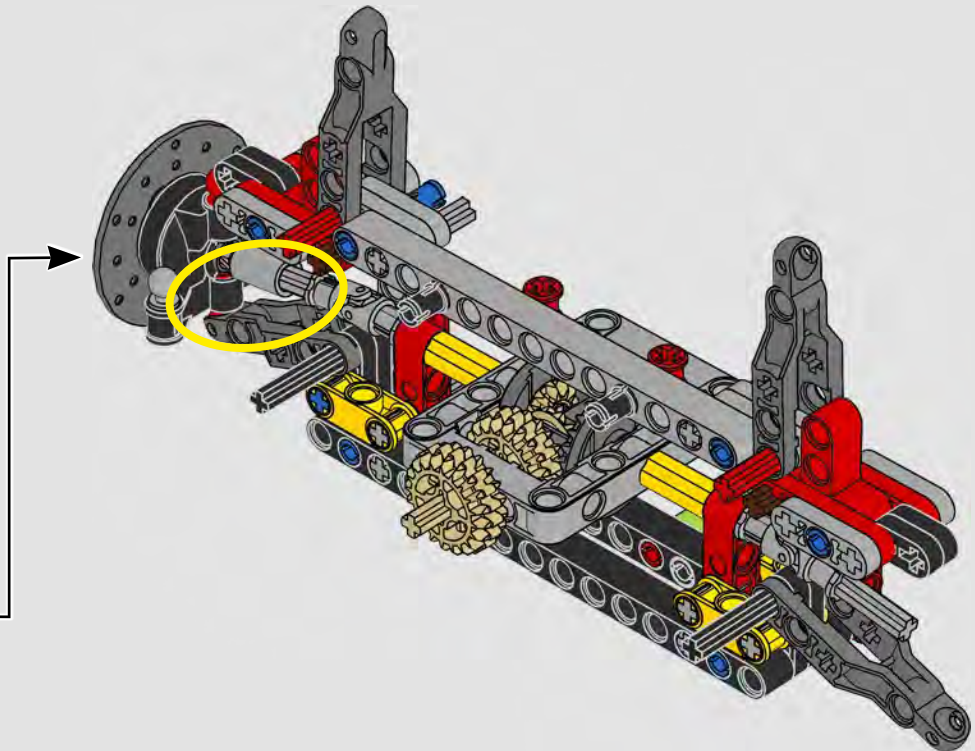
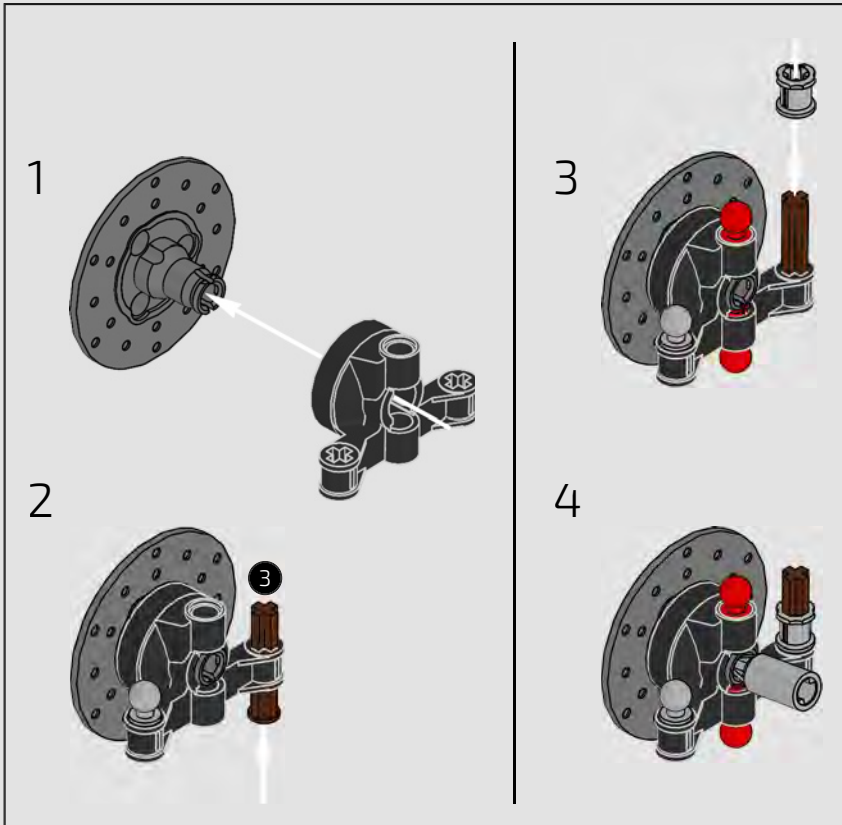
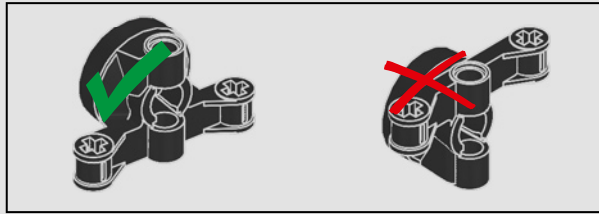

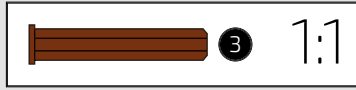
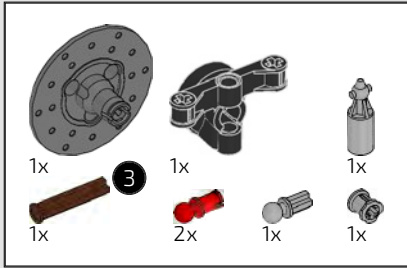

23

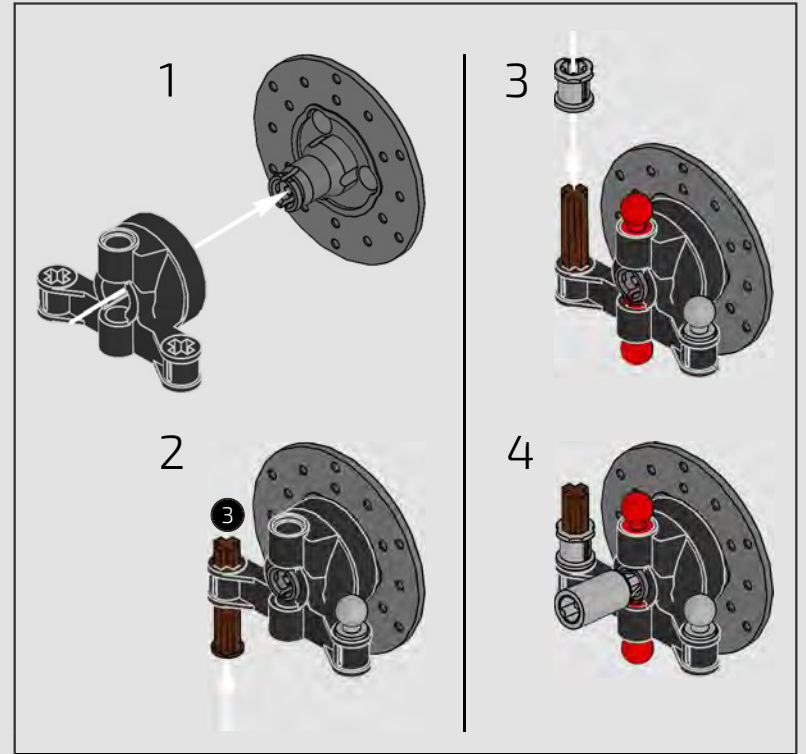
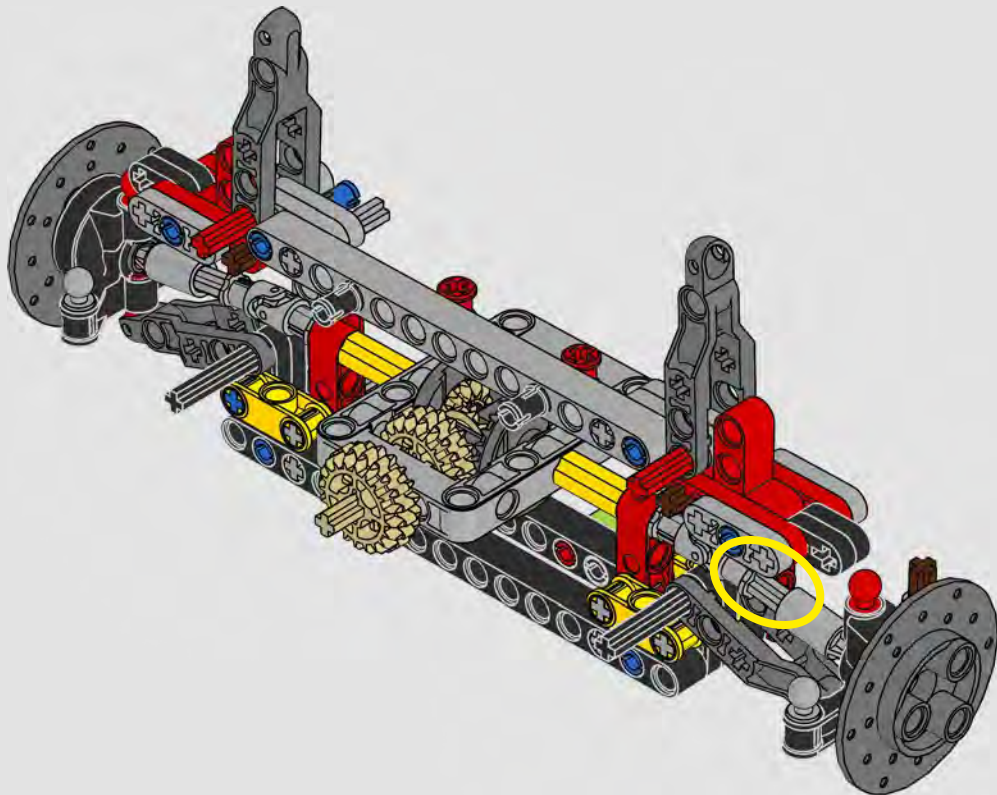
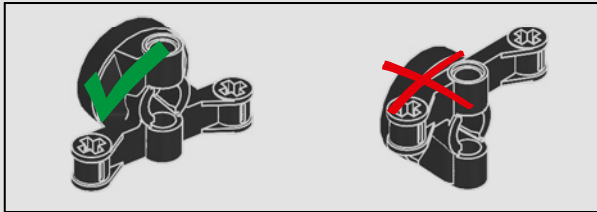

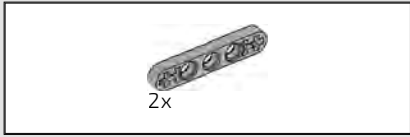

24

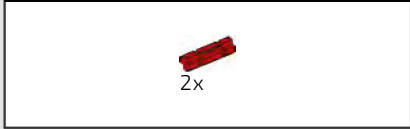
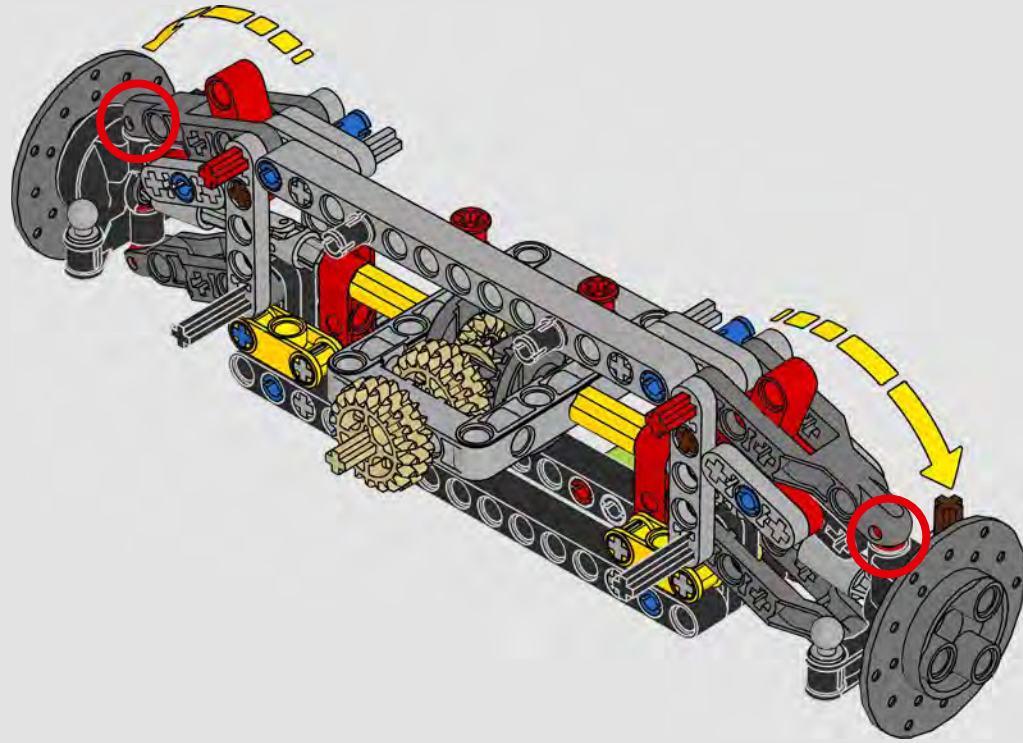

25

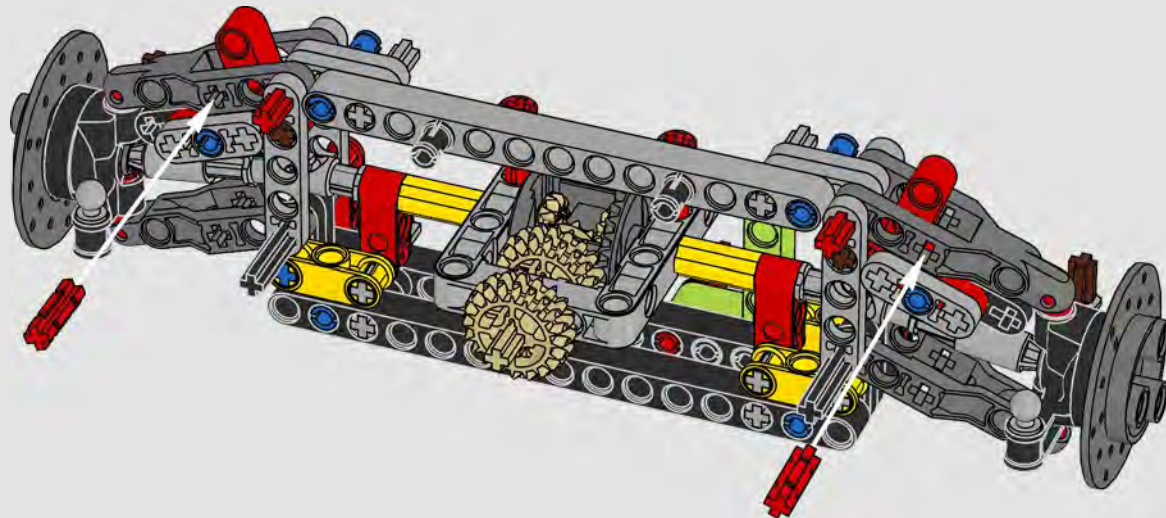

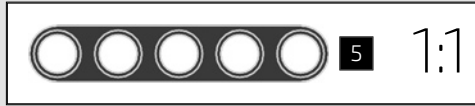
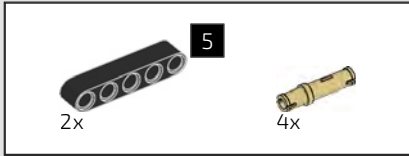

26

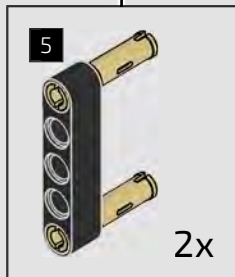
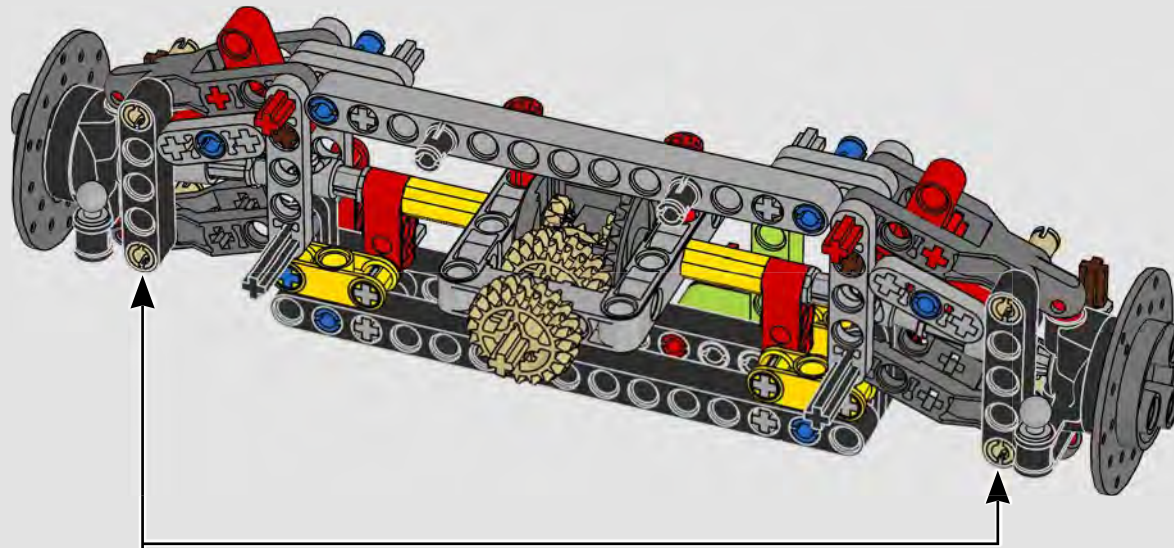



27

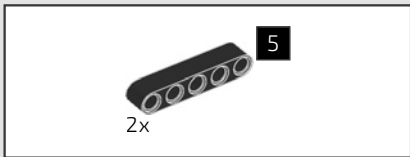
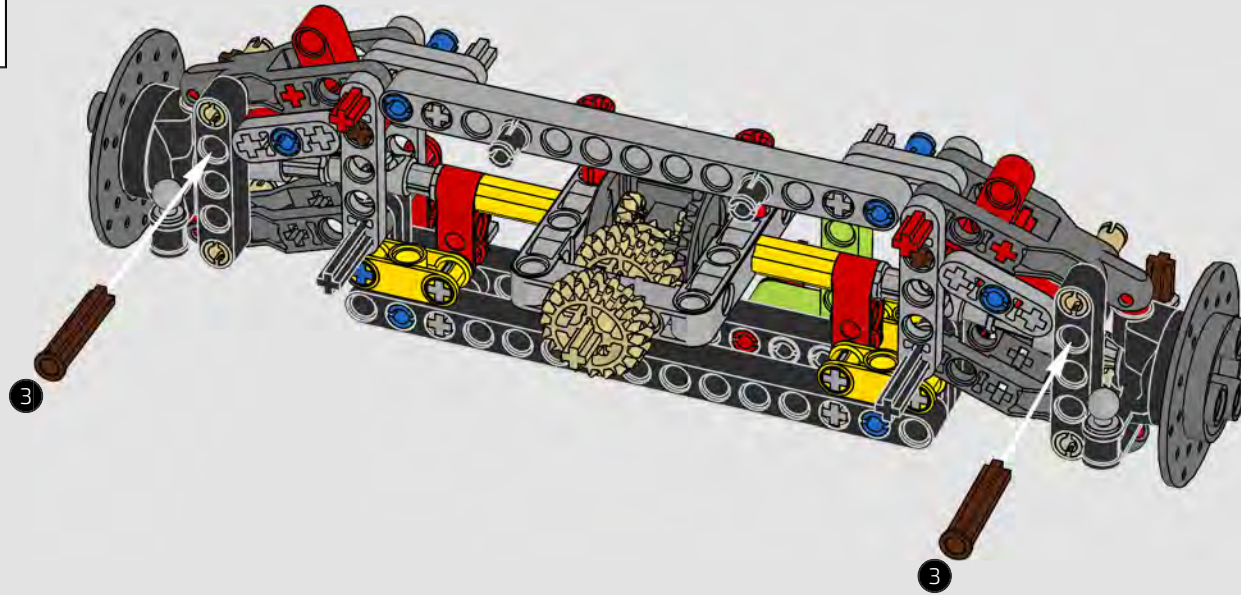

28

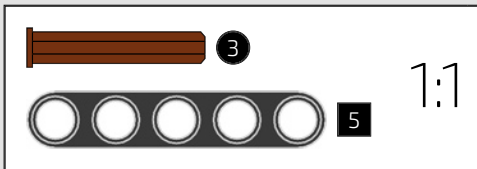
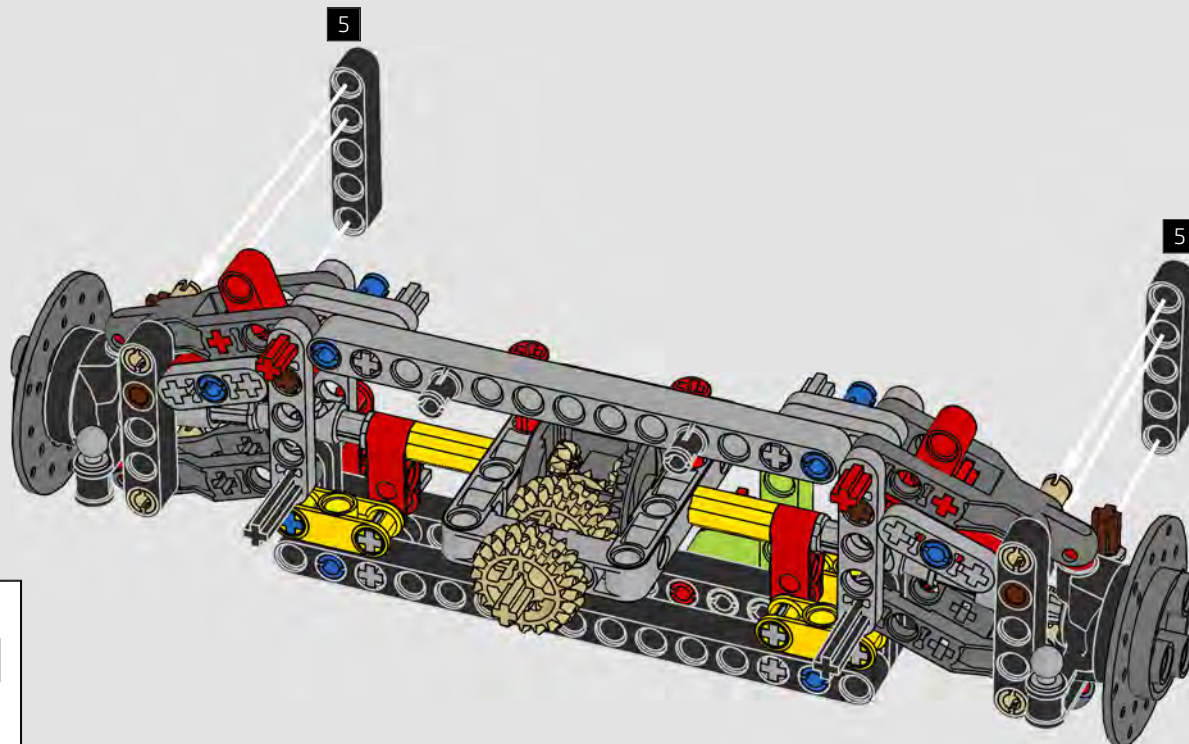

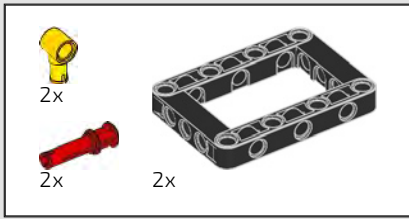

29

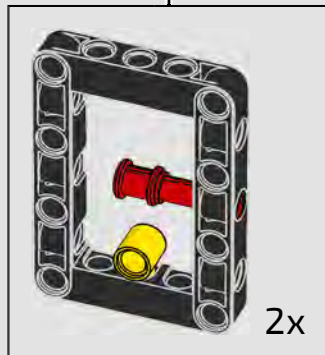
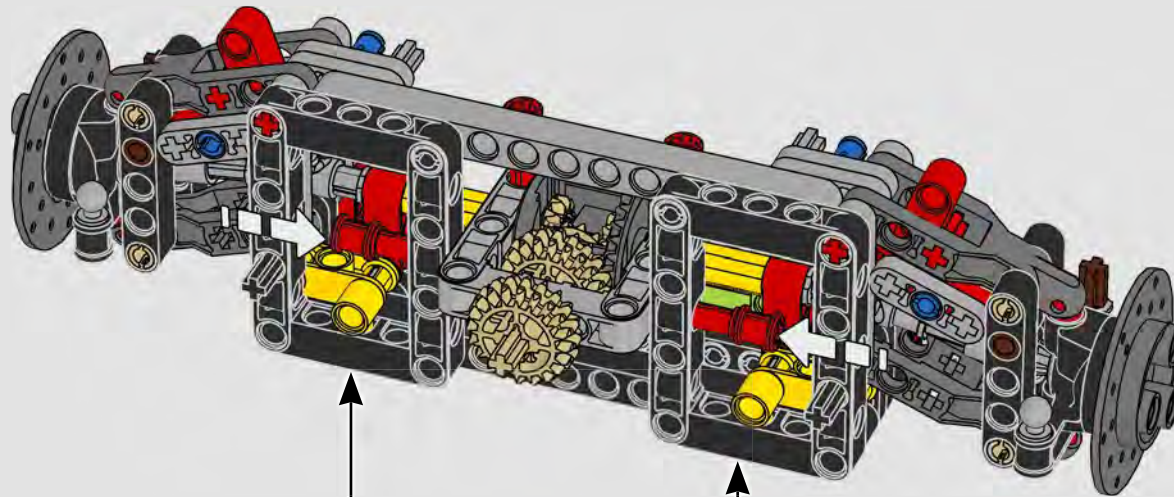

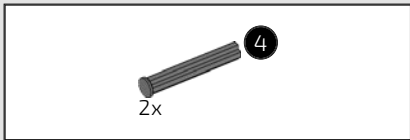

30

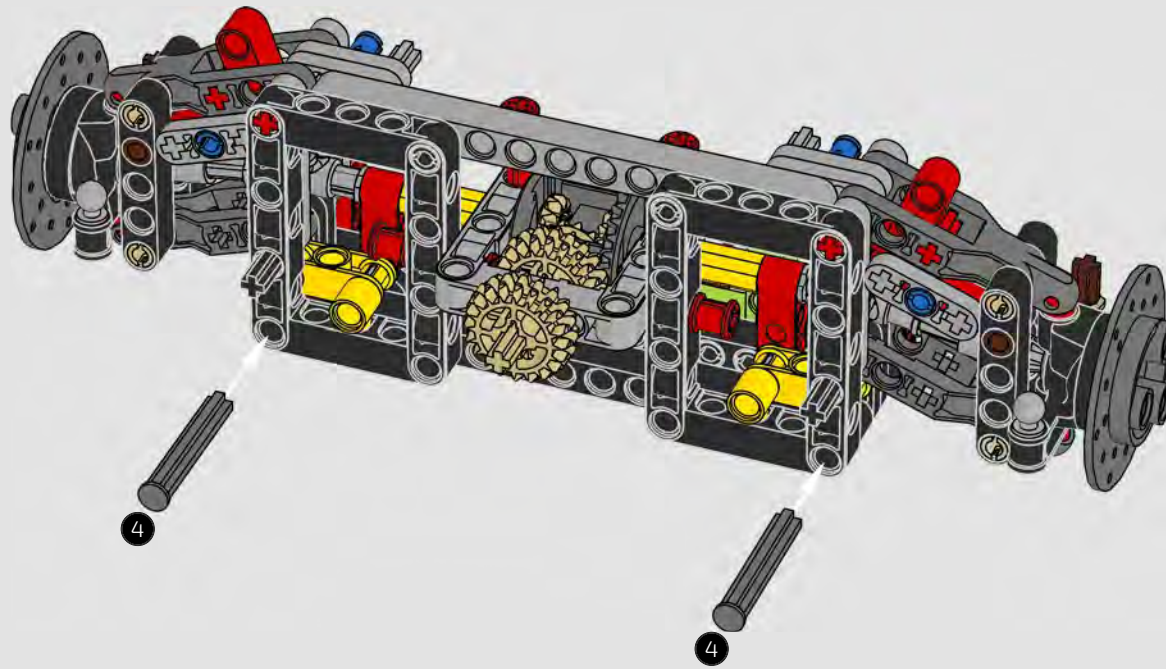
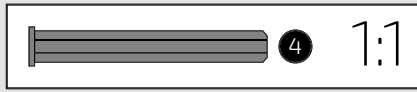

31

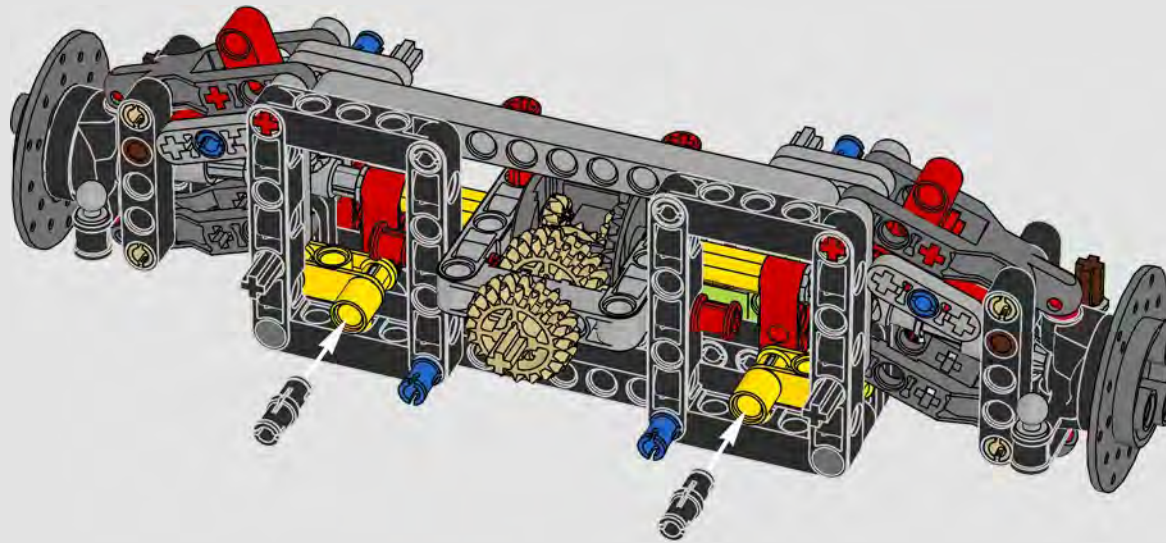

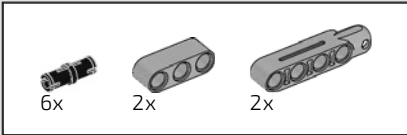

32

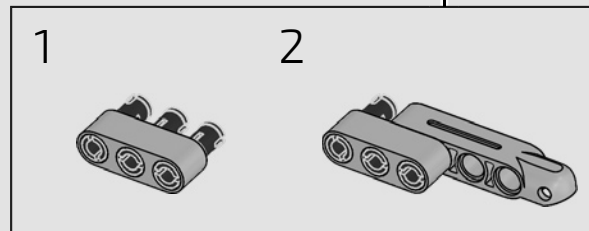
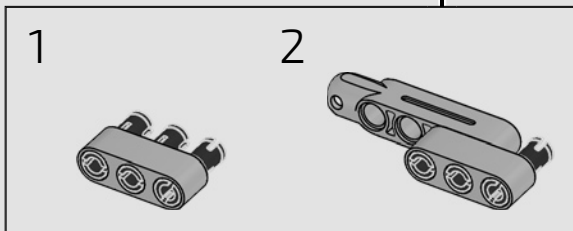
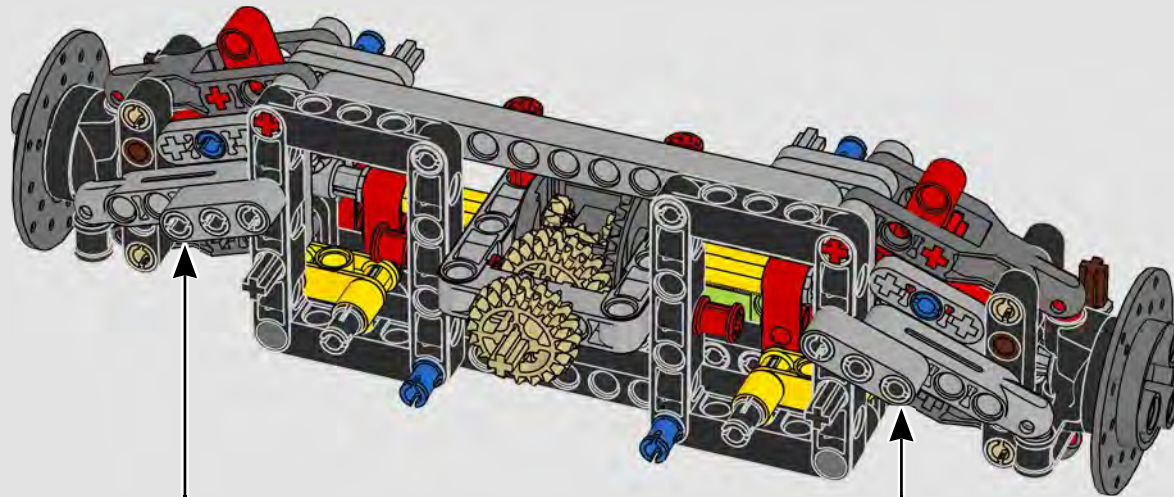

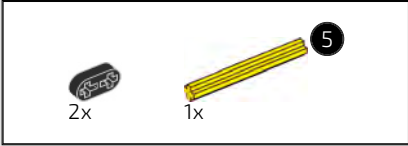
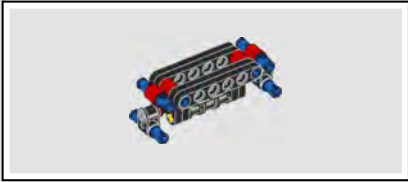

33

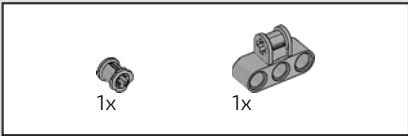

34

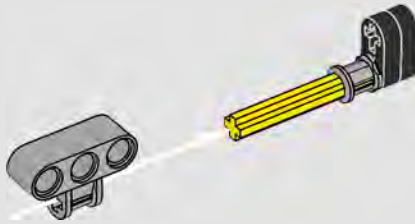

35

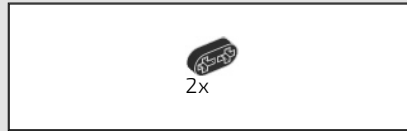
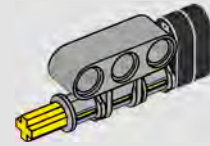

36

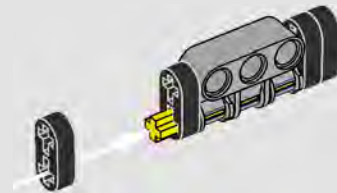

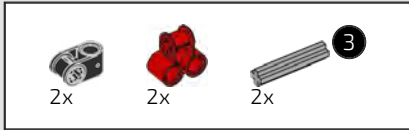

37

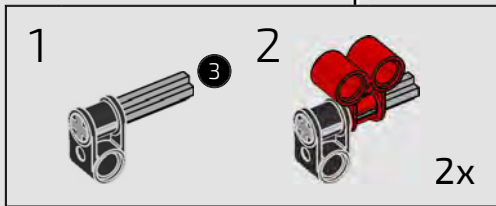
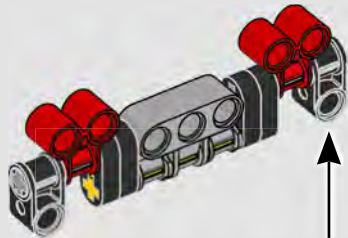

38

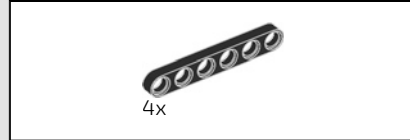
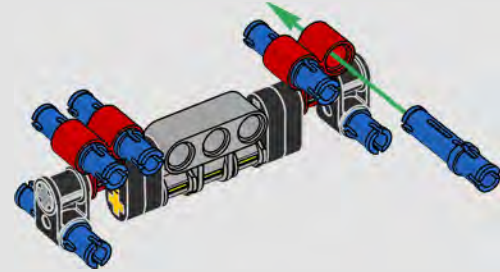

39

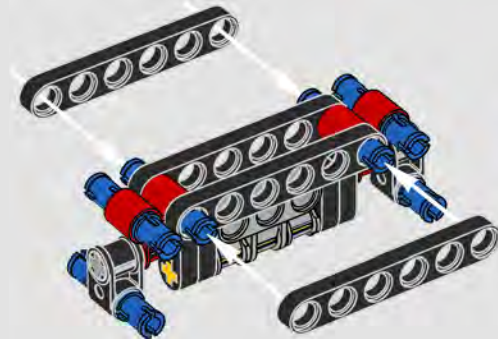

40

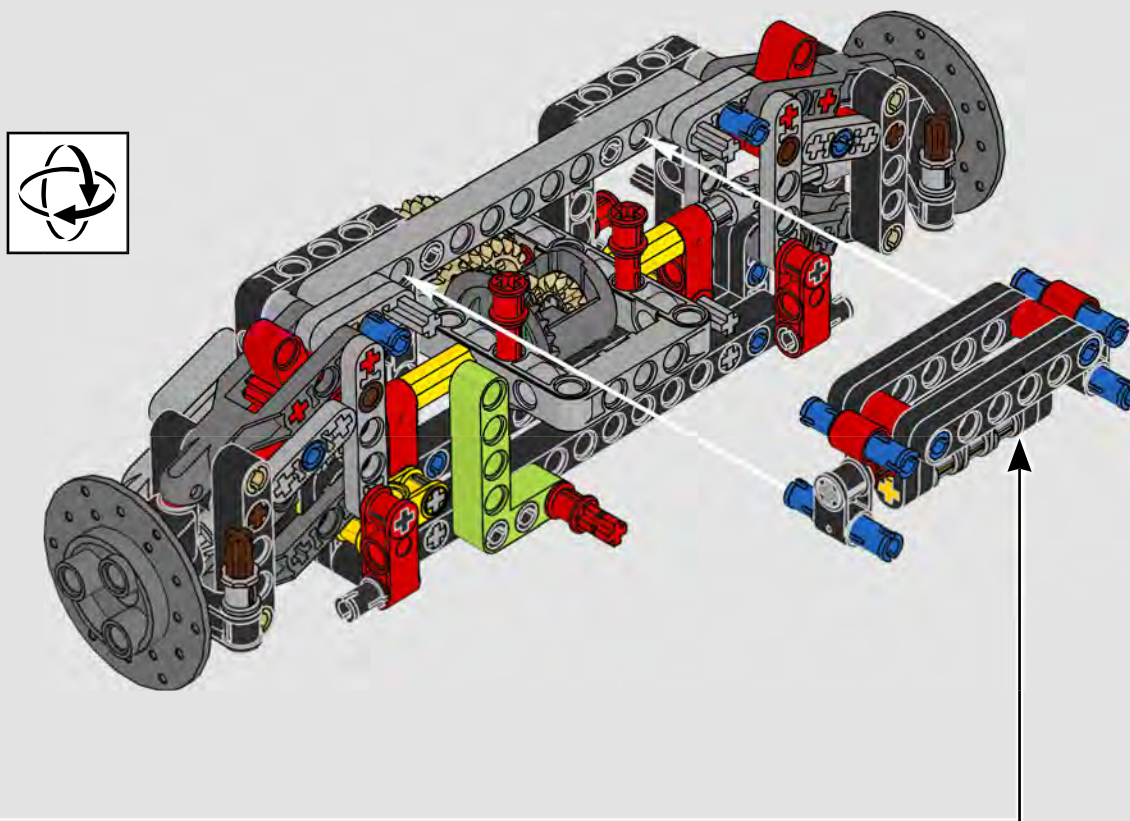



41

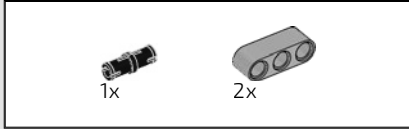
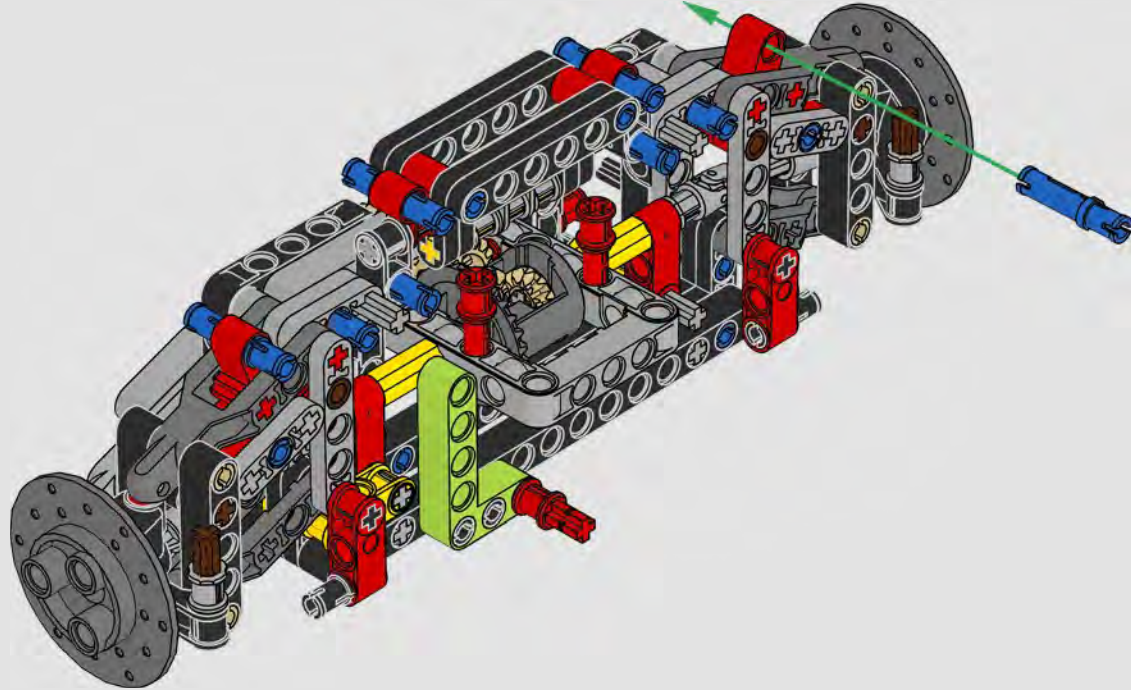

42

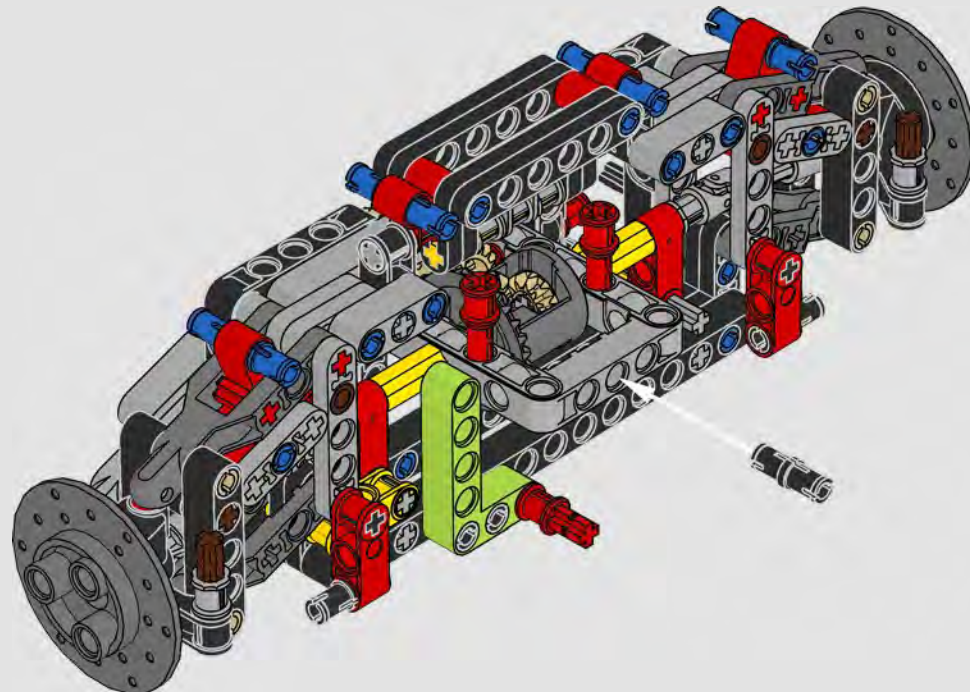



43

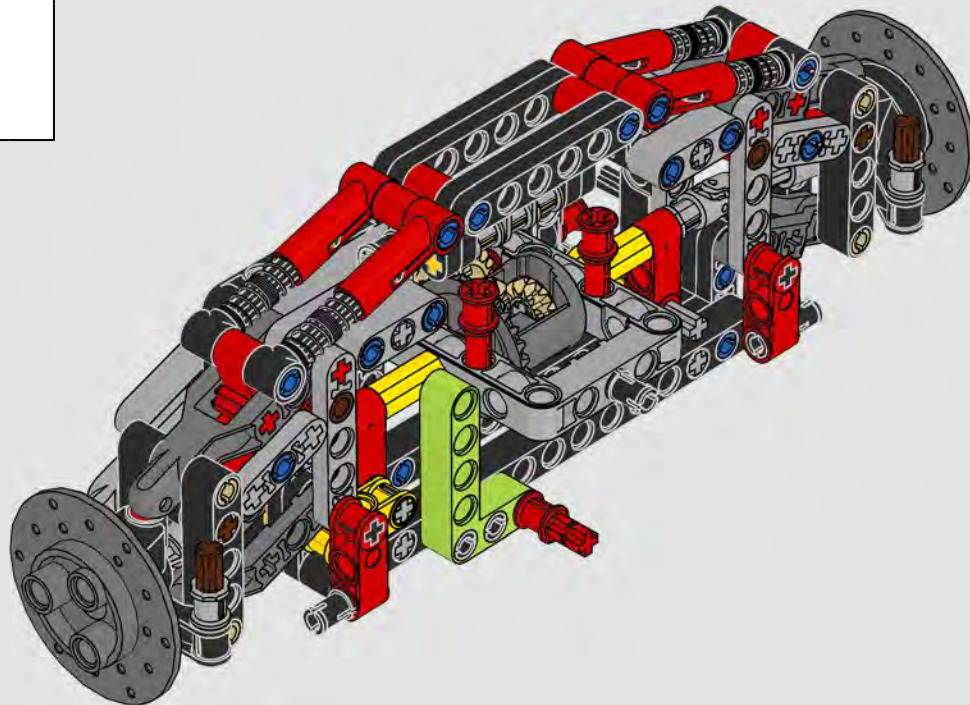

44

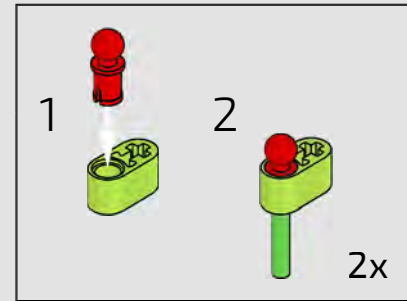
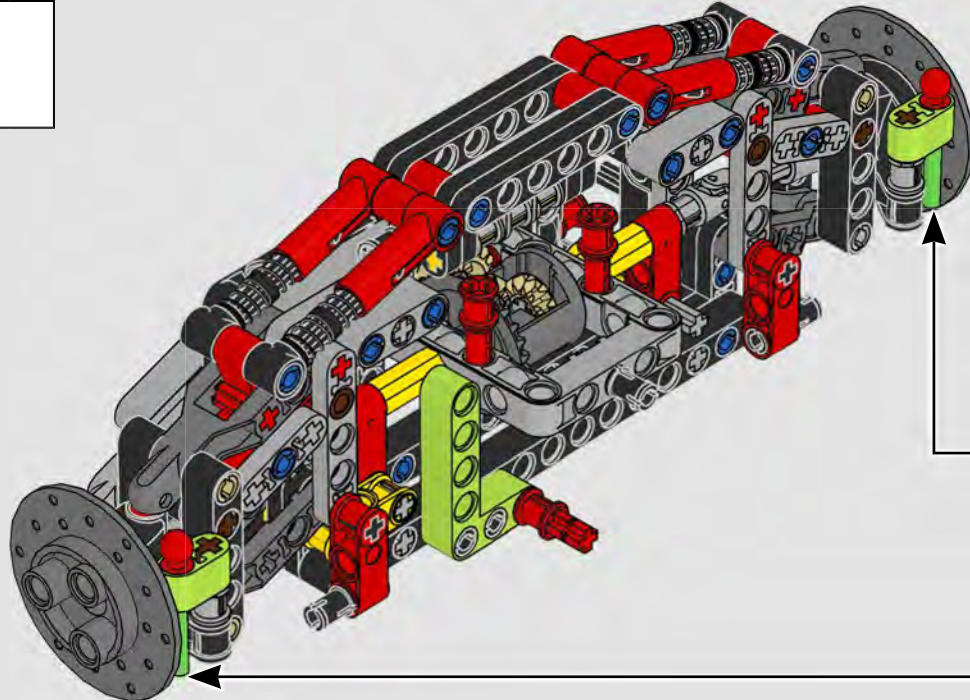

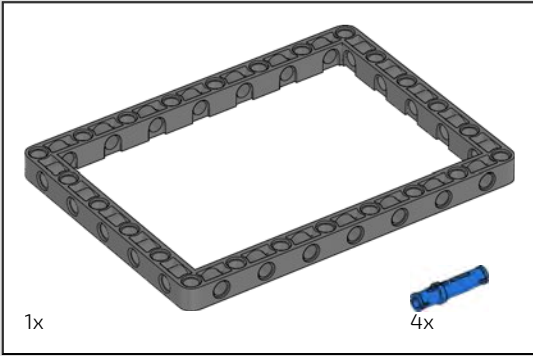
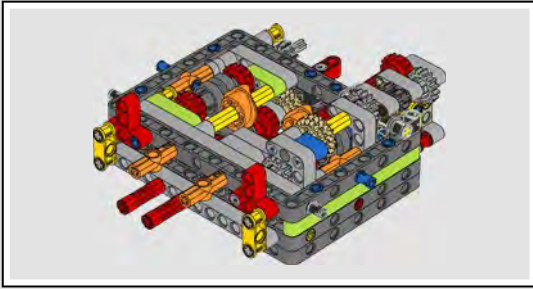

45

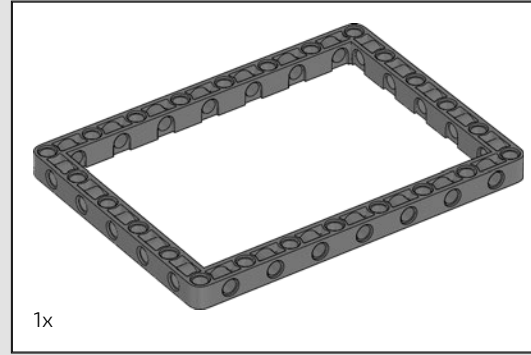
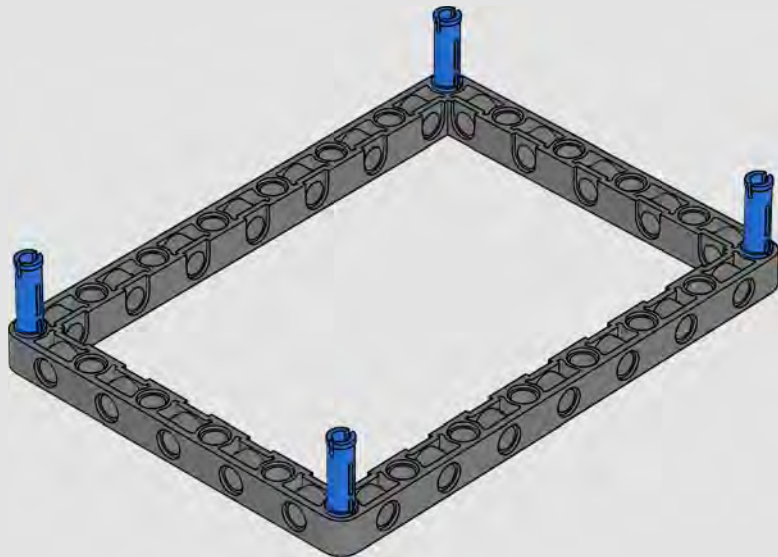

46

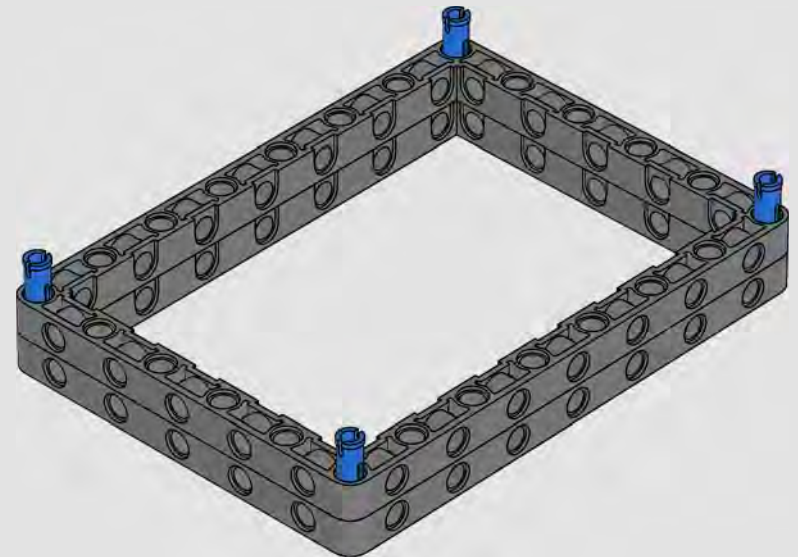



47

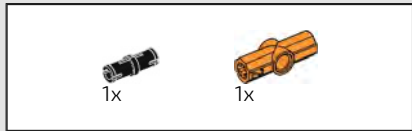
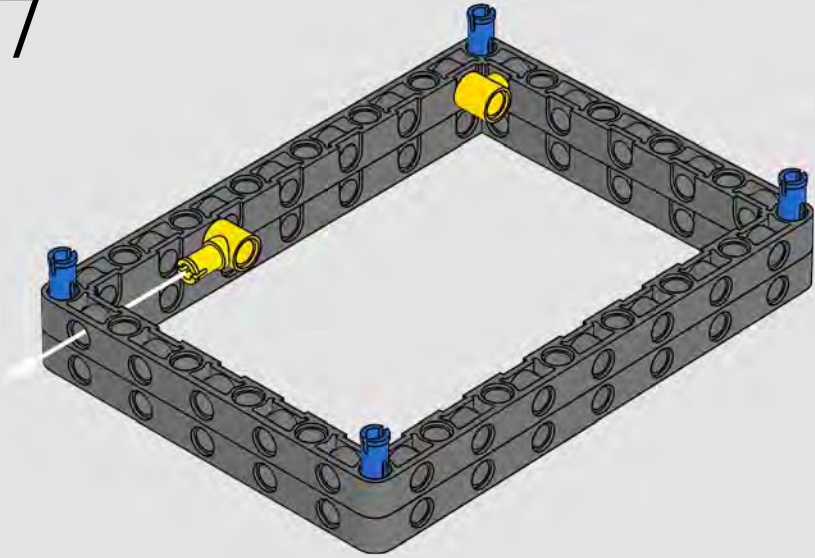

48

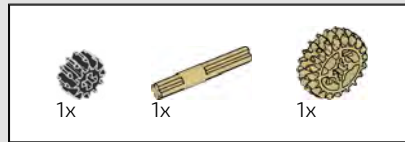
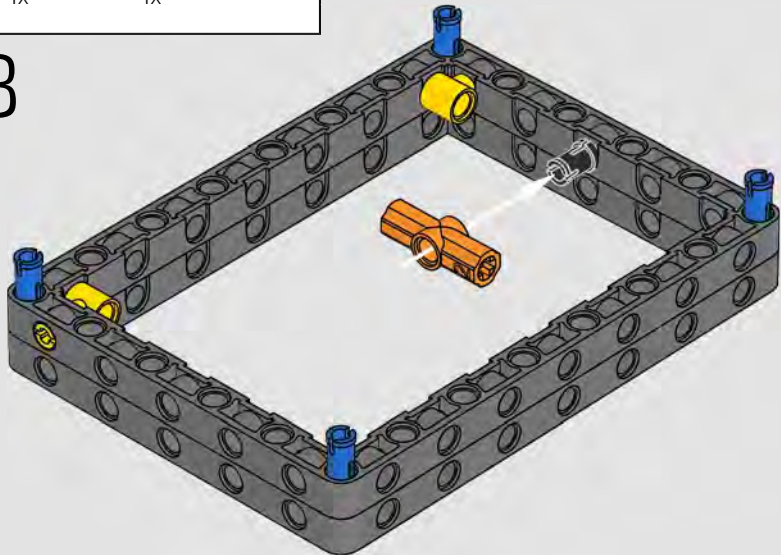

49

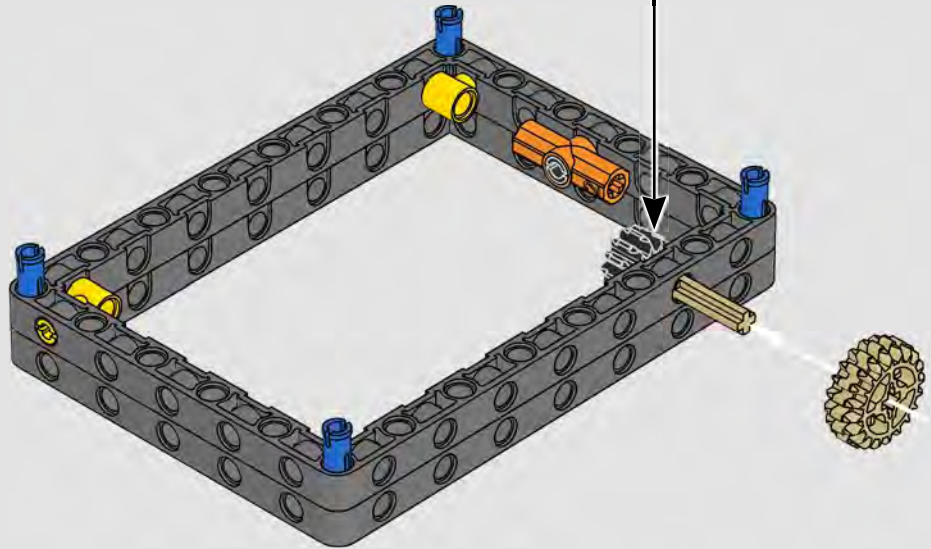
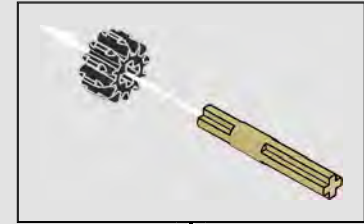

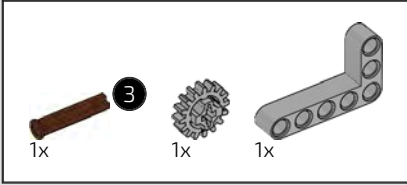
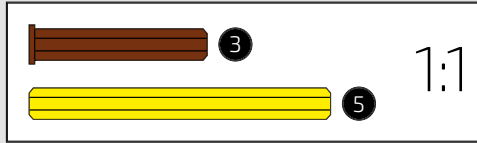
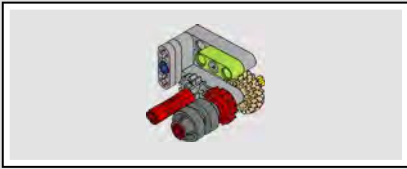

50

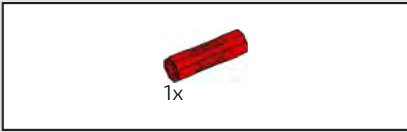
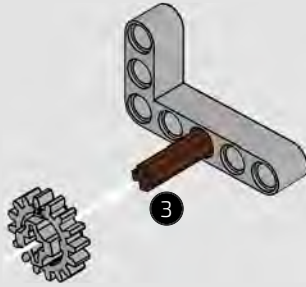

51

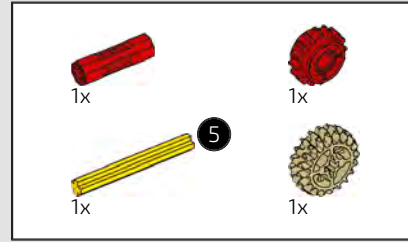
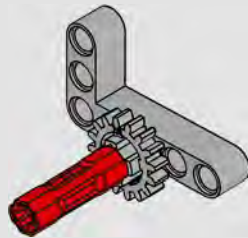

52

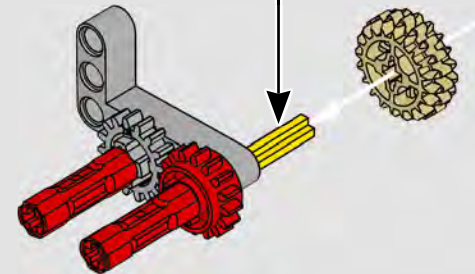
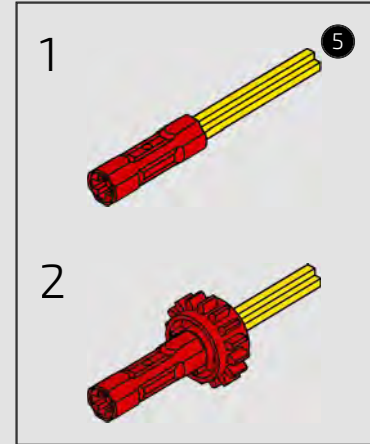

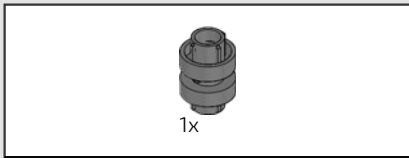

53

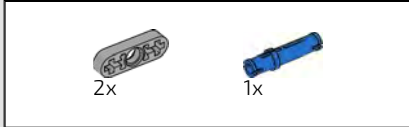
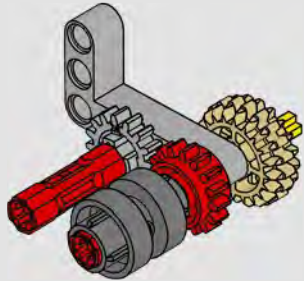

54

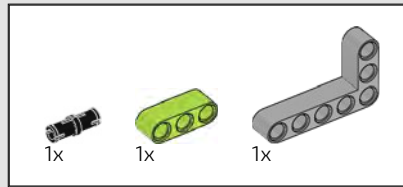
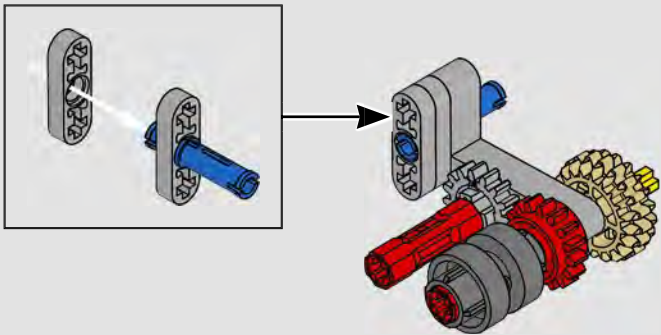

55

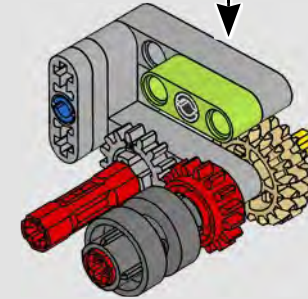
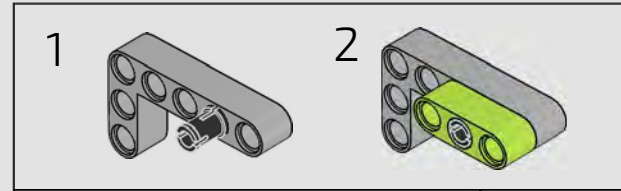

56

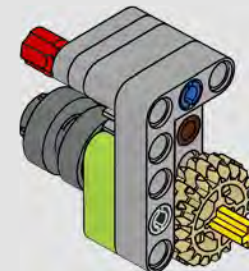

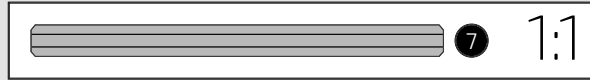
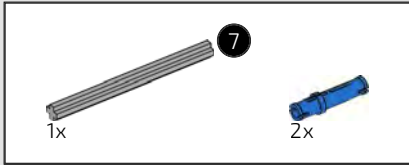

59

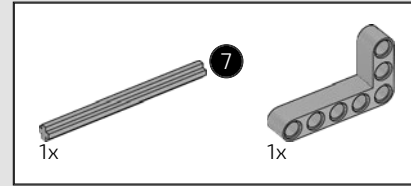
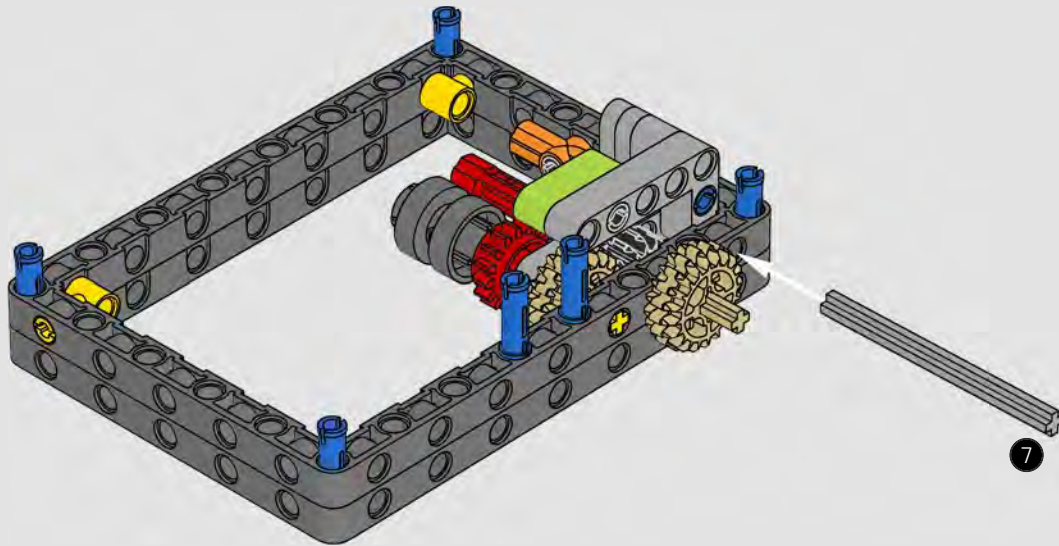

60

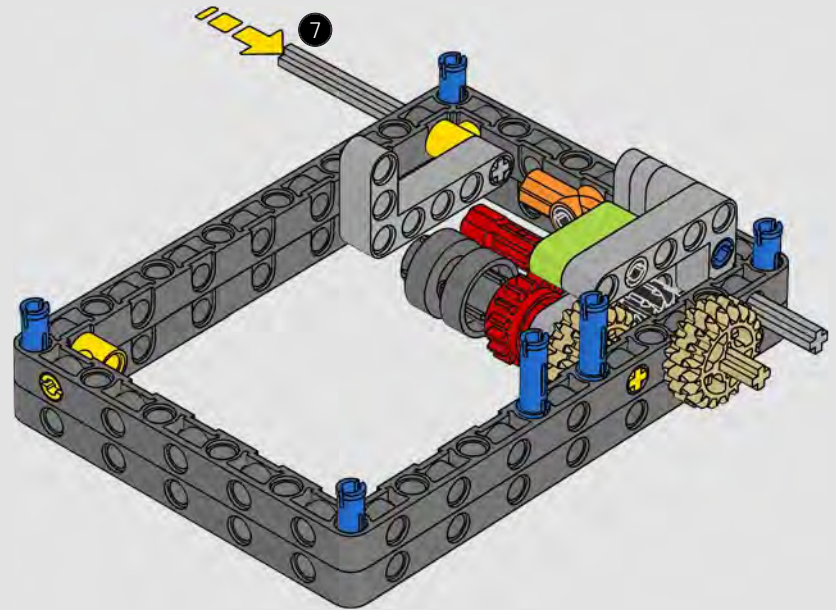

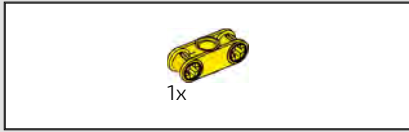

61

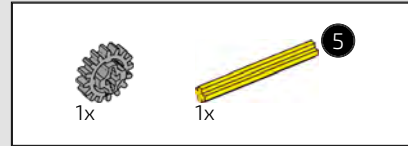
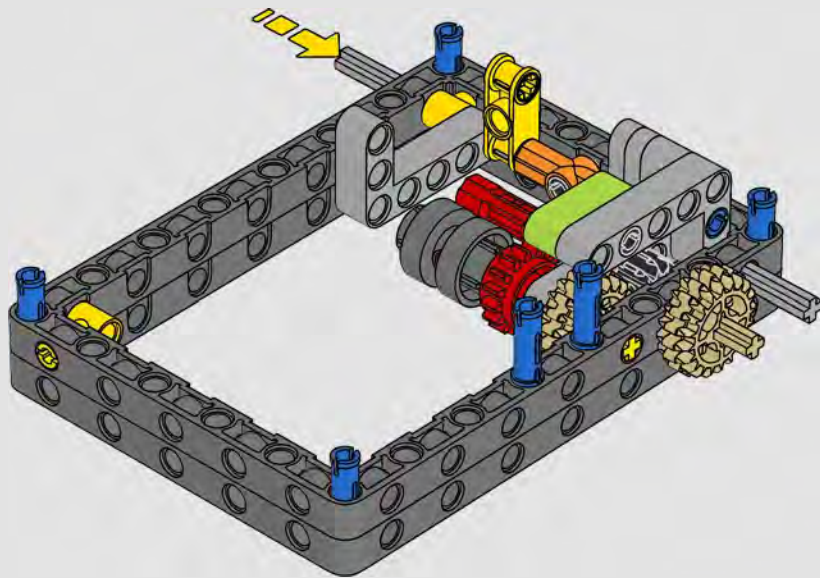

62

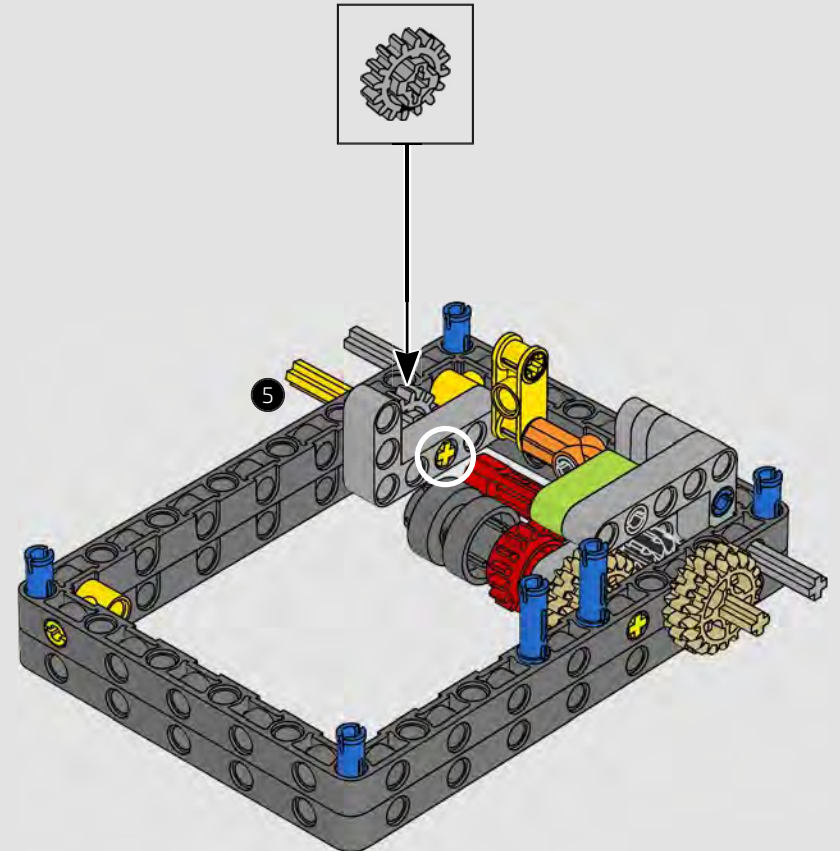
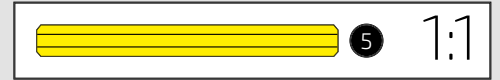

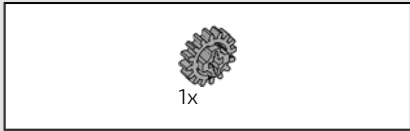

63

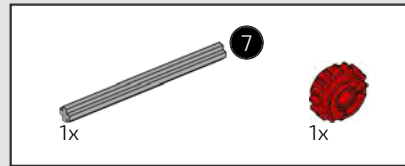
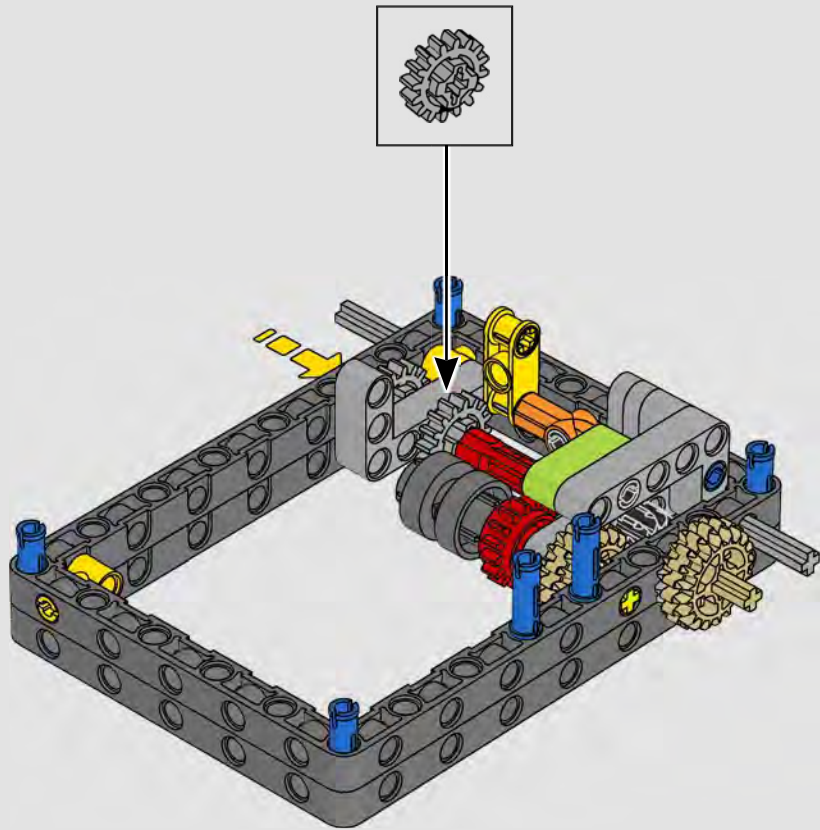

64

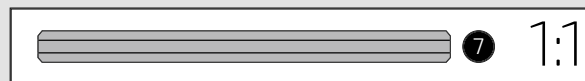
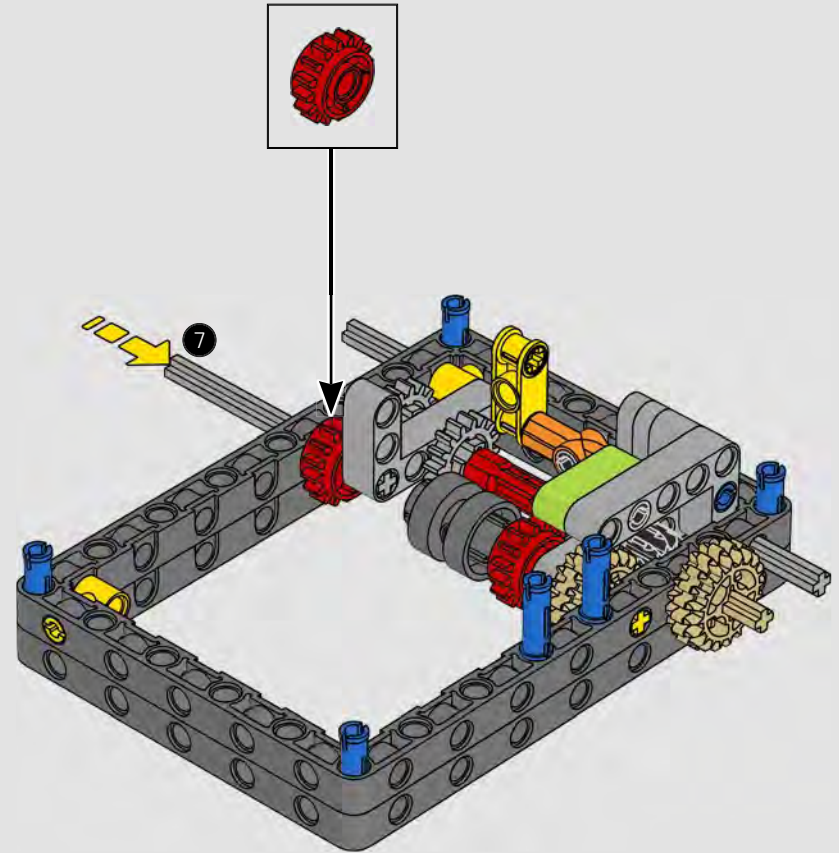



65

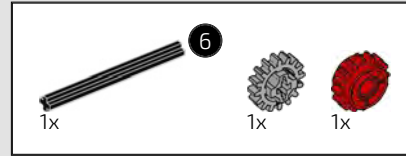
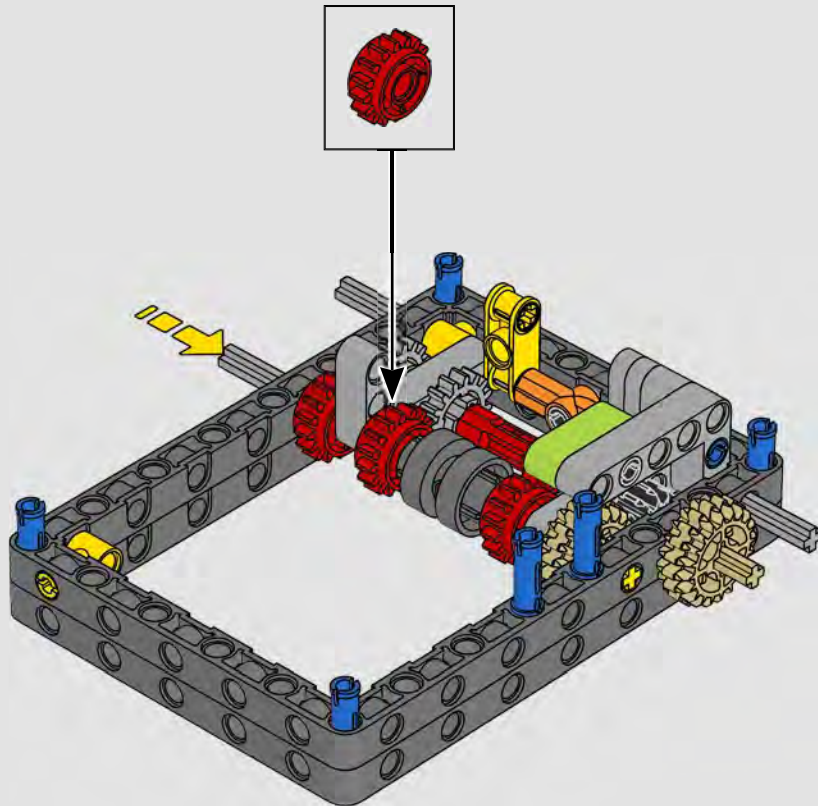

66

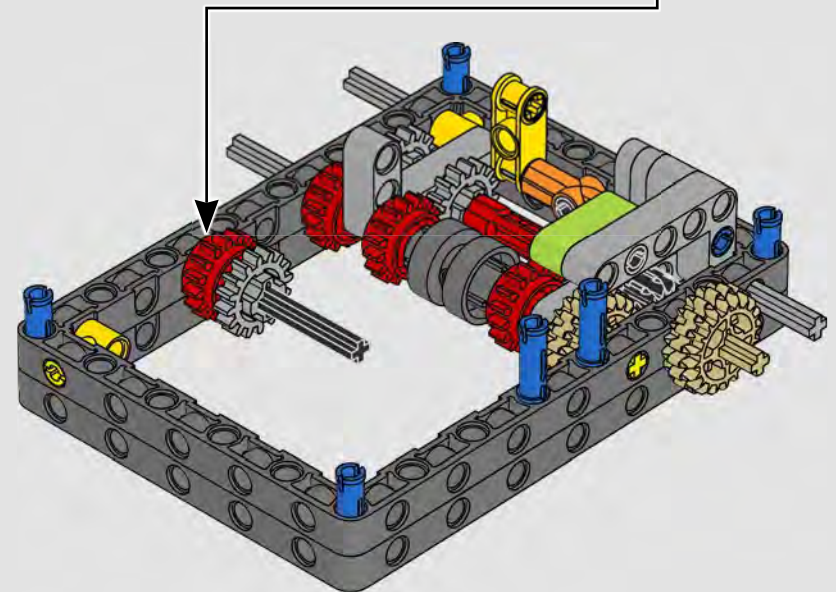
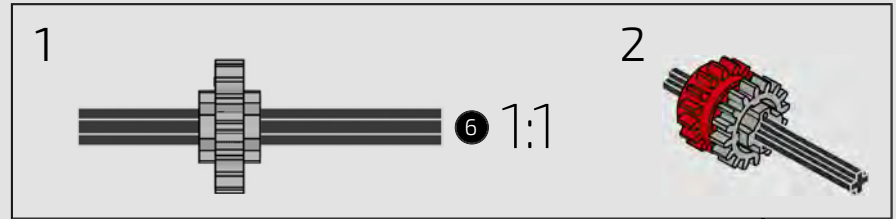

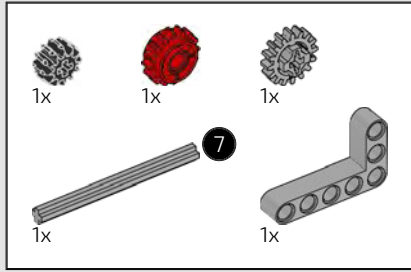

67

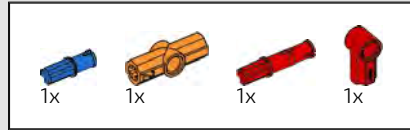
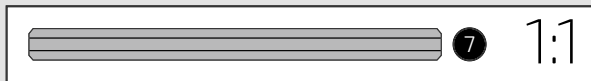
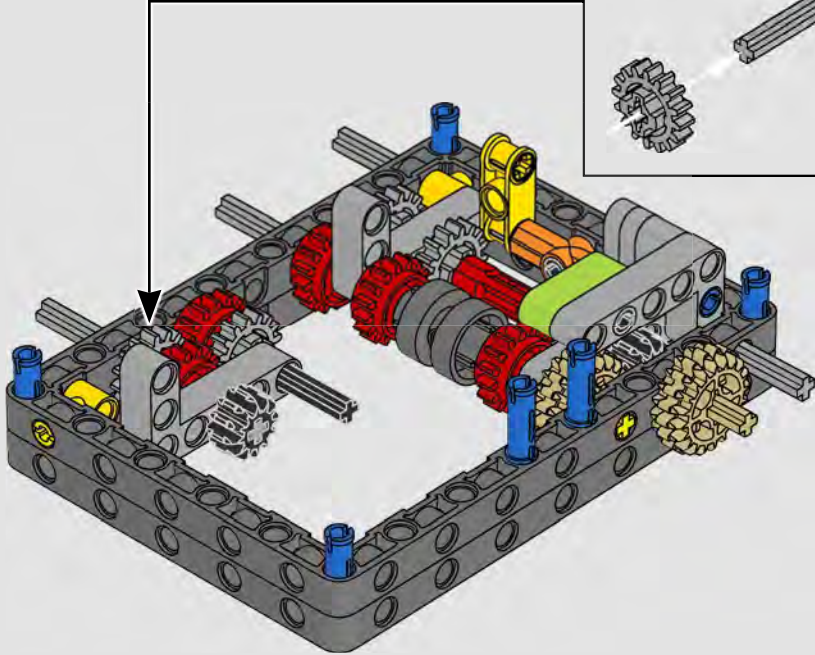
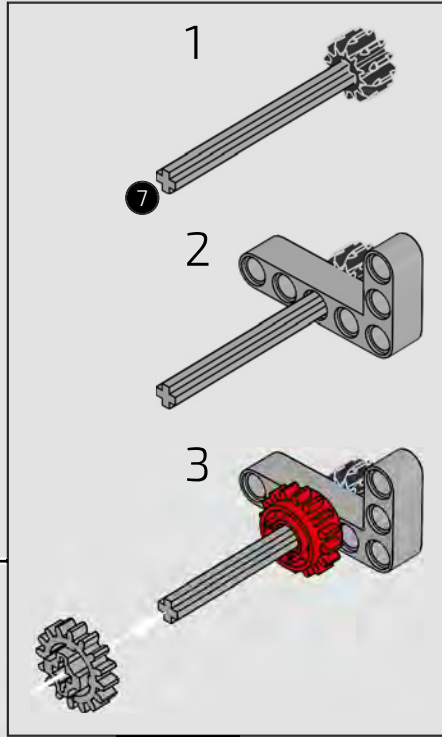
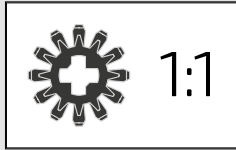

68

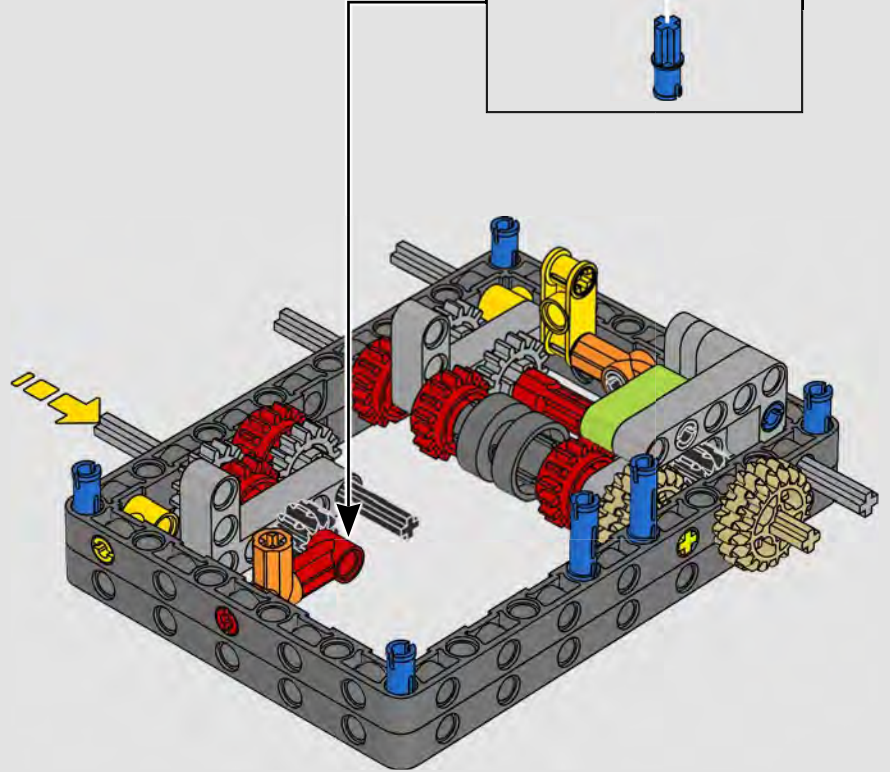
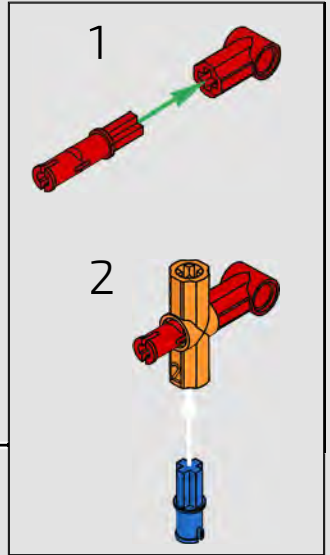

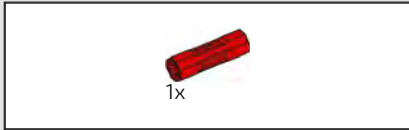

69

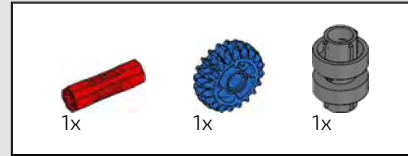
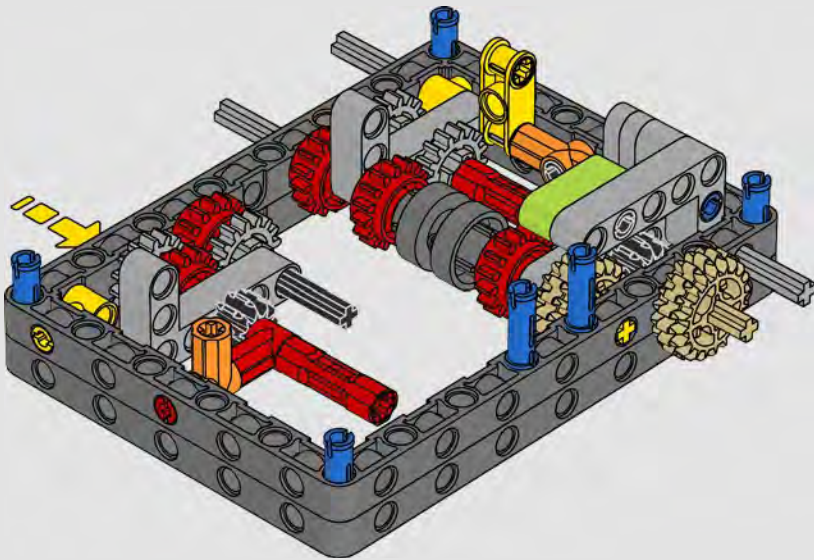

70

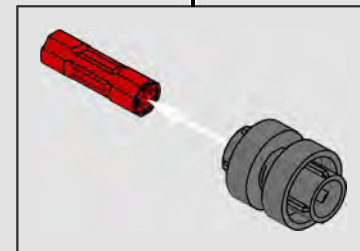
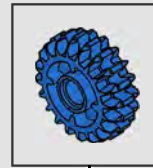
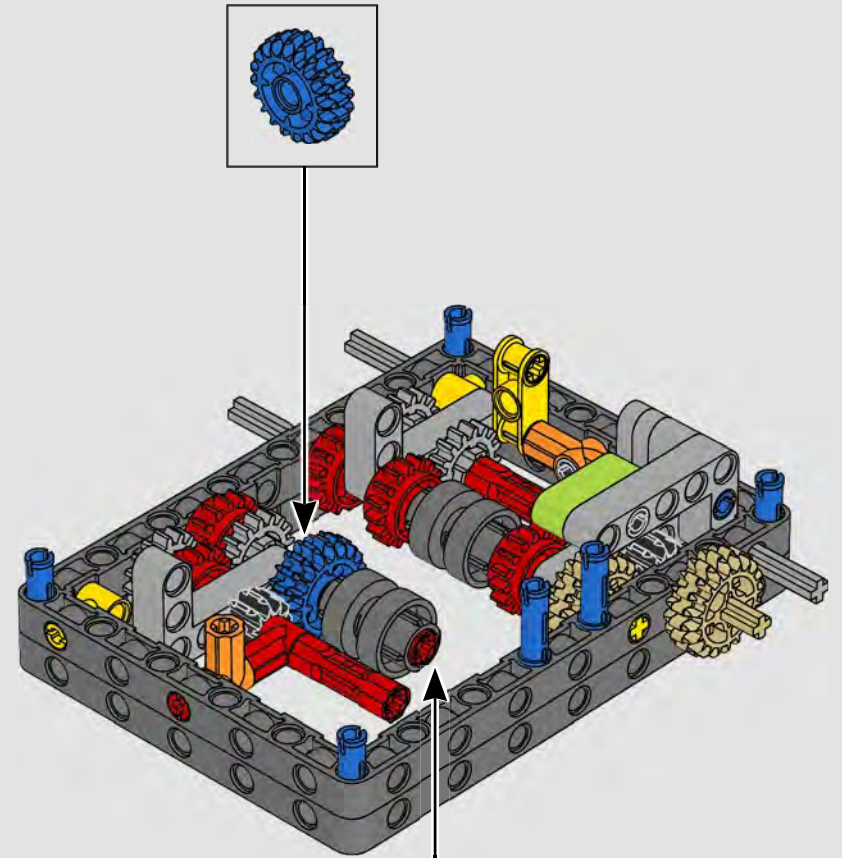

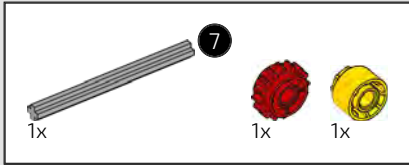

71

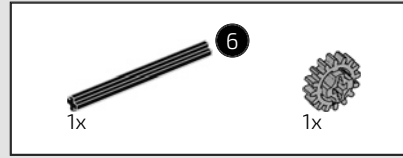
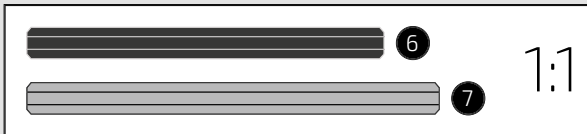
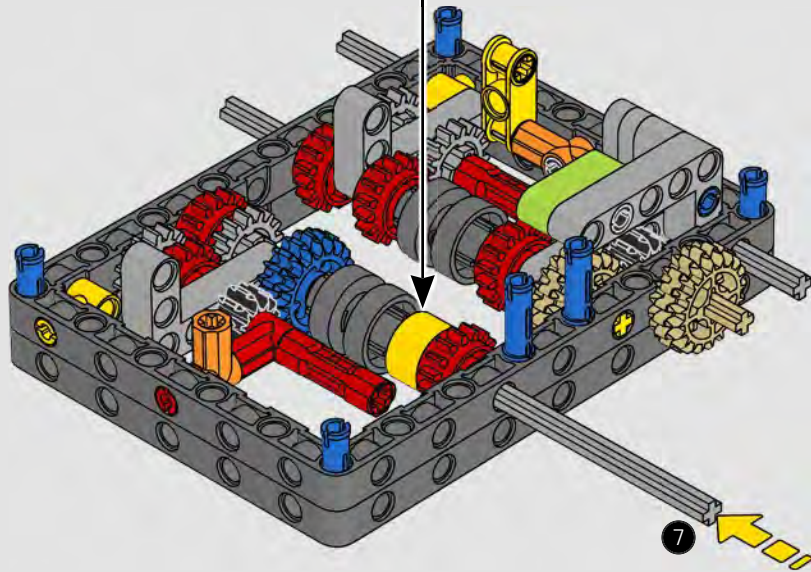
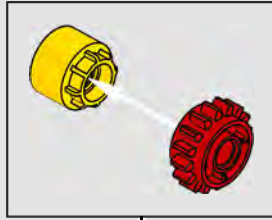

72

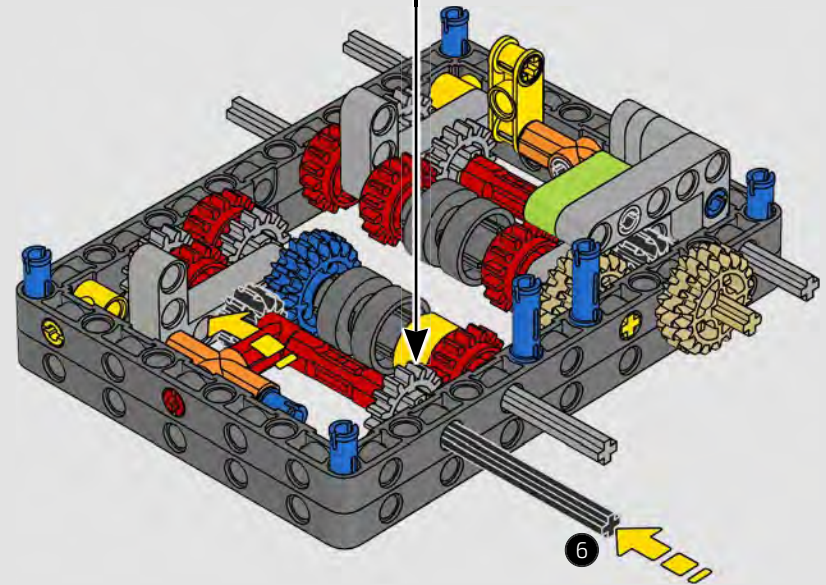
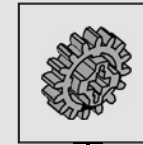

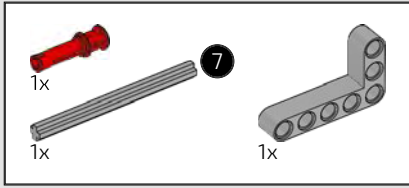

73

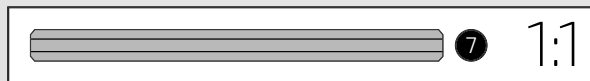
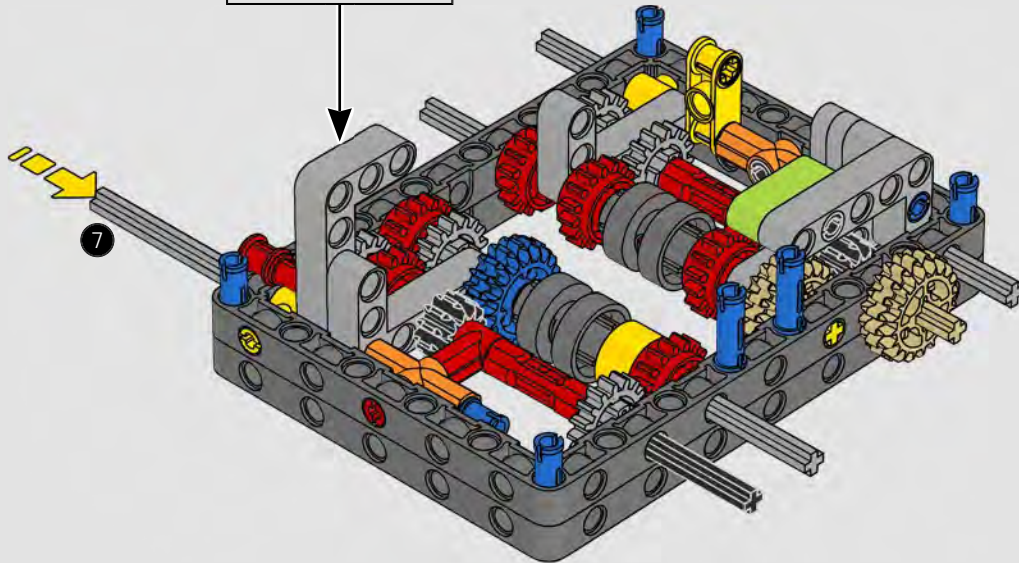
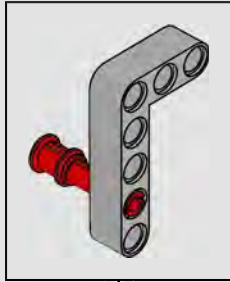

74

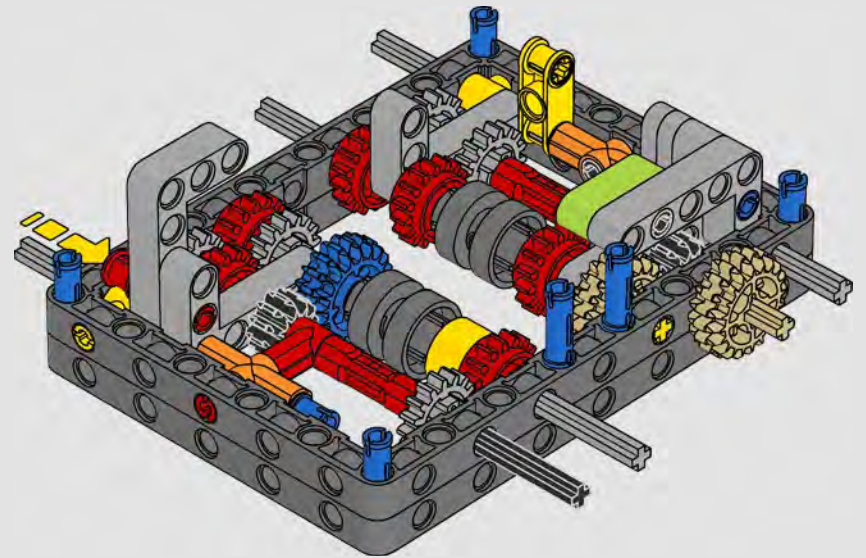

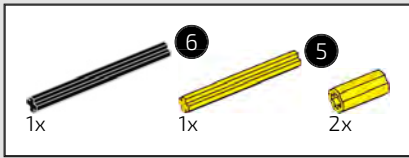

75

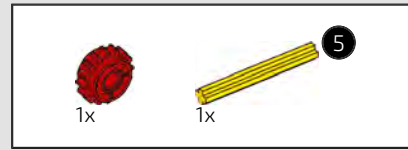
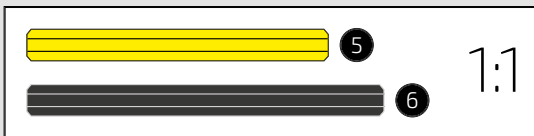
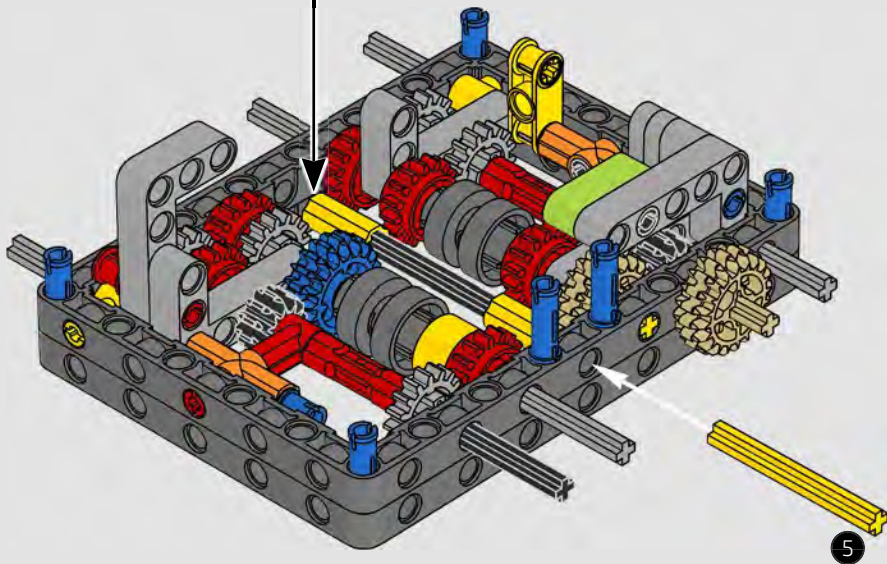
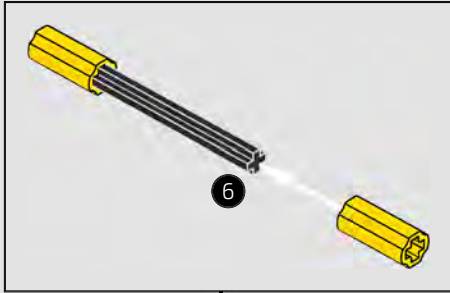

76

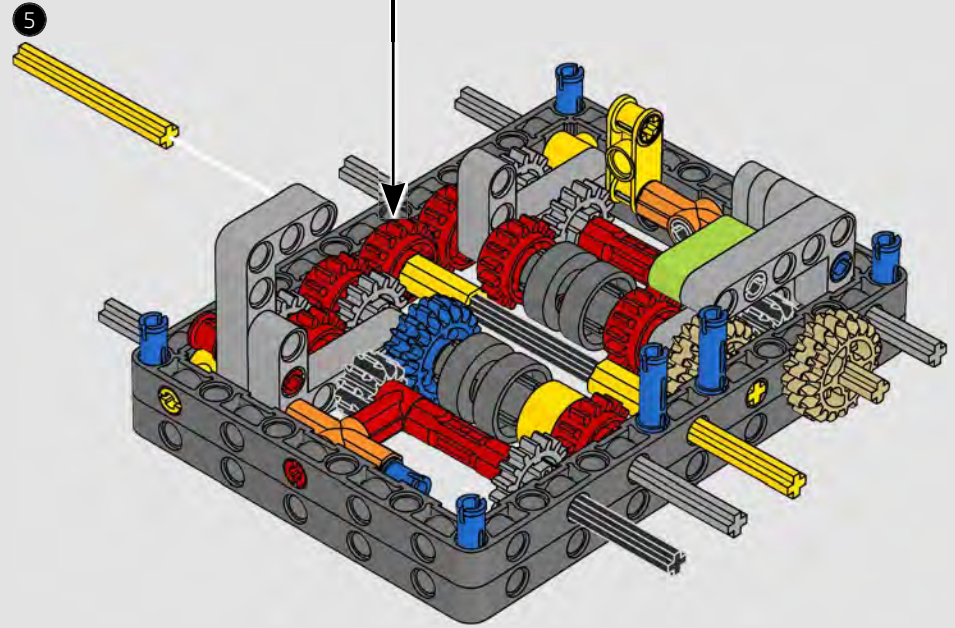

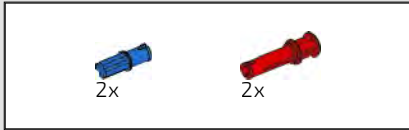

77

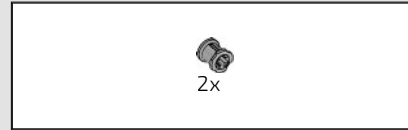
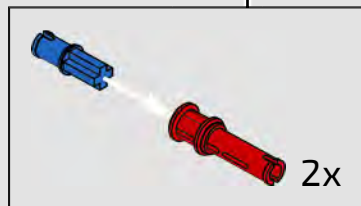
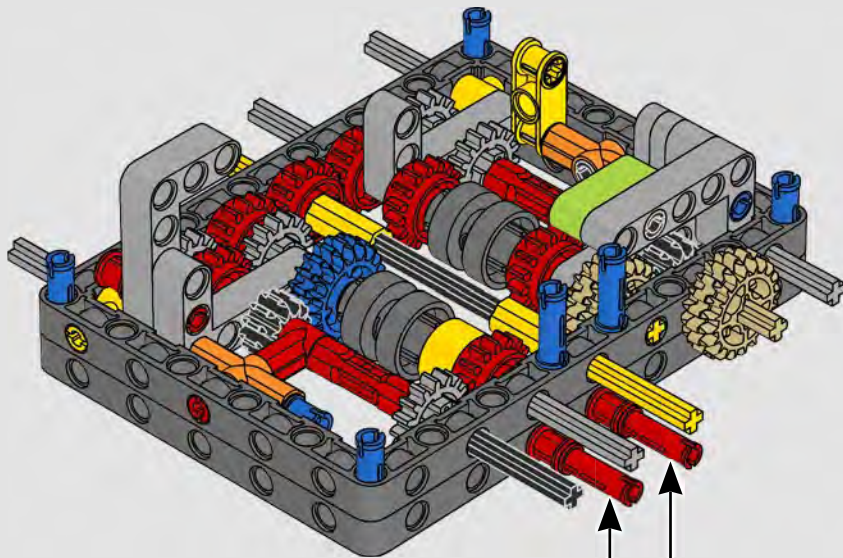

78

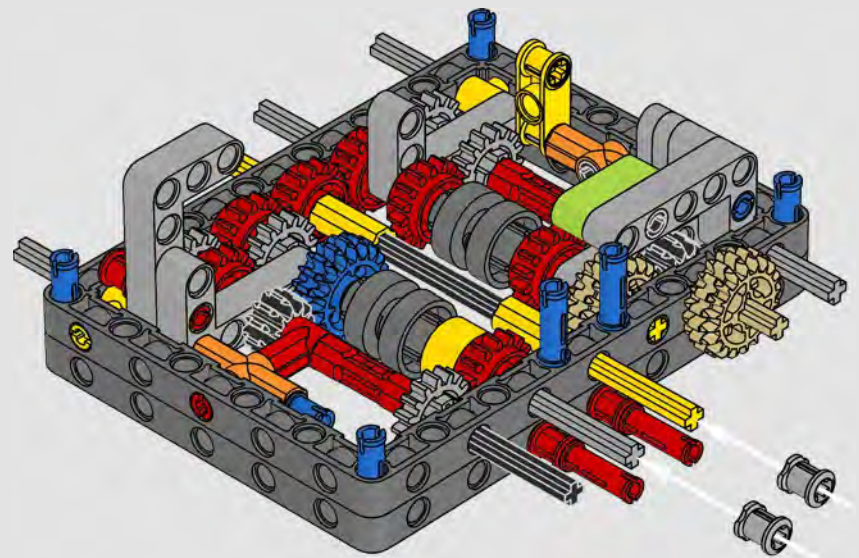

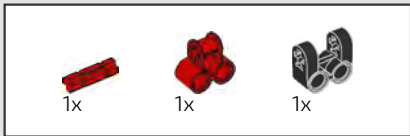

79

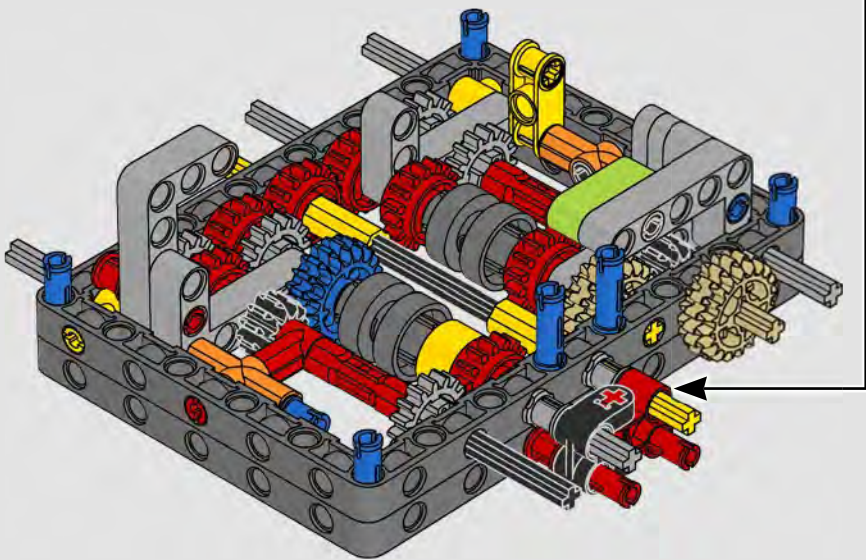
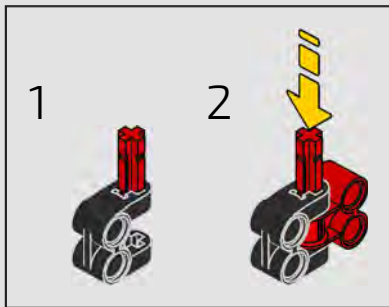

80

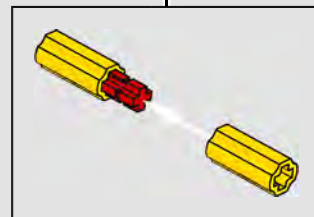
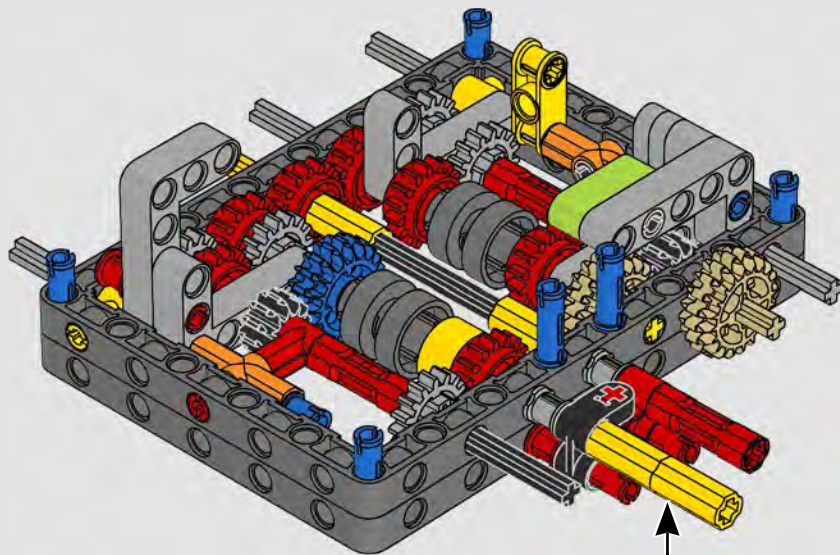

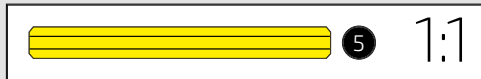
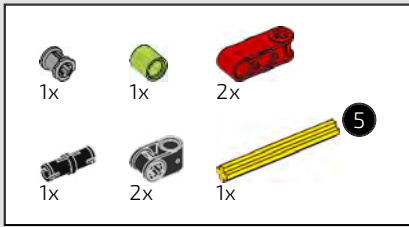

81

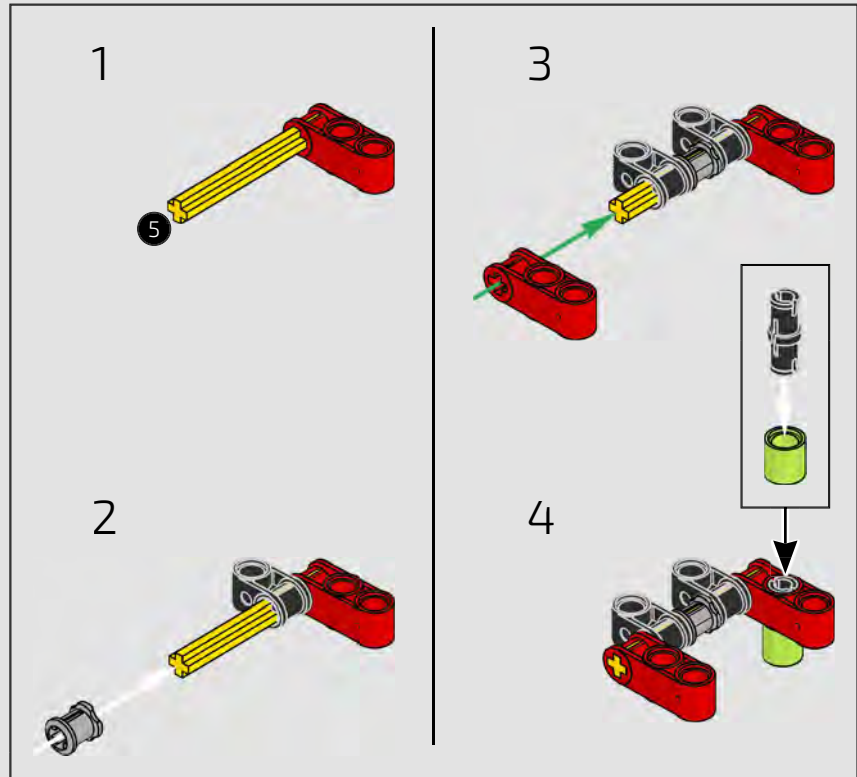
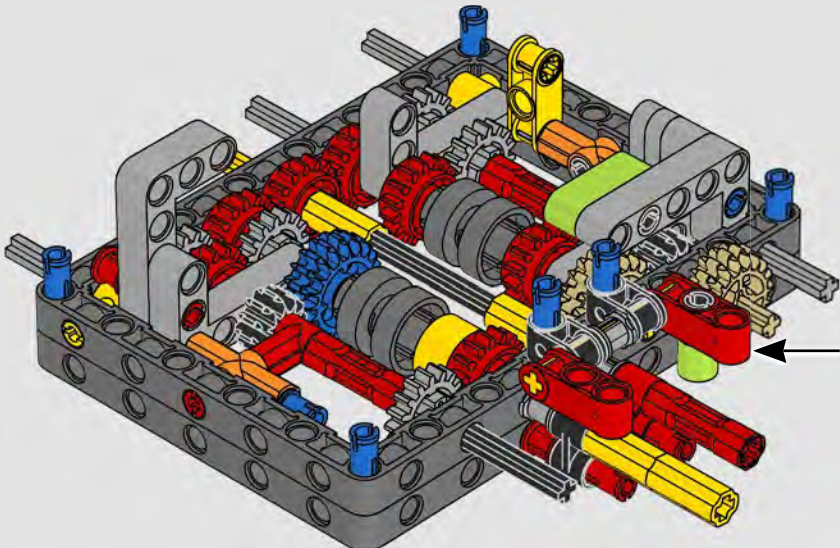

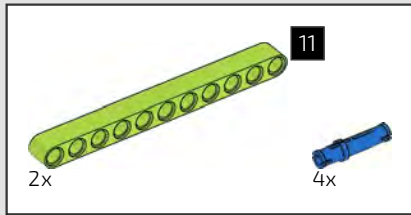

82

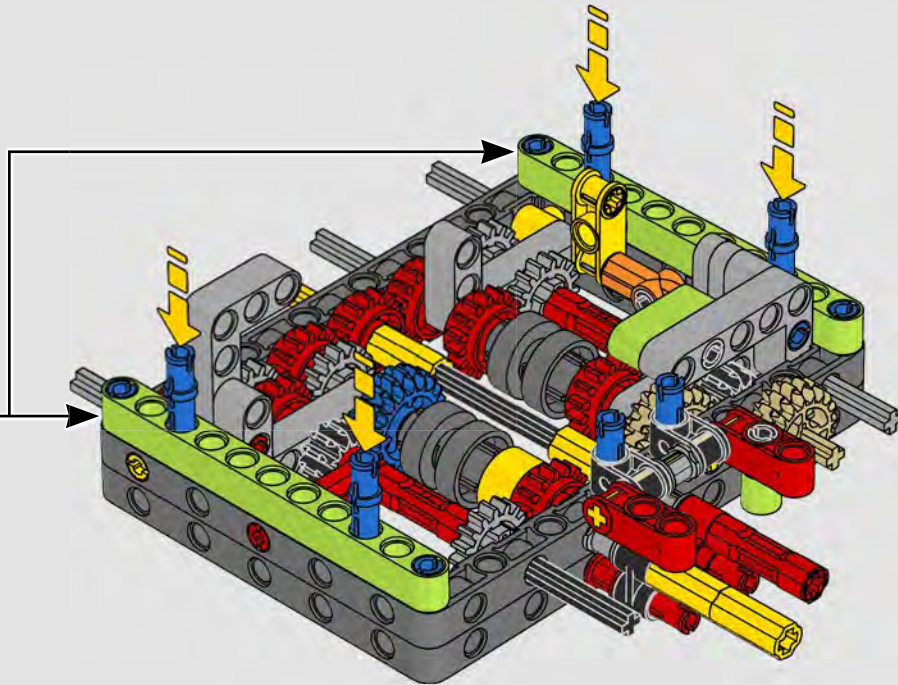
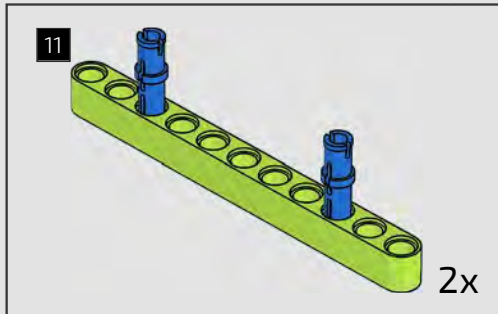

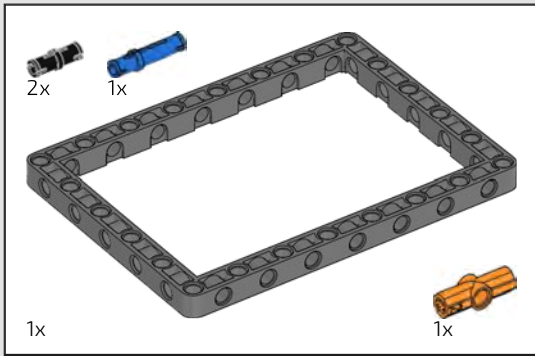

83

1

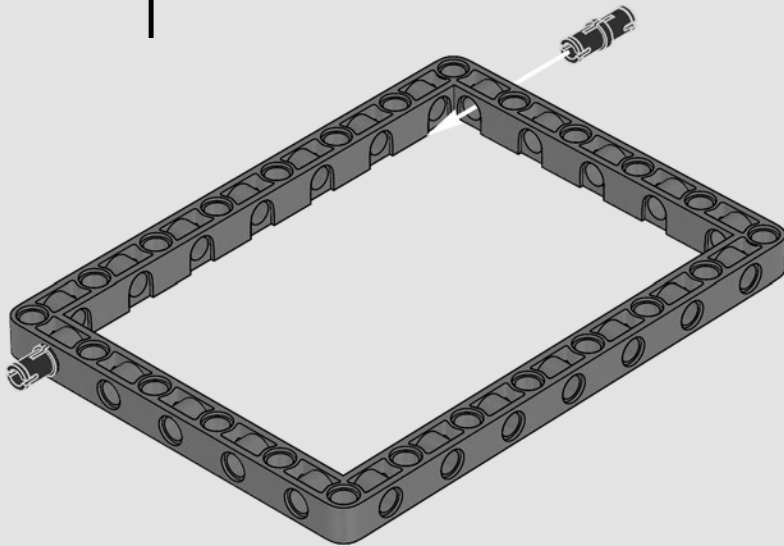

2

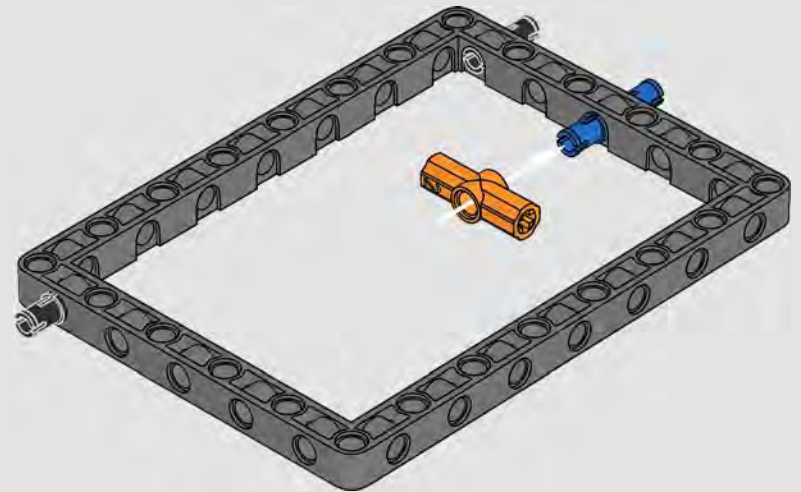

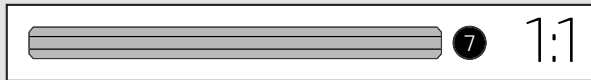
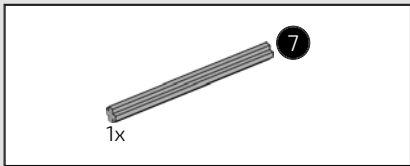
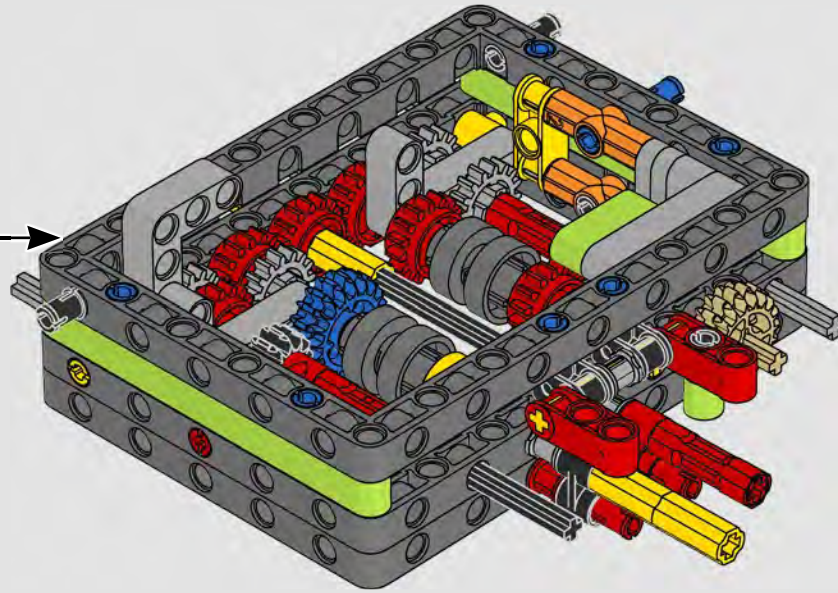

84

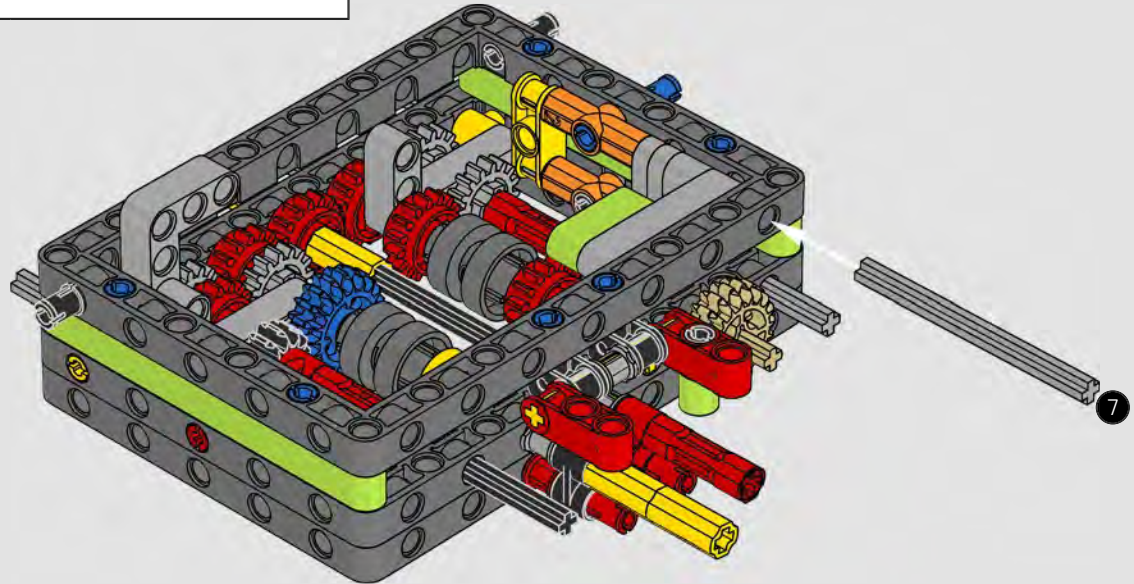

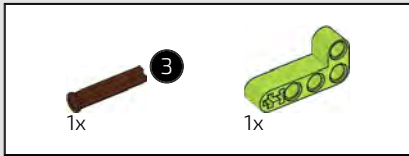

85

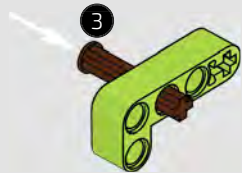

86

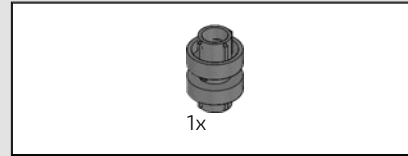
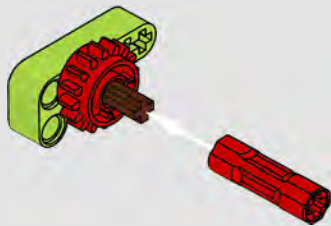

87

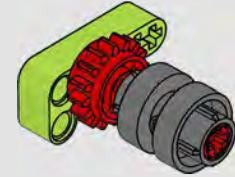

88

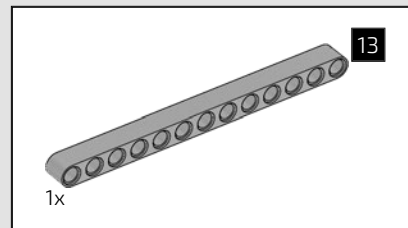
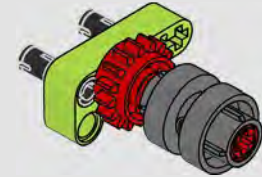

89

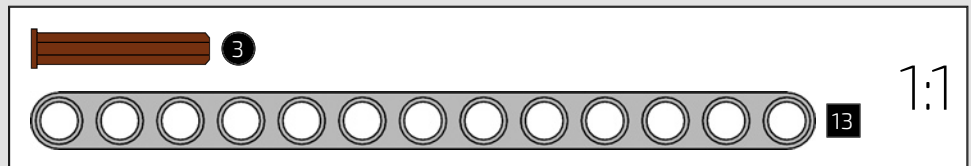
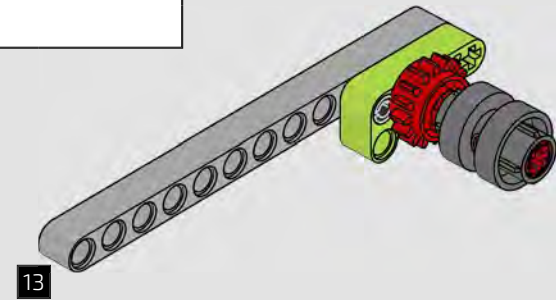

1:1

90

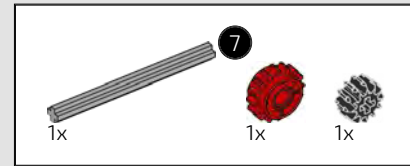
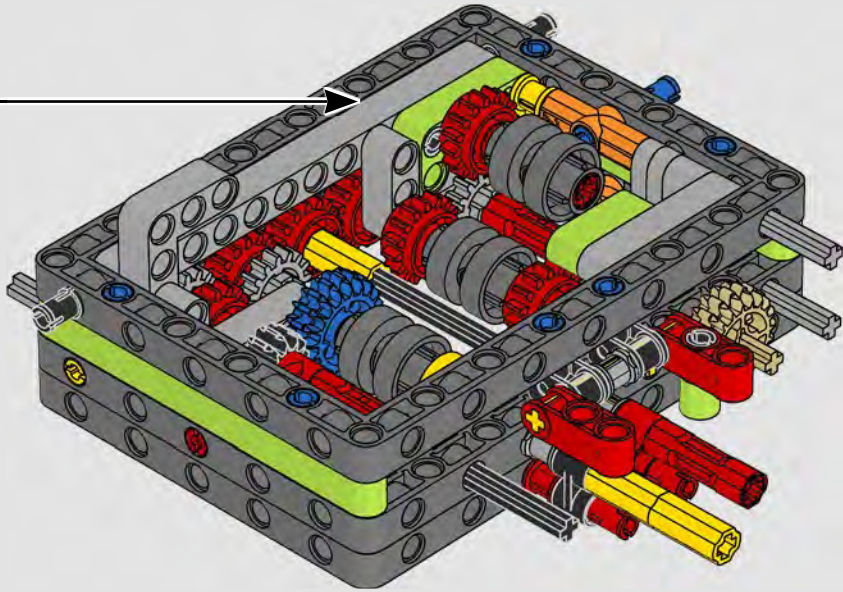

91

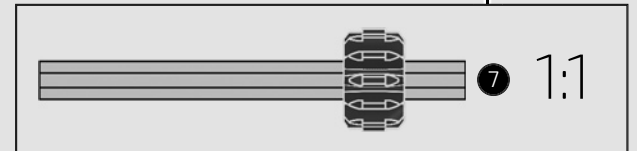
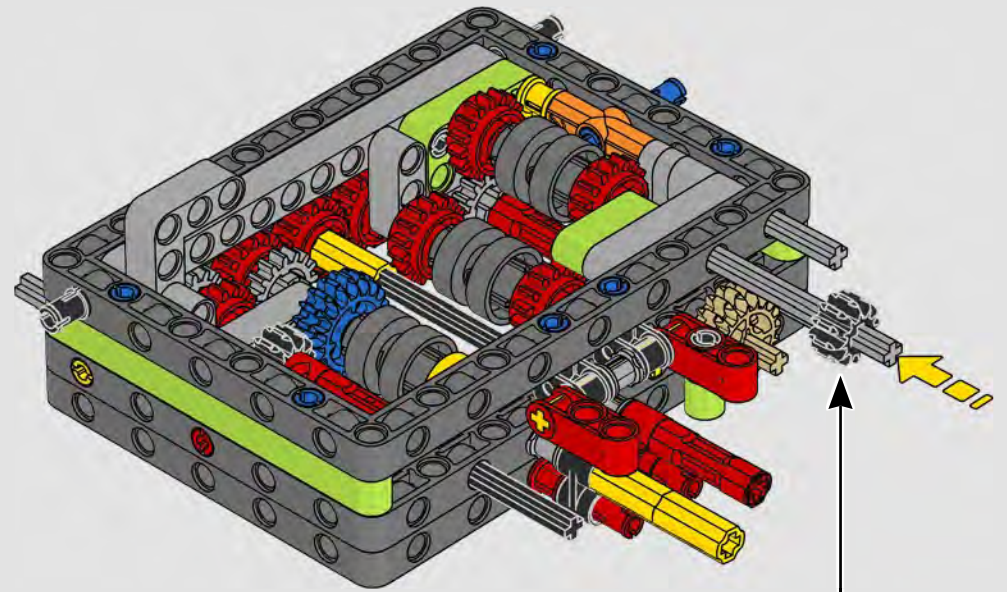

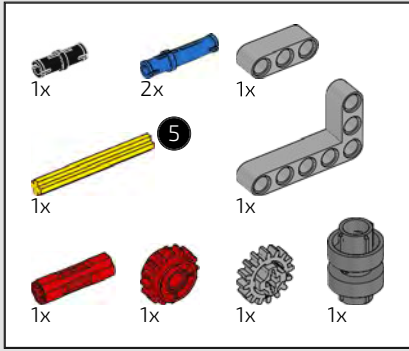

92

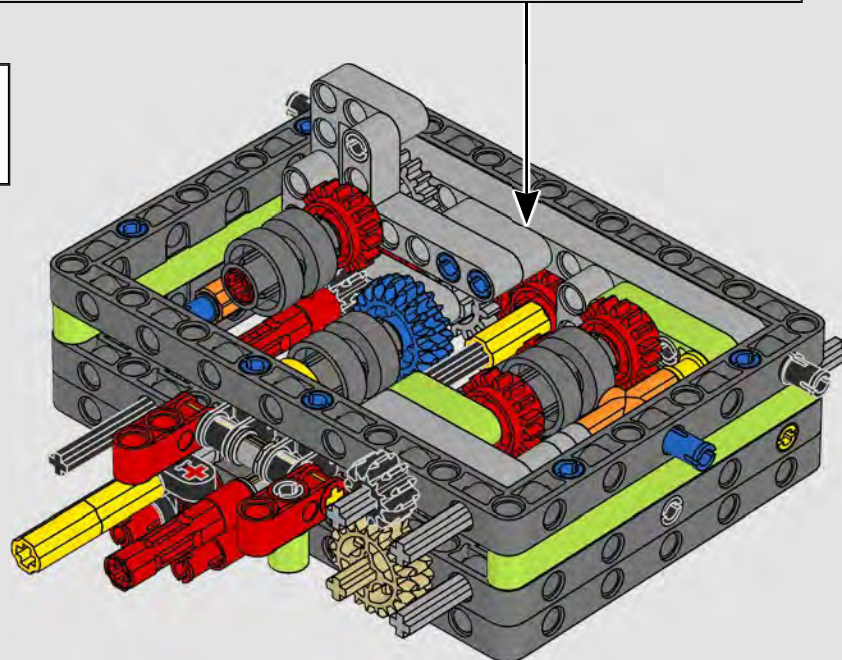
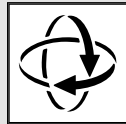
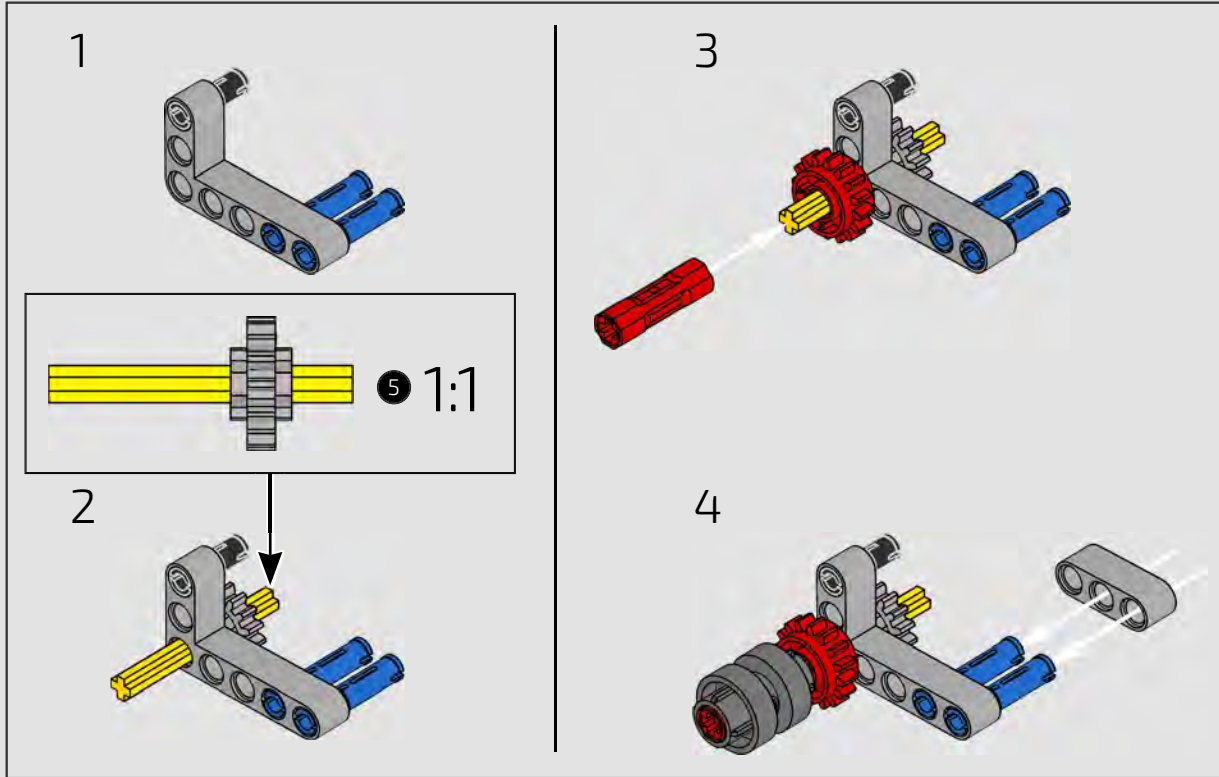

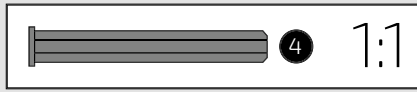
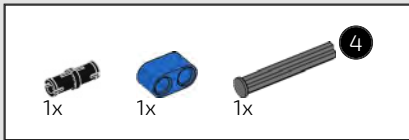

93

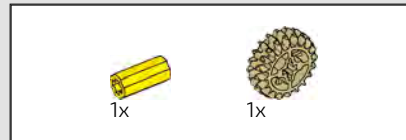
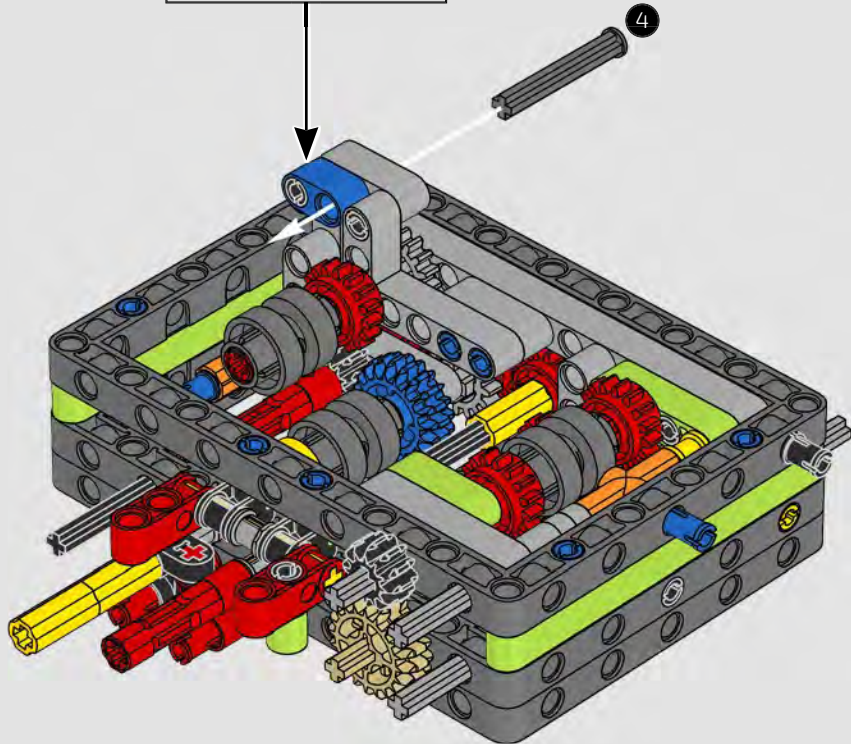
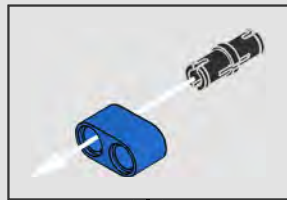

94

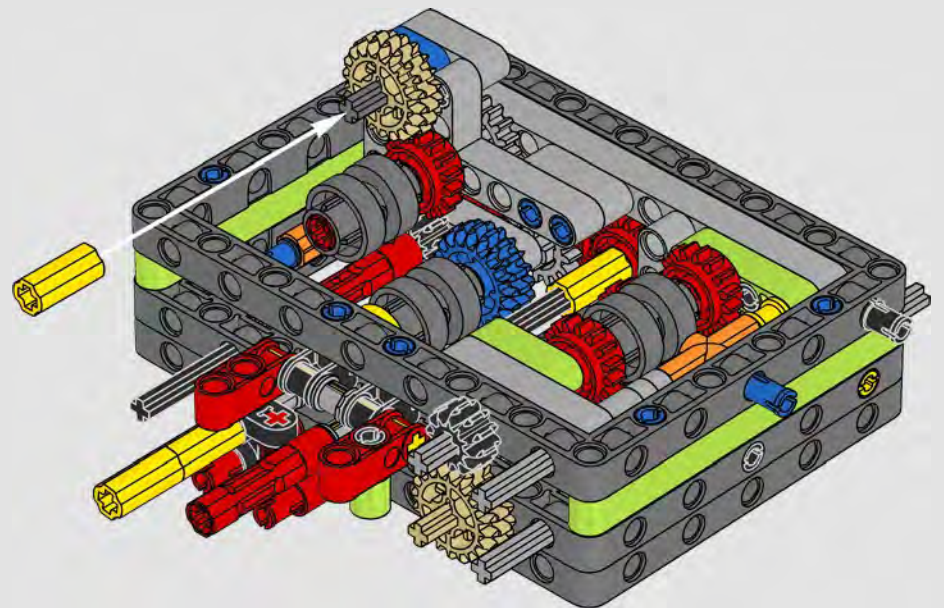

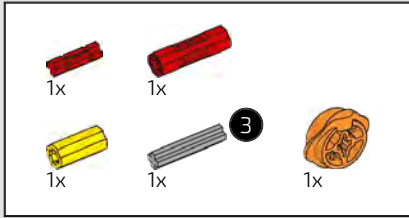

95

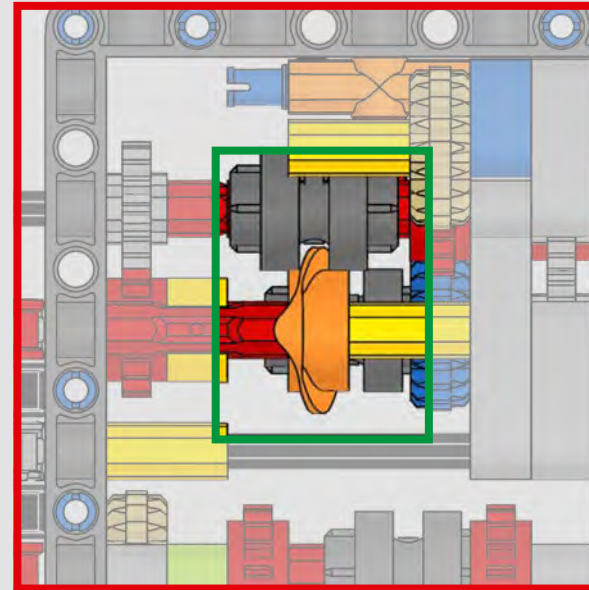
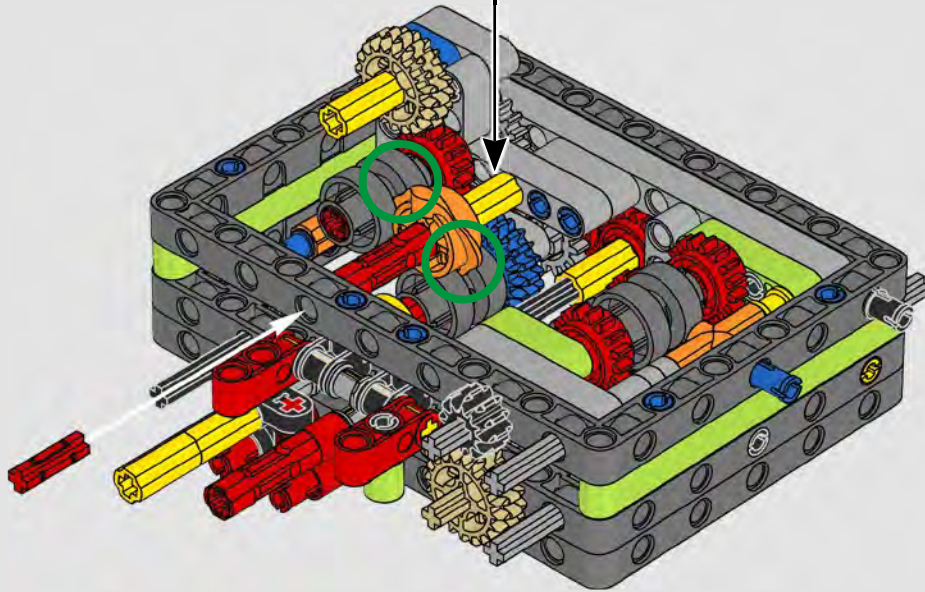
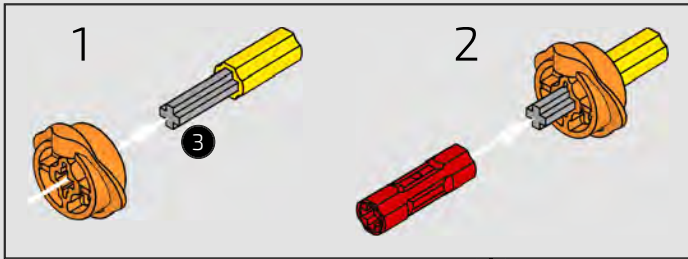

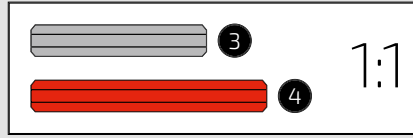
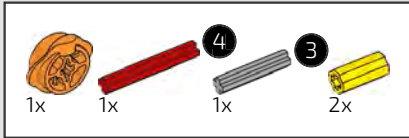

96

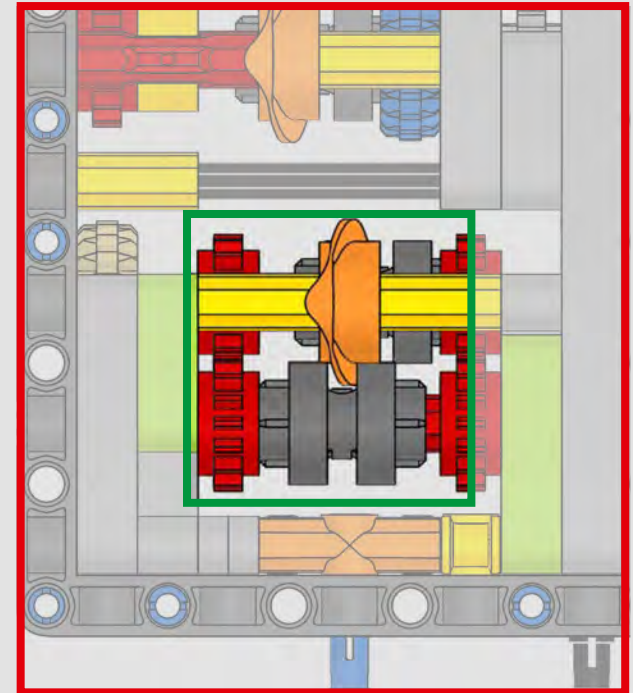
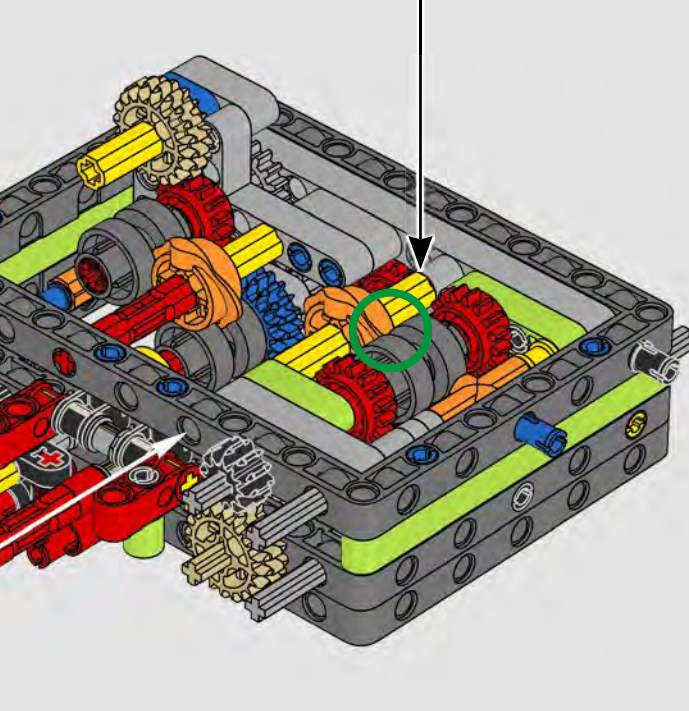
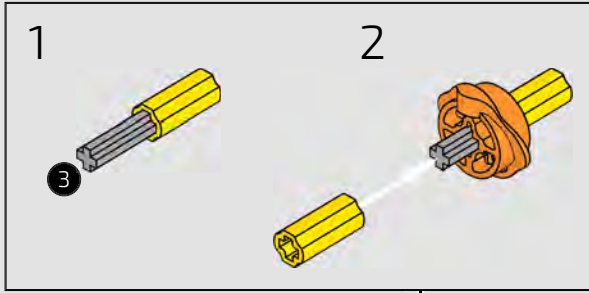

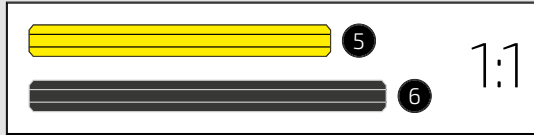
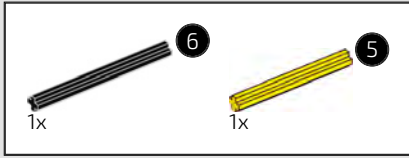

97

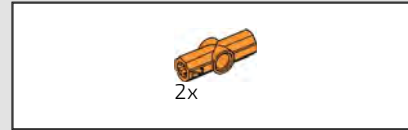
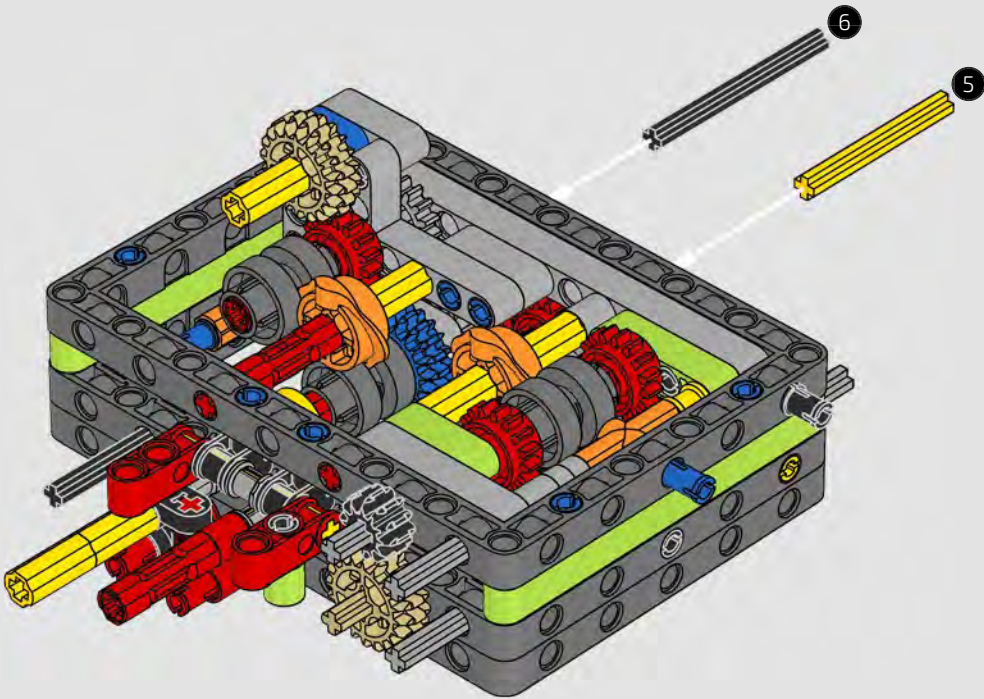

98

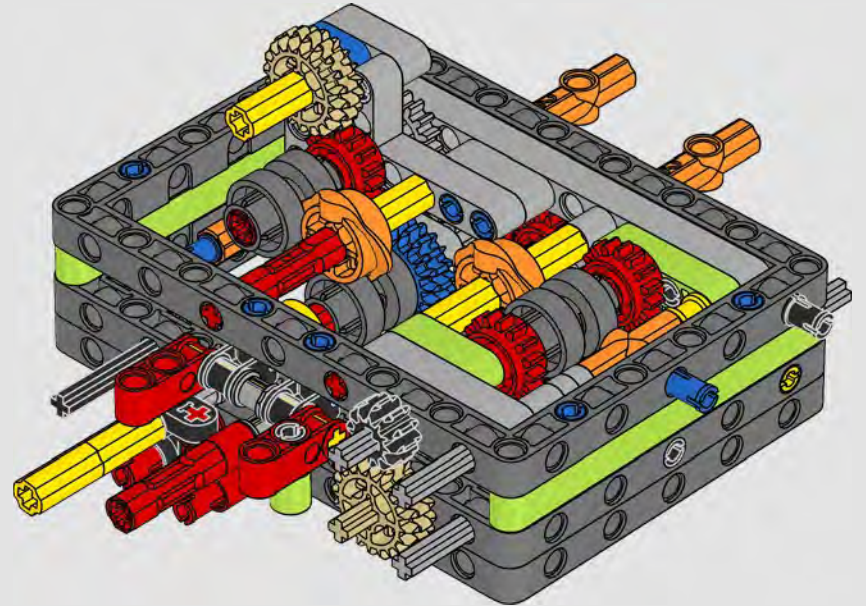

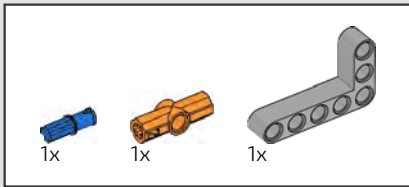

99

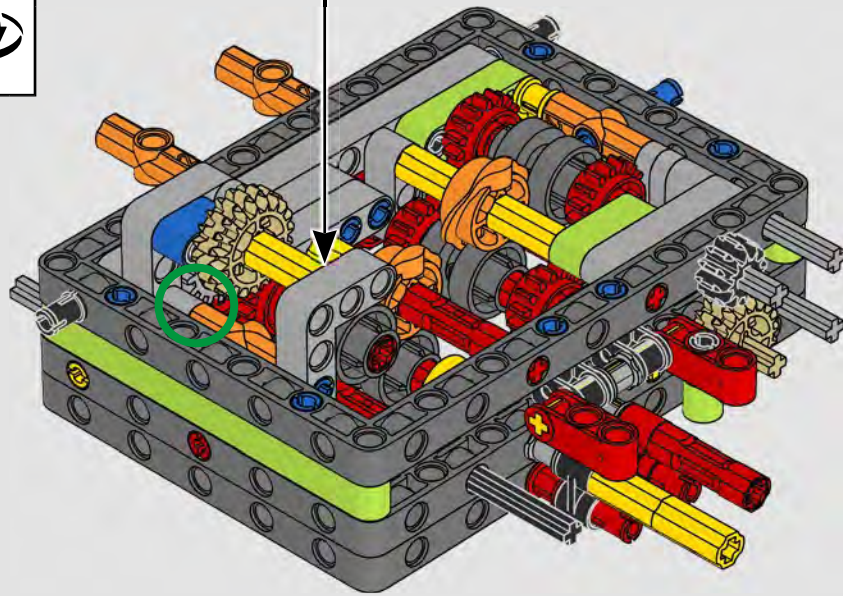
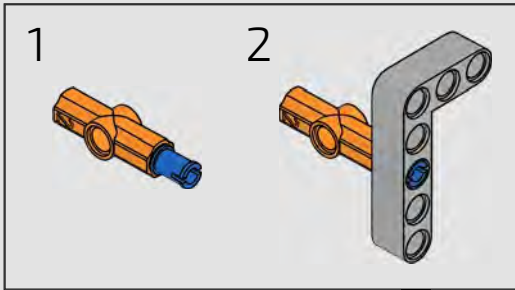

100

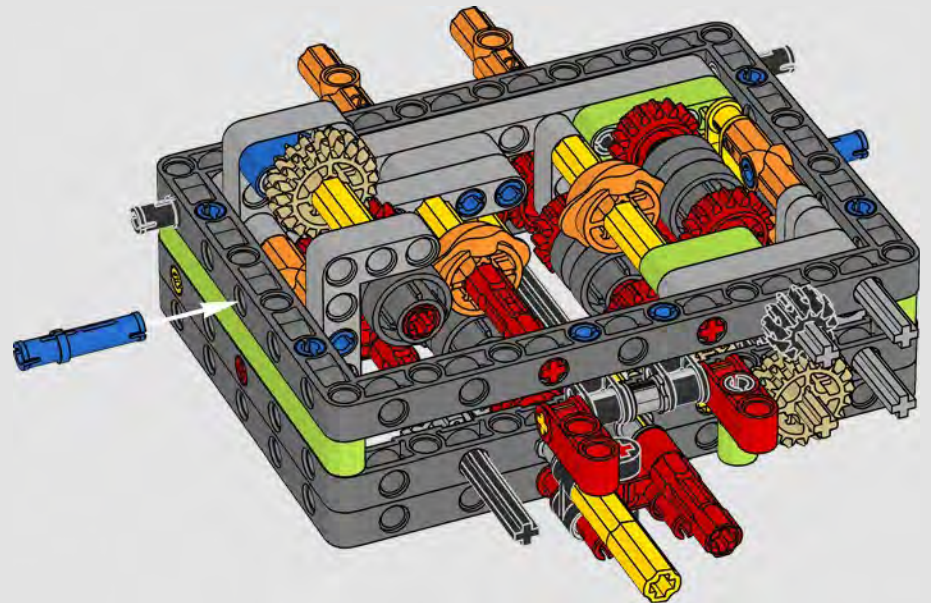

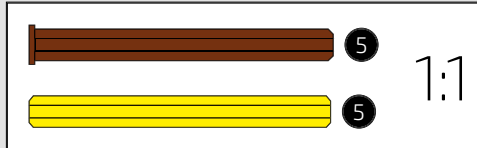
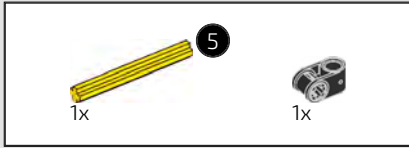

101

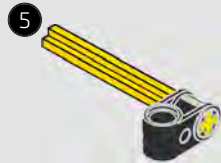

102

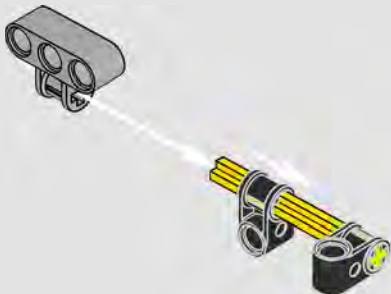

103

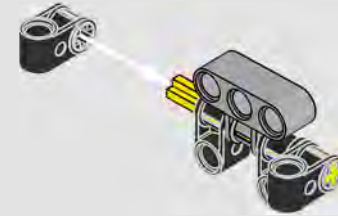

104

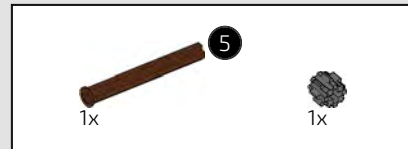
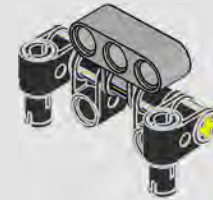

105

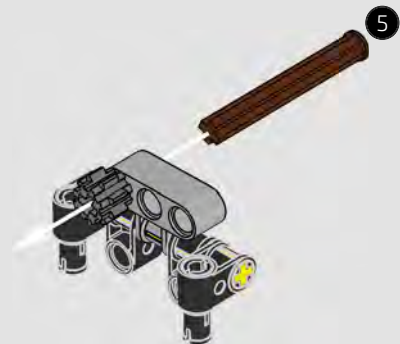

106

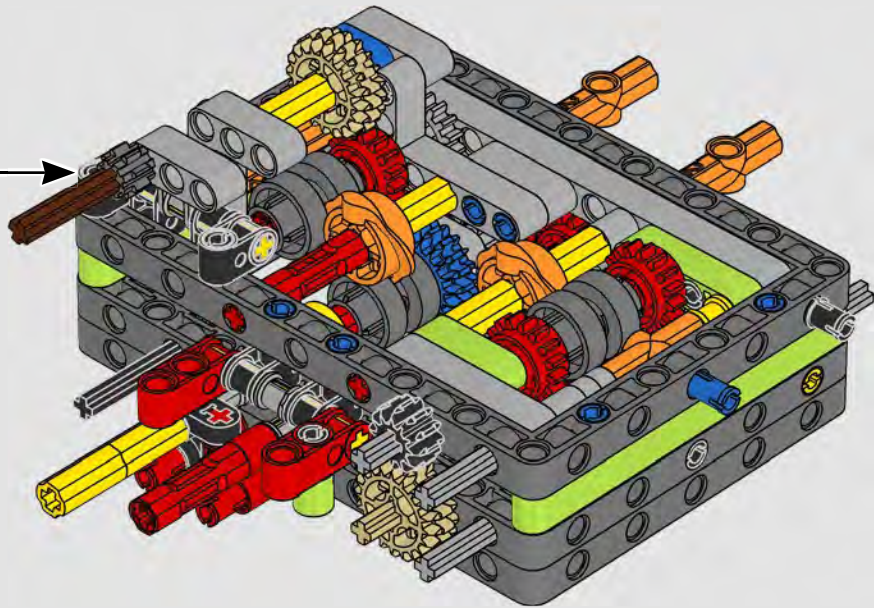

107

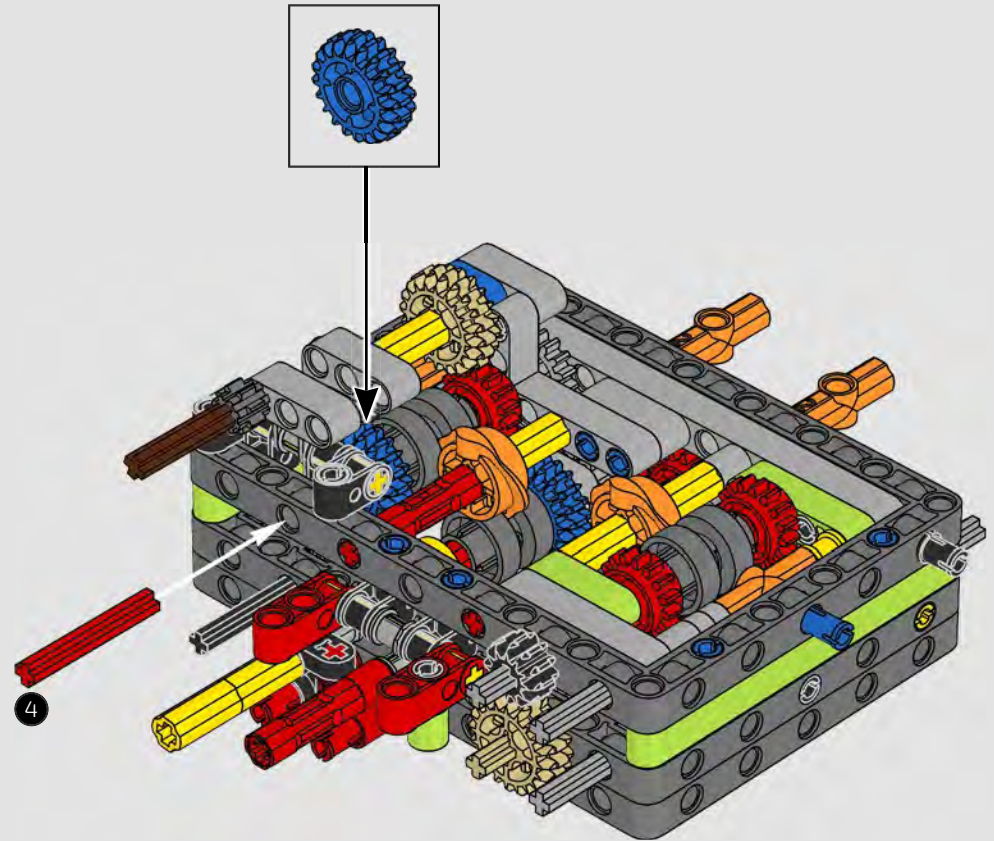
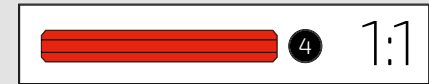
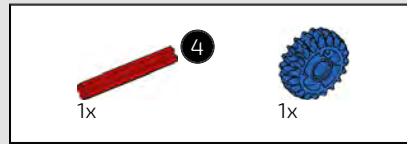

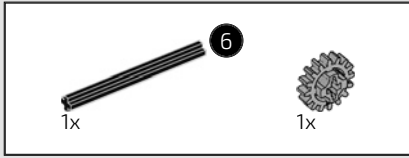

108

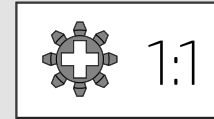
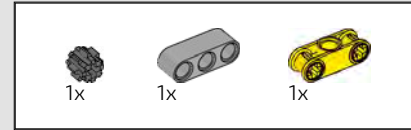
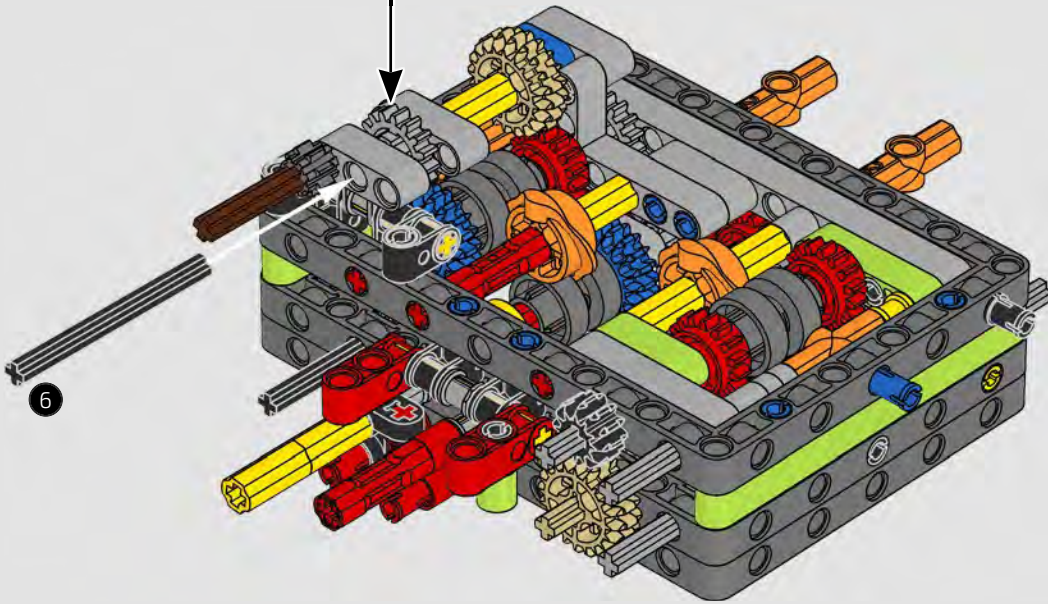
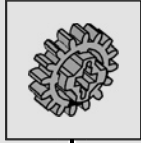

109

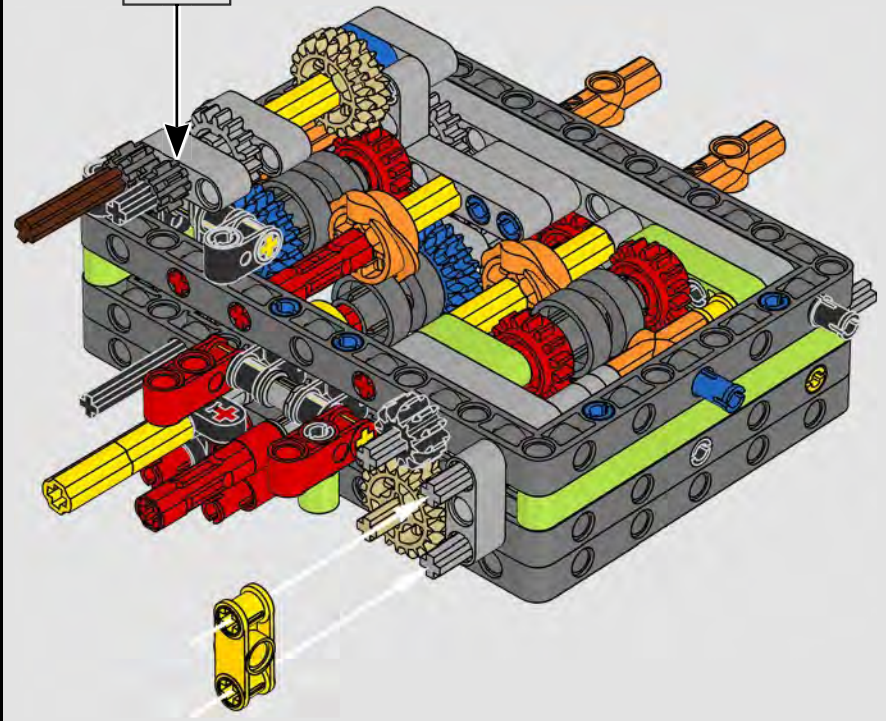
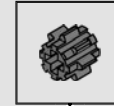

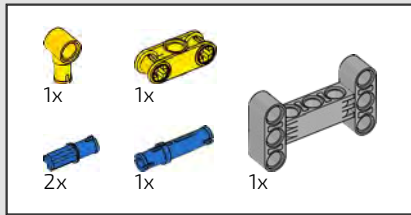

110

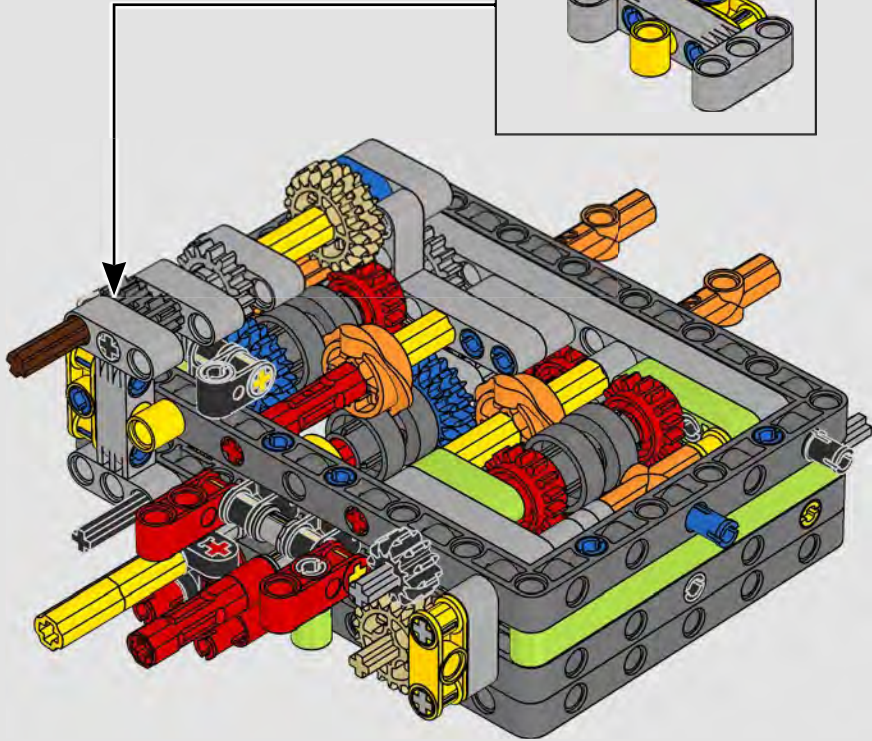
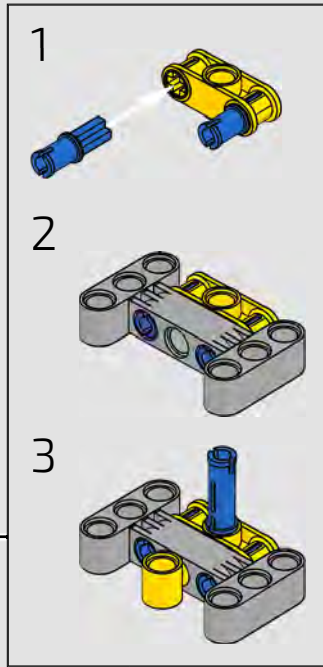

111

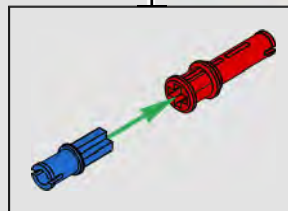
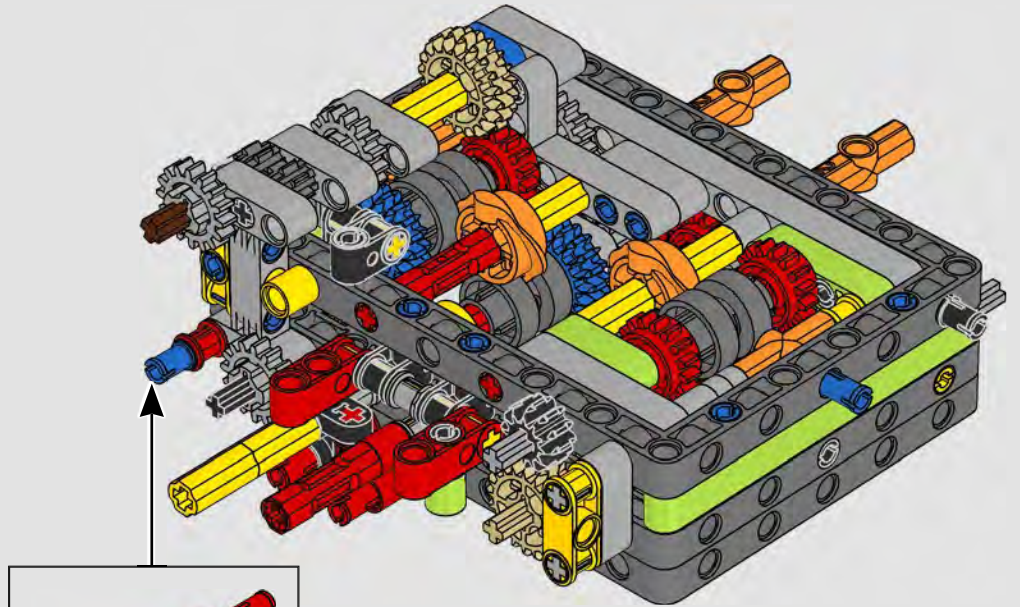



112

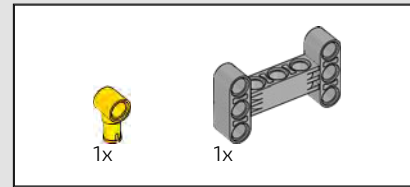
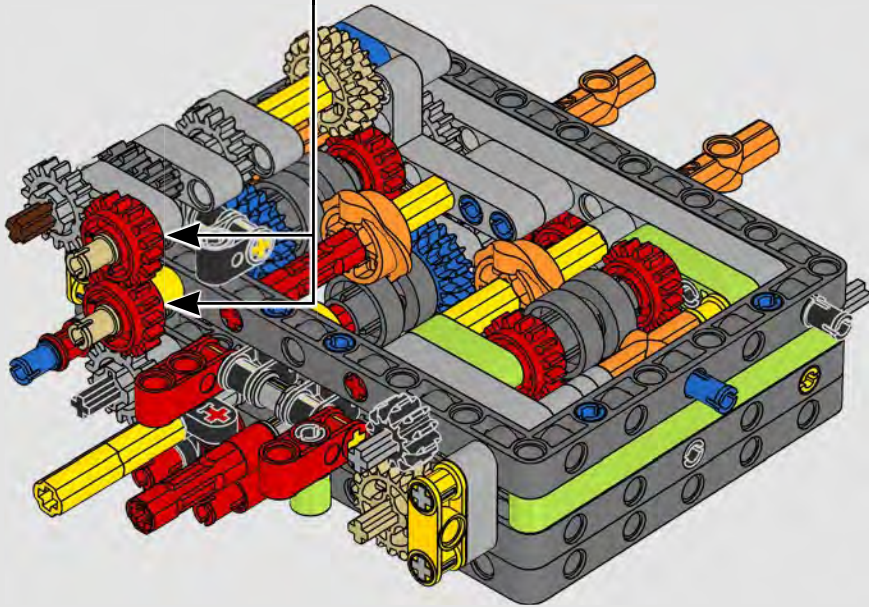
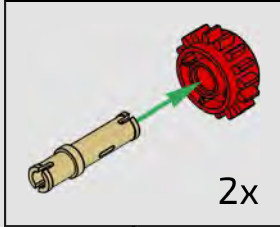

113

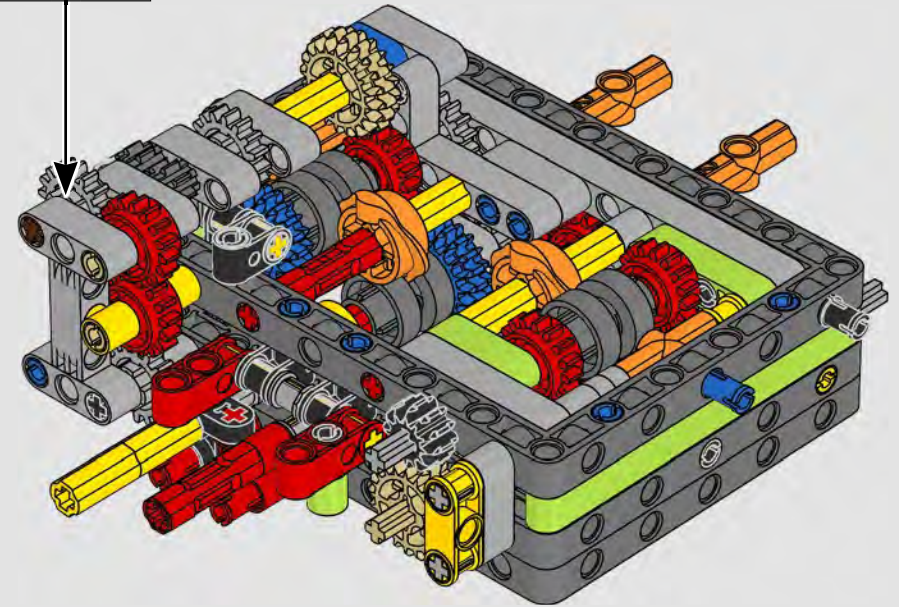
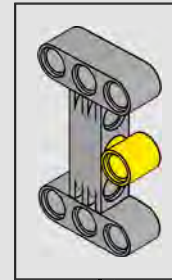

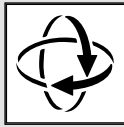
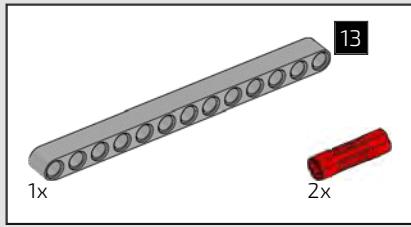

114

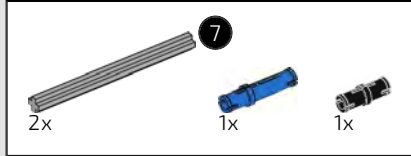
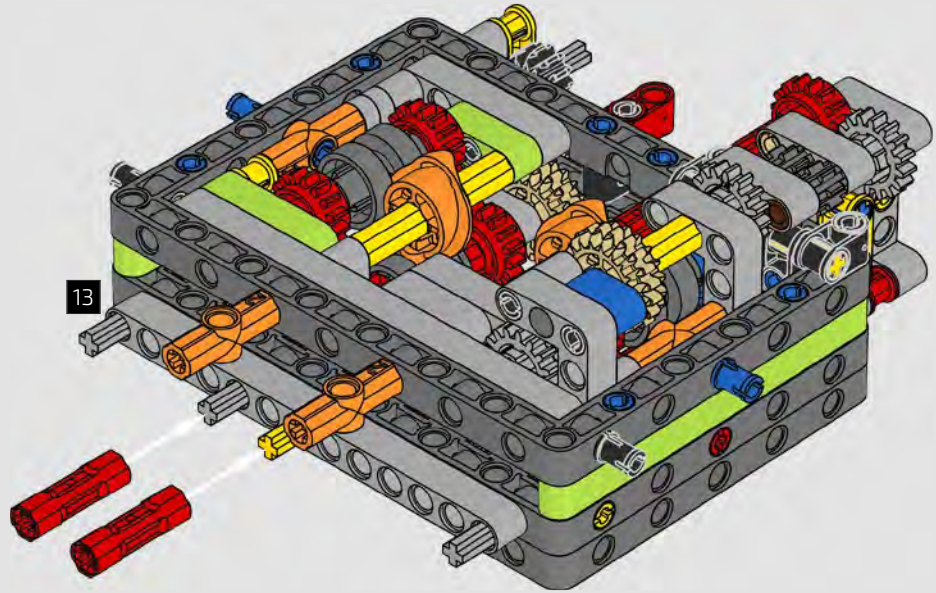

115

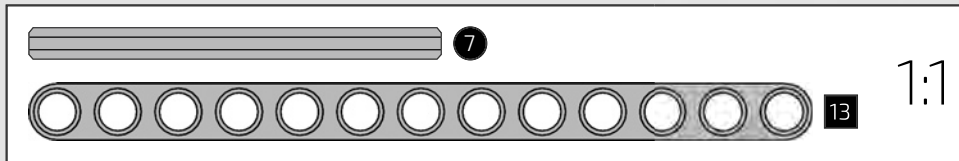
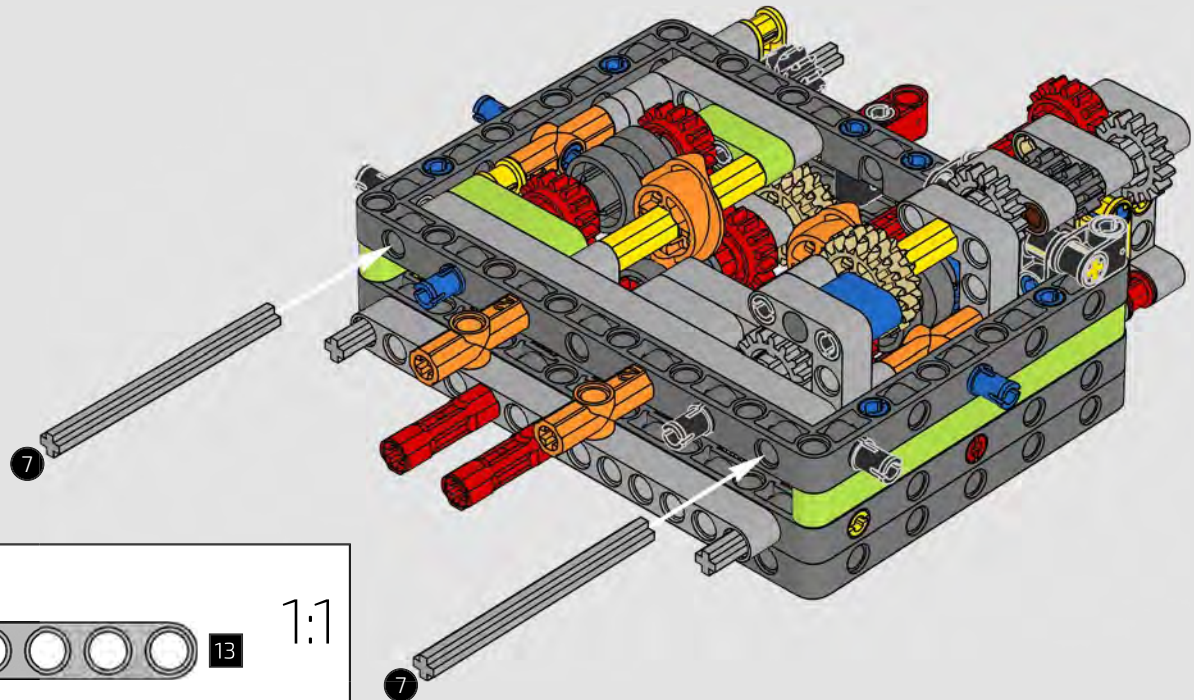

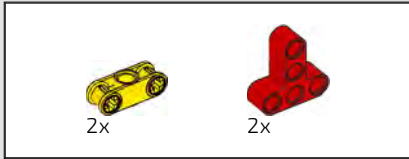

116

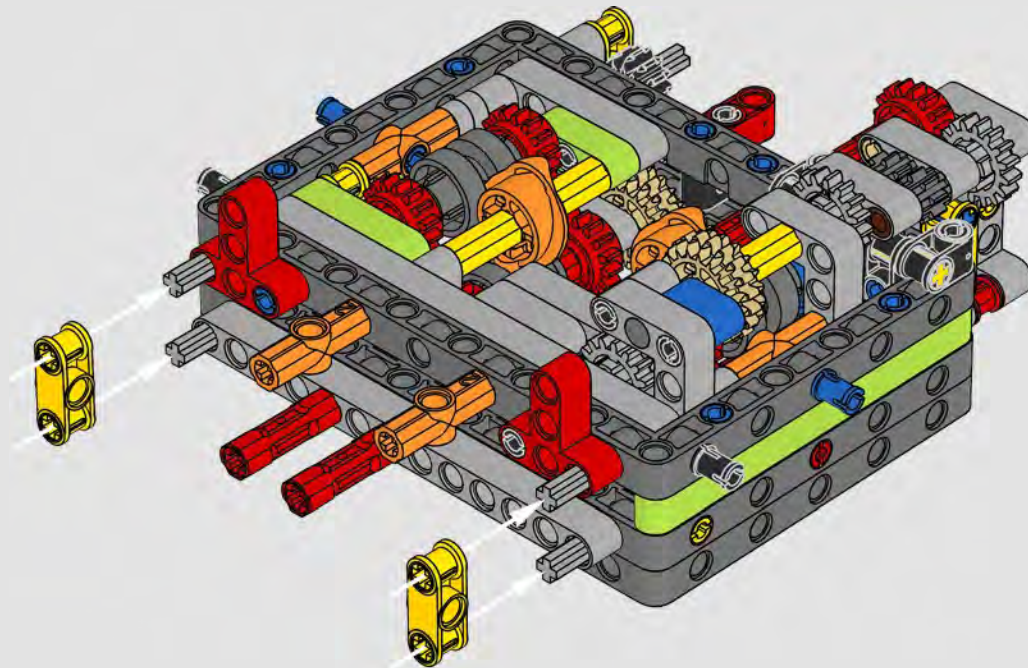

117

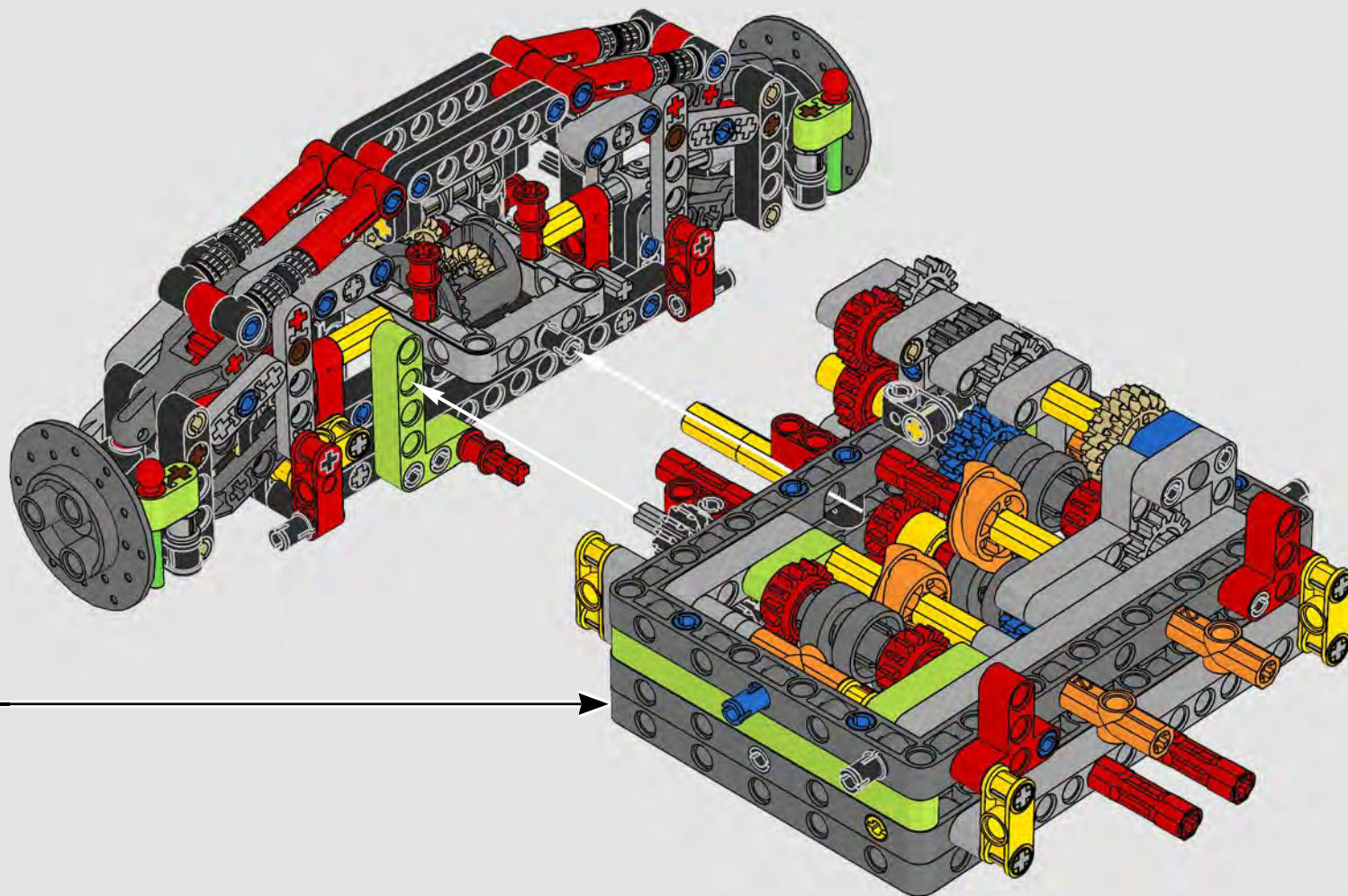

118

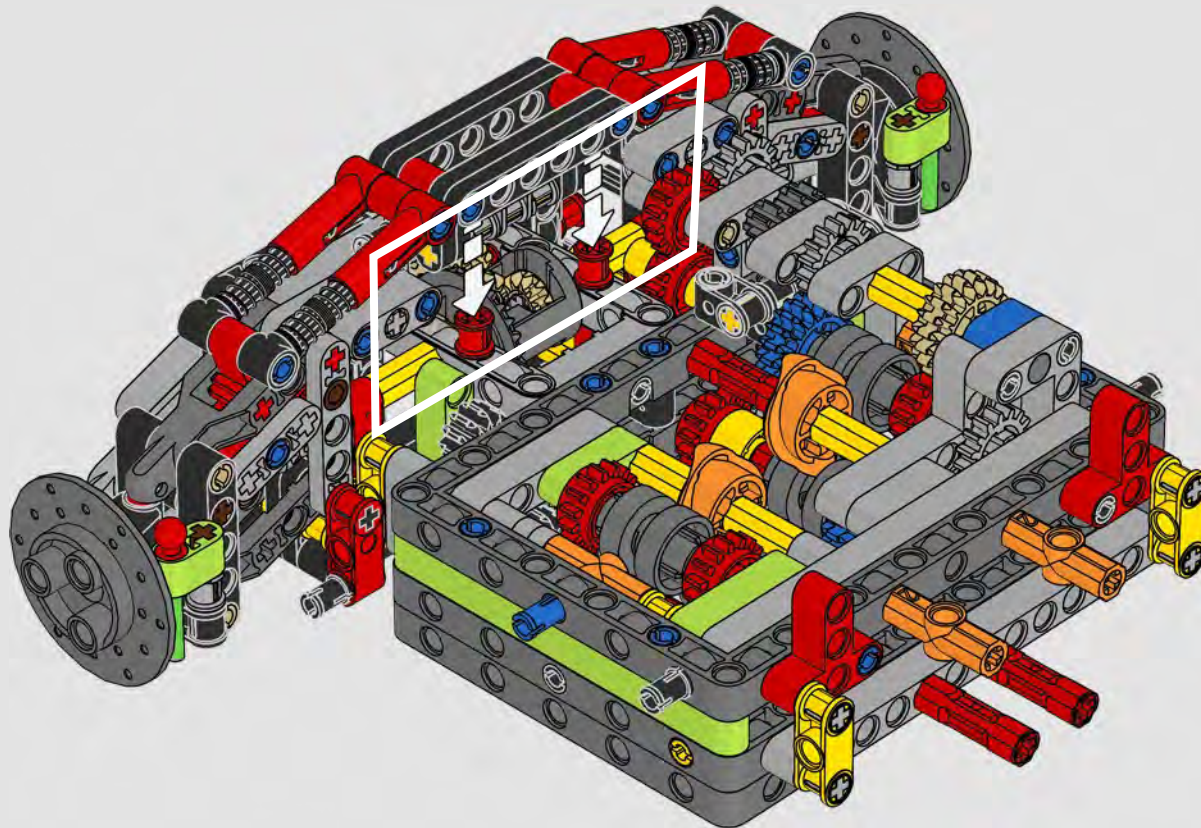

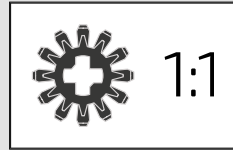
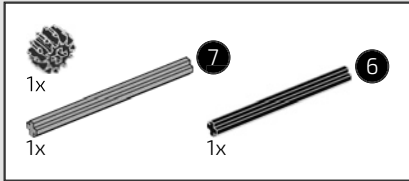

119

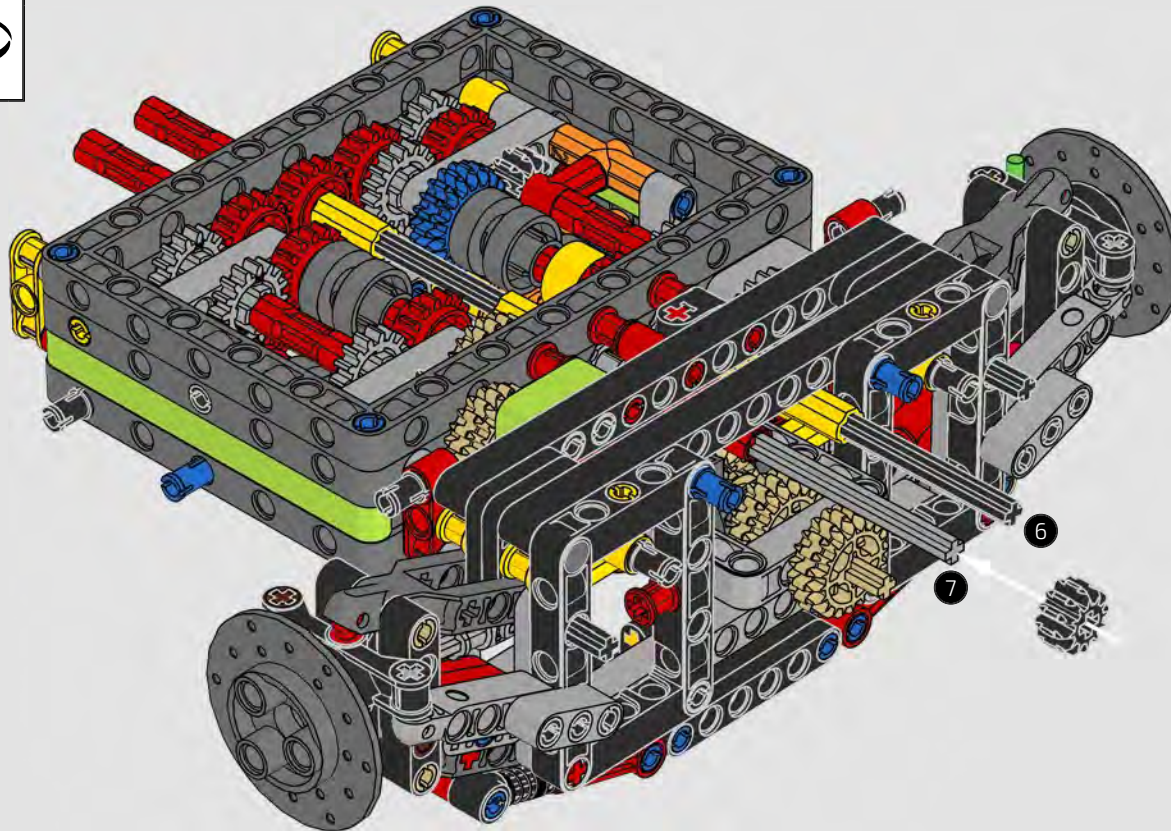
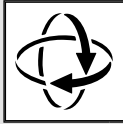

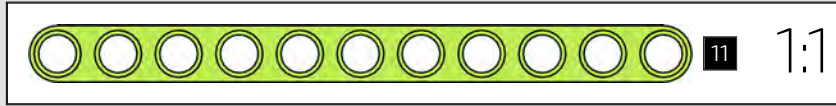
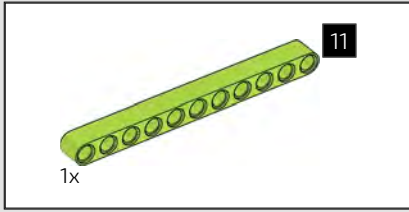

120

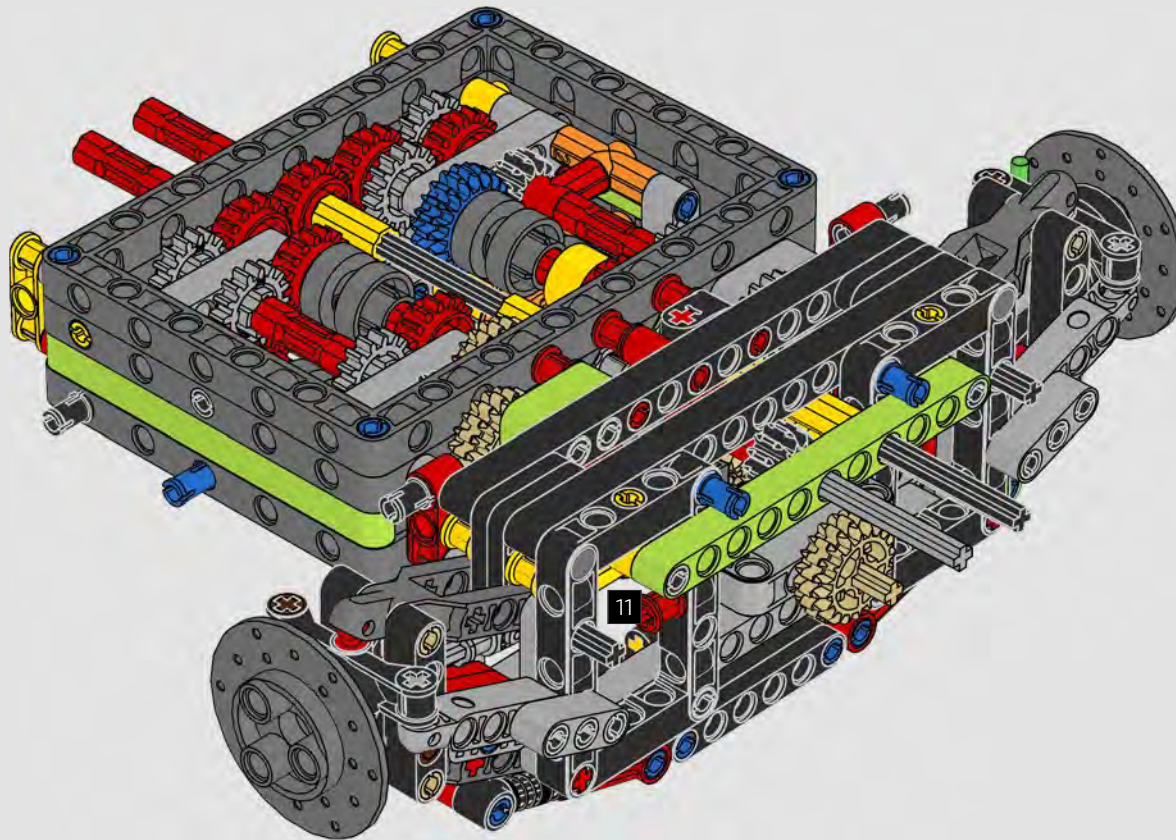



121

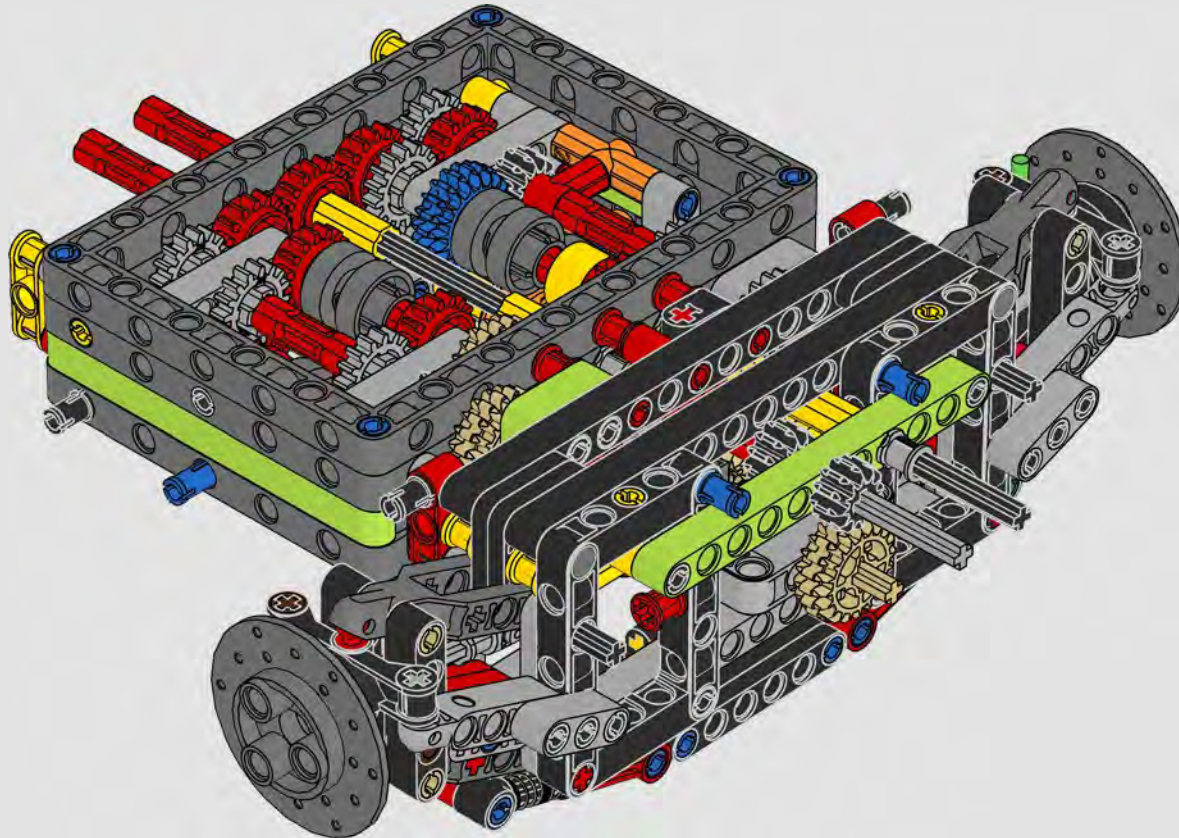

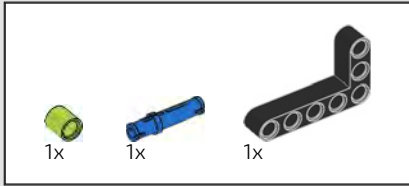

122

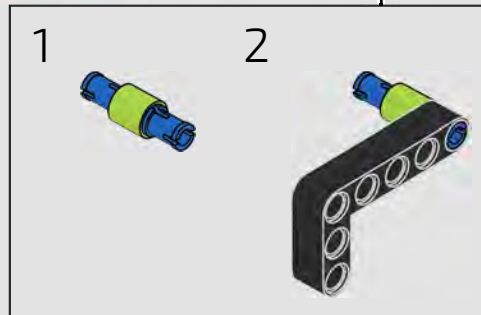
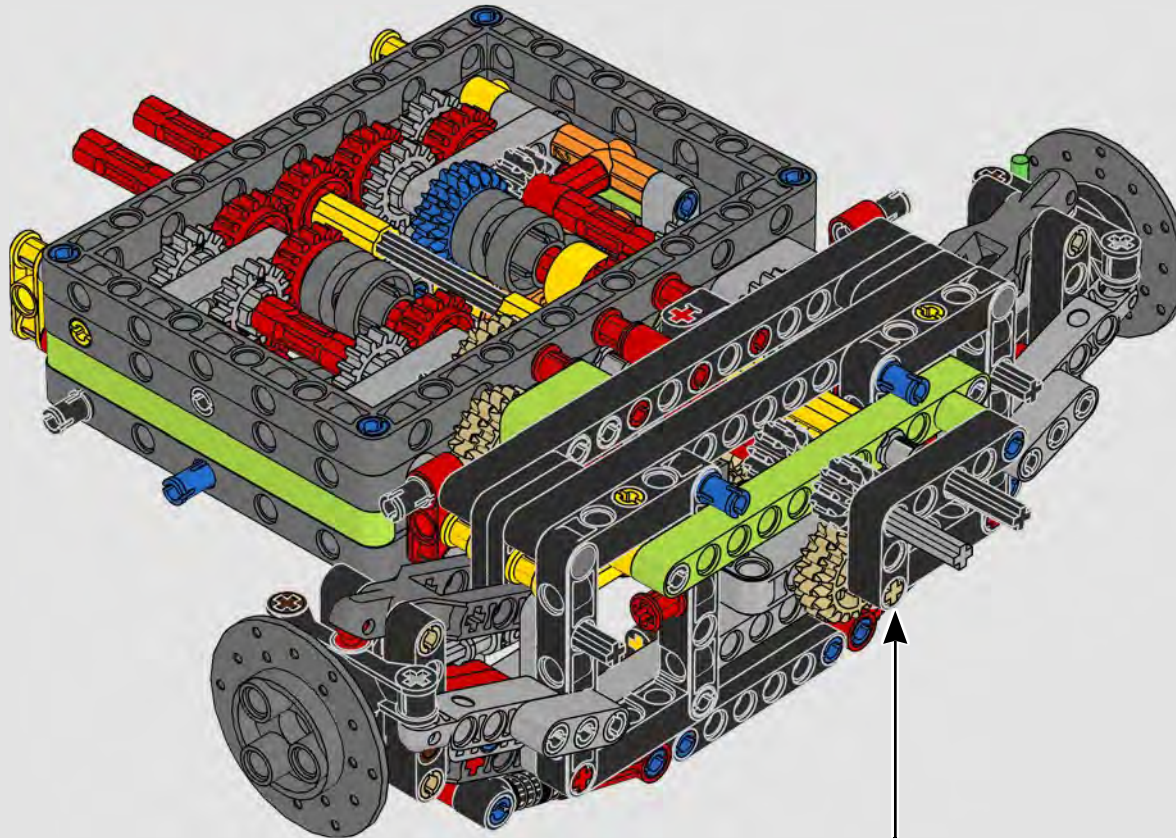

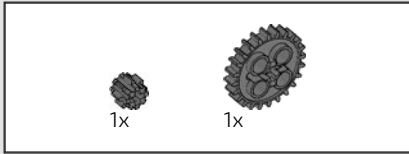

123

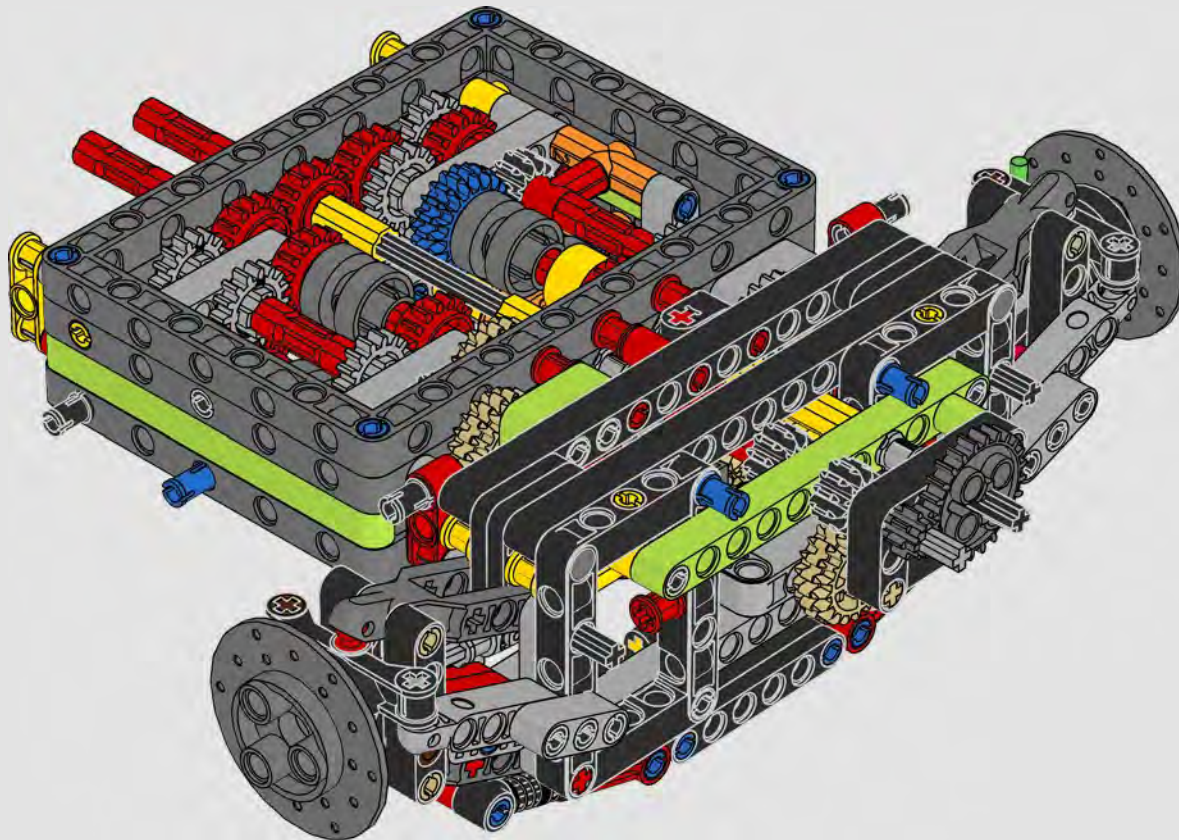

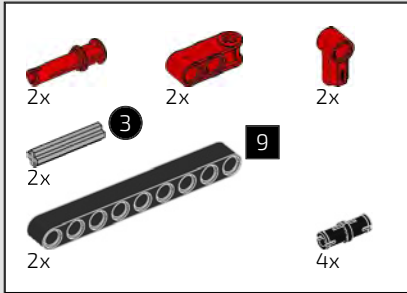

124

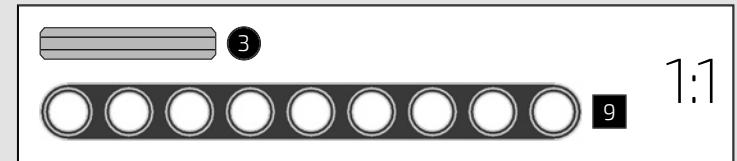
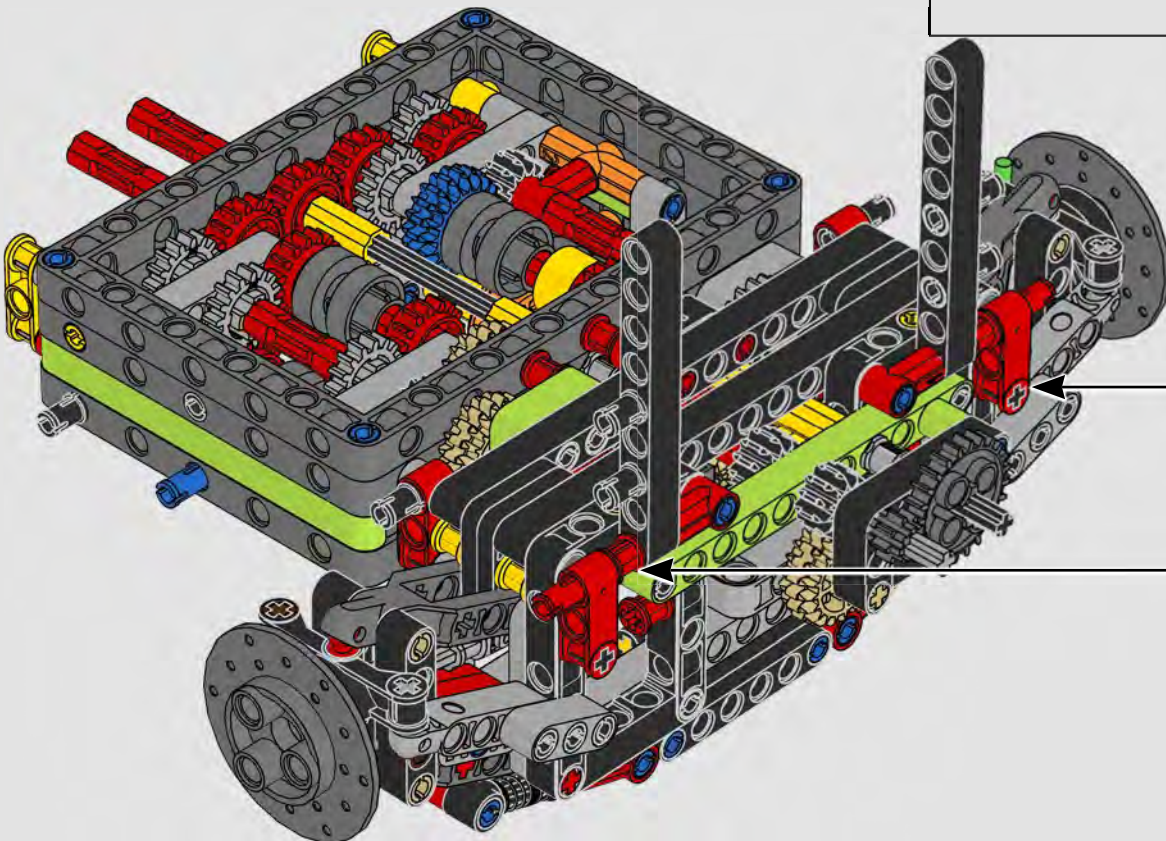
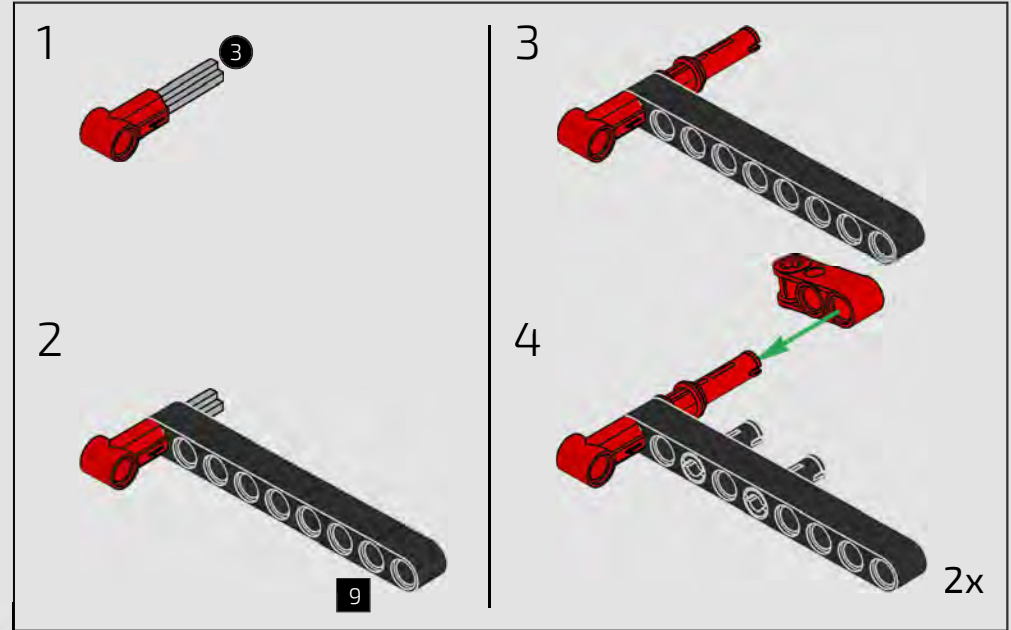

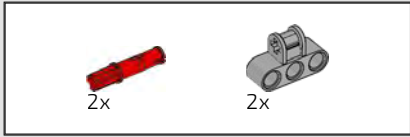

125

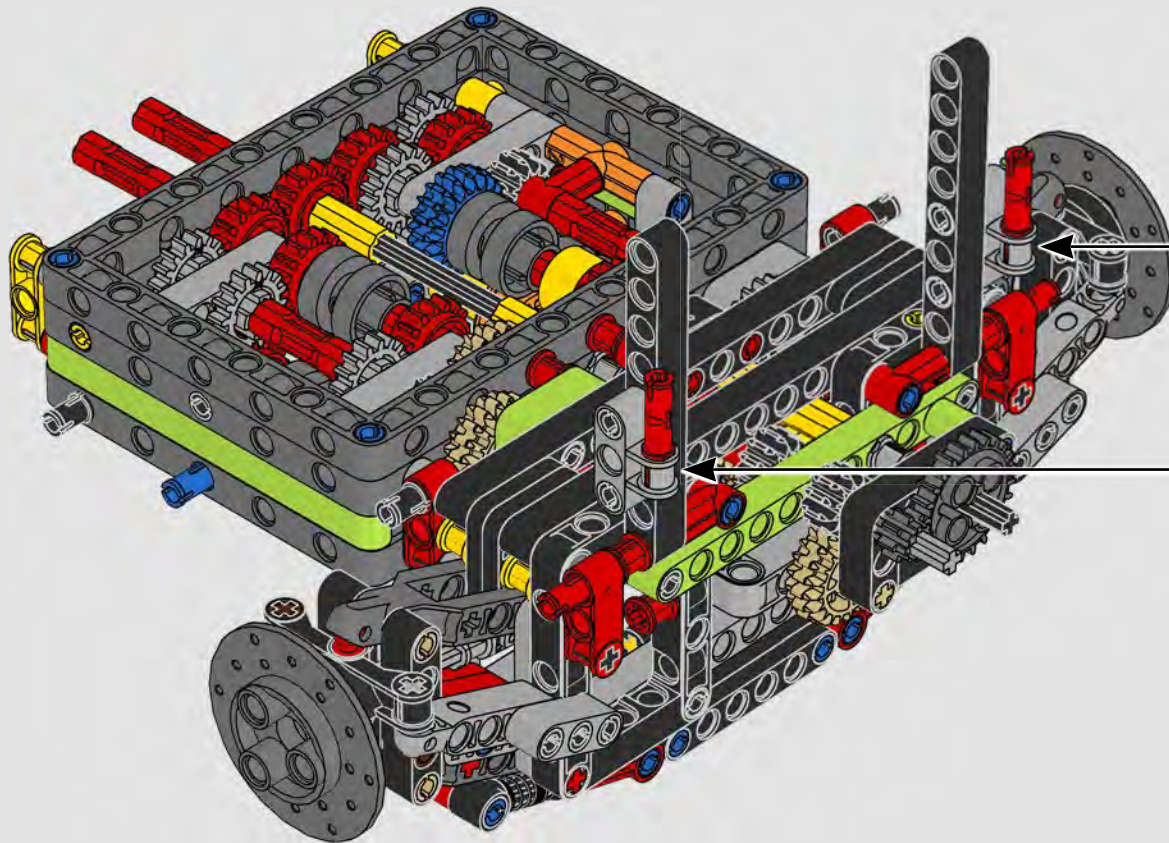

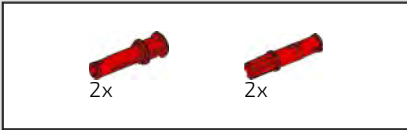

126

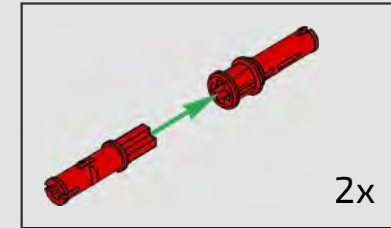
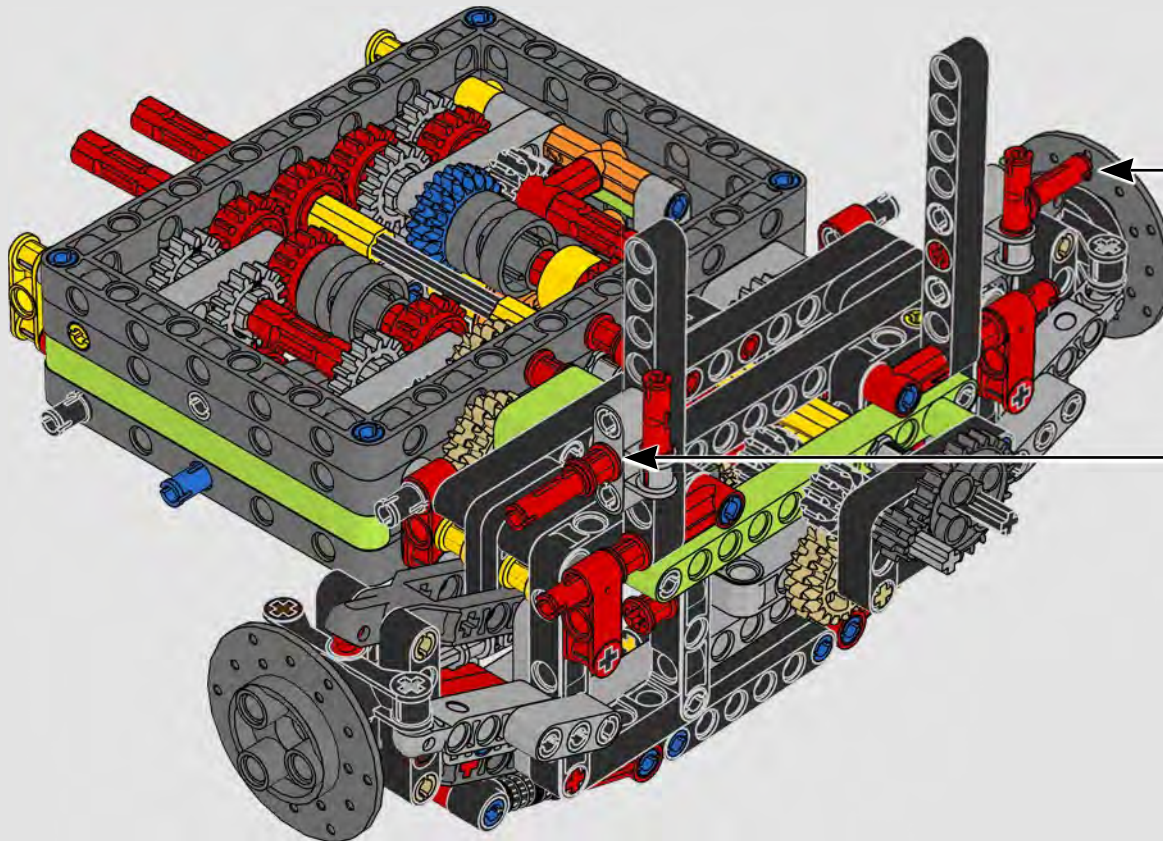

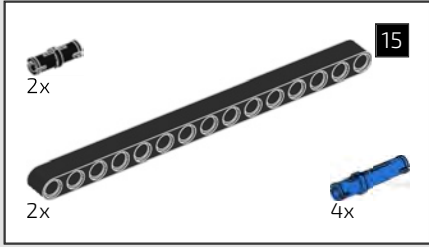

127

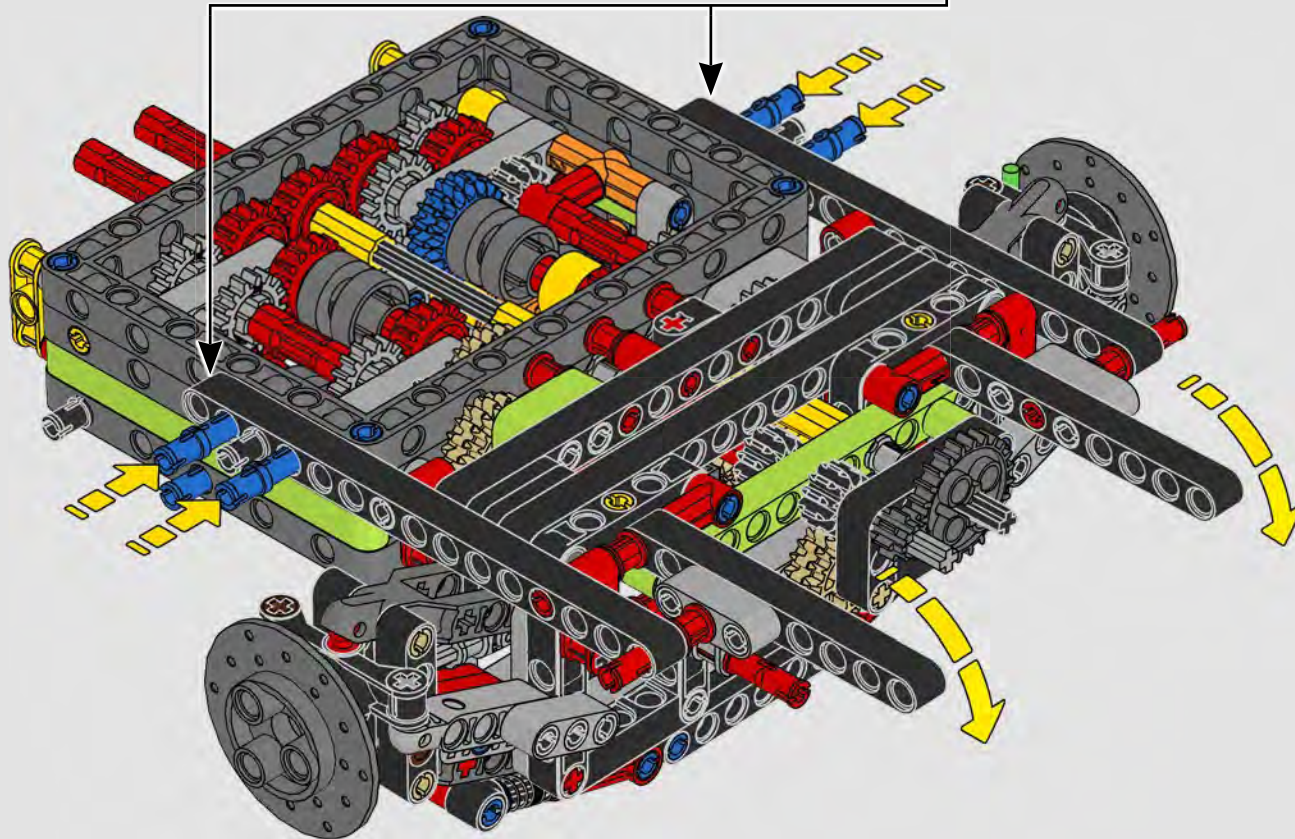
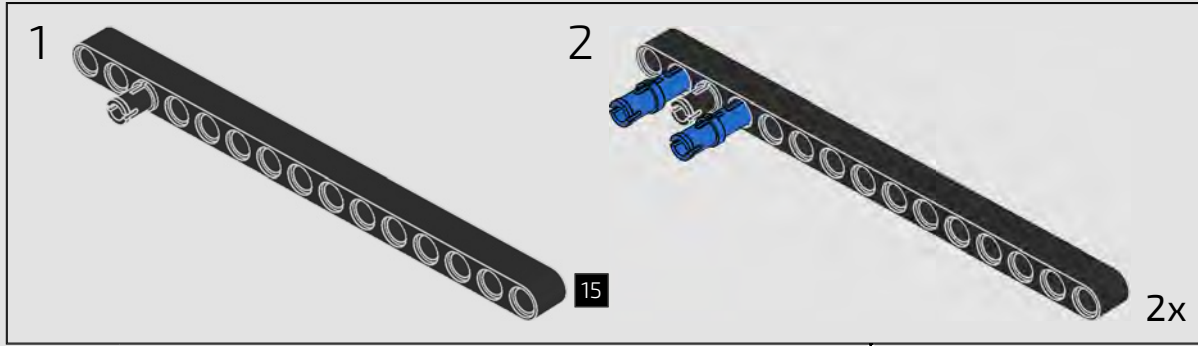
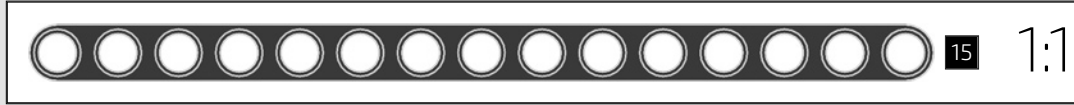

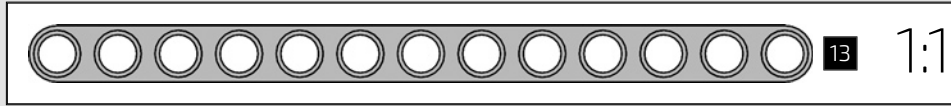
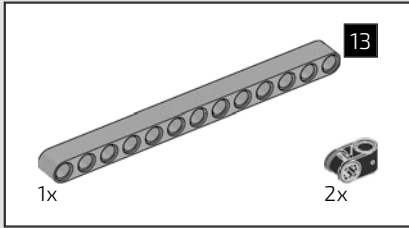

128

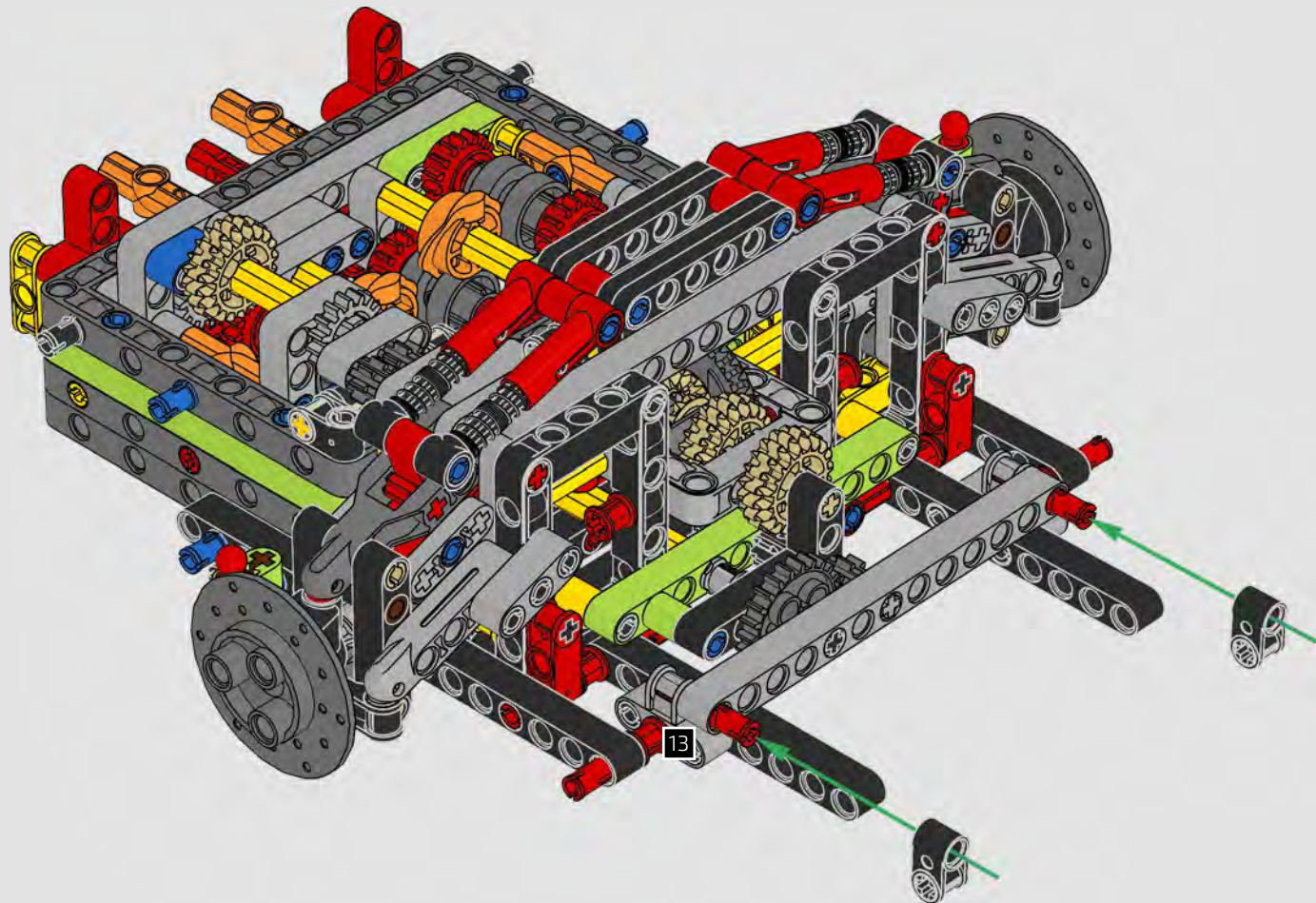

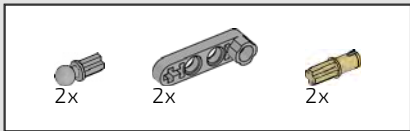

129

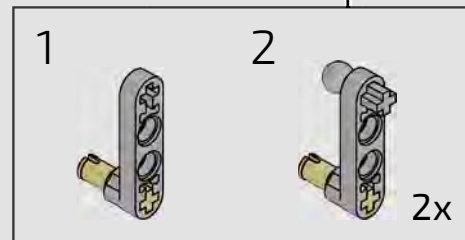
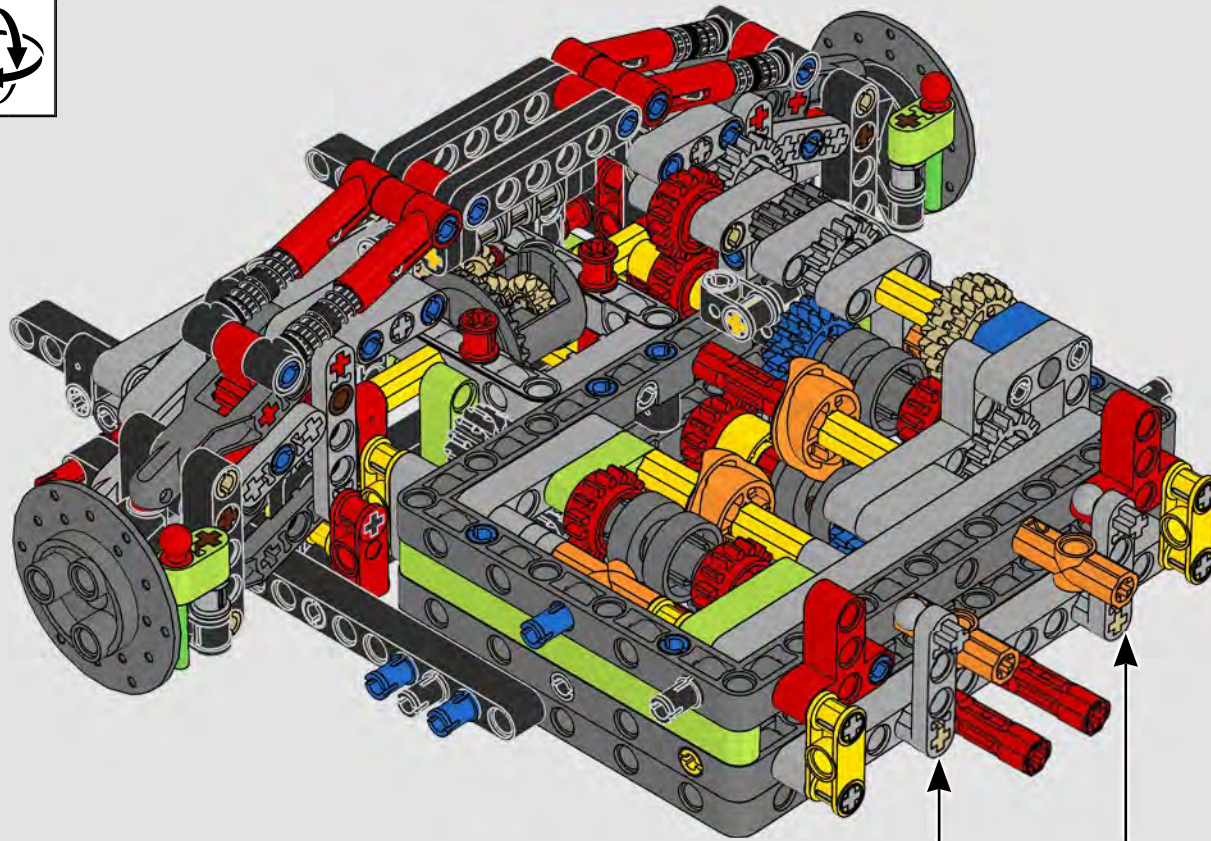

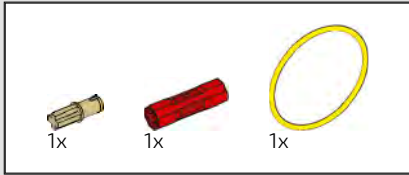

130

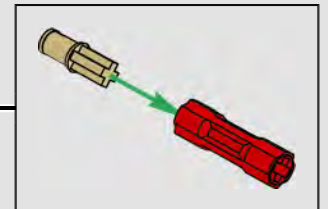
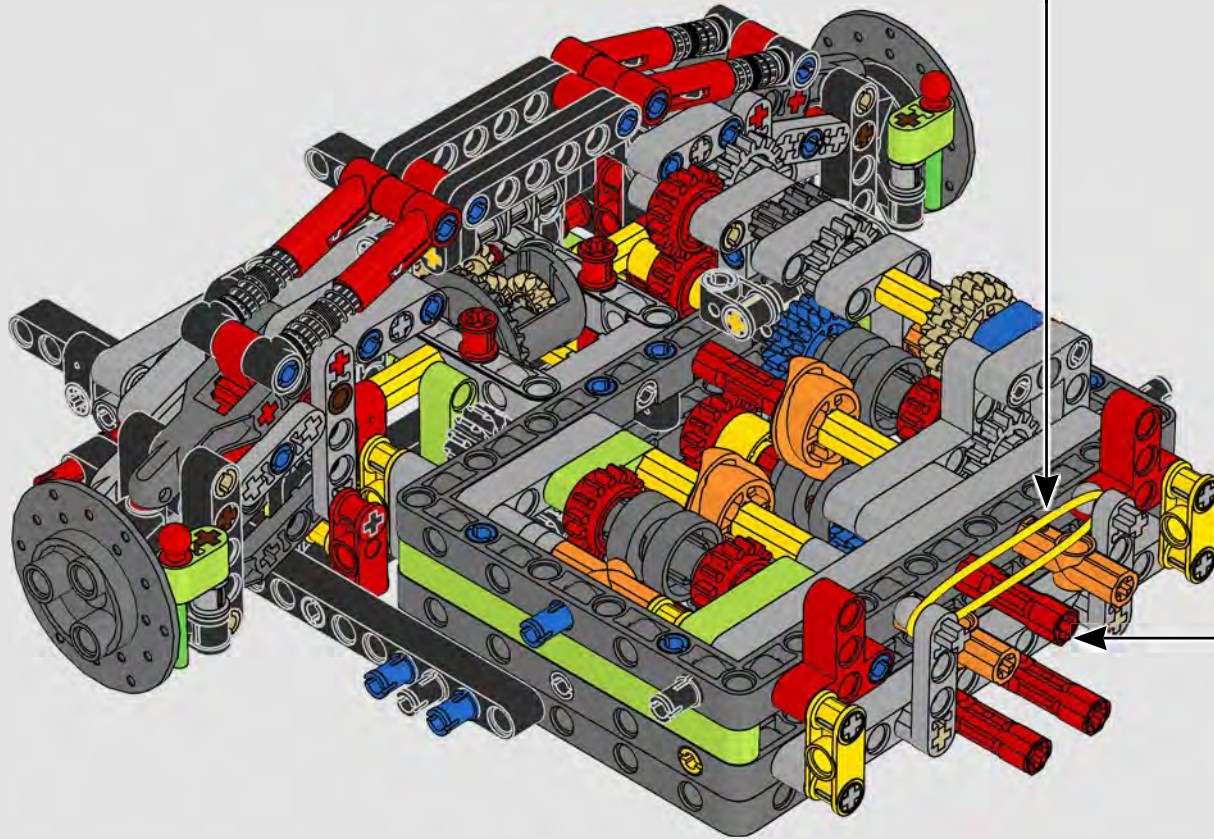
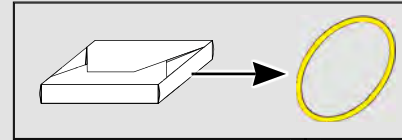

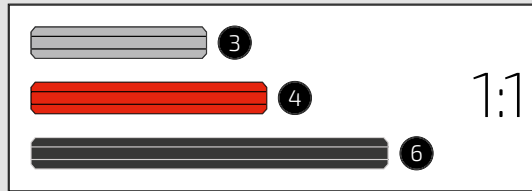
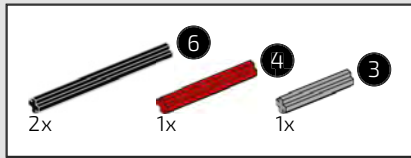

131

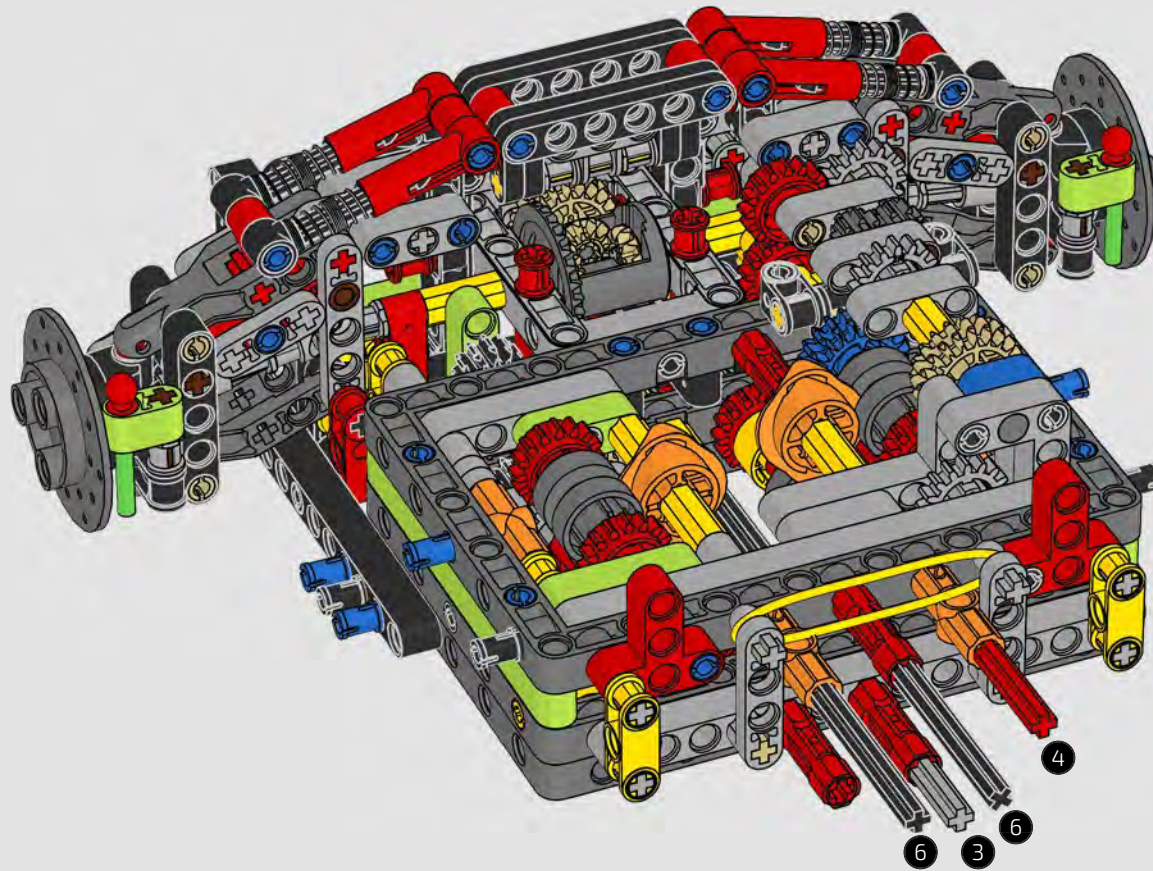

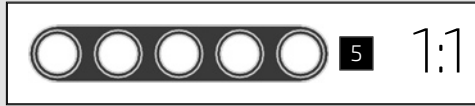
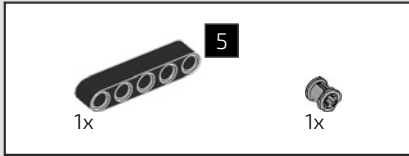

132

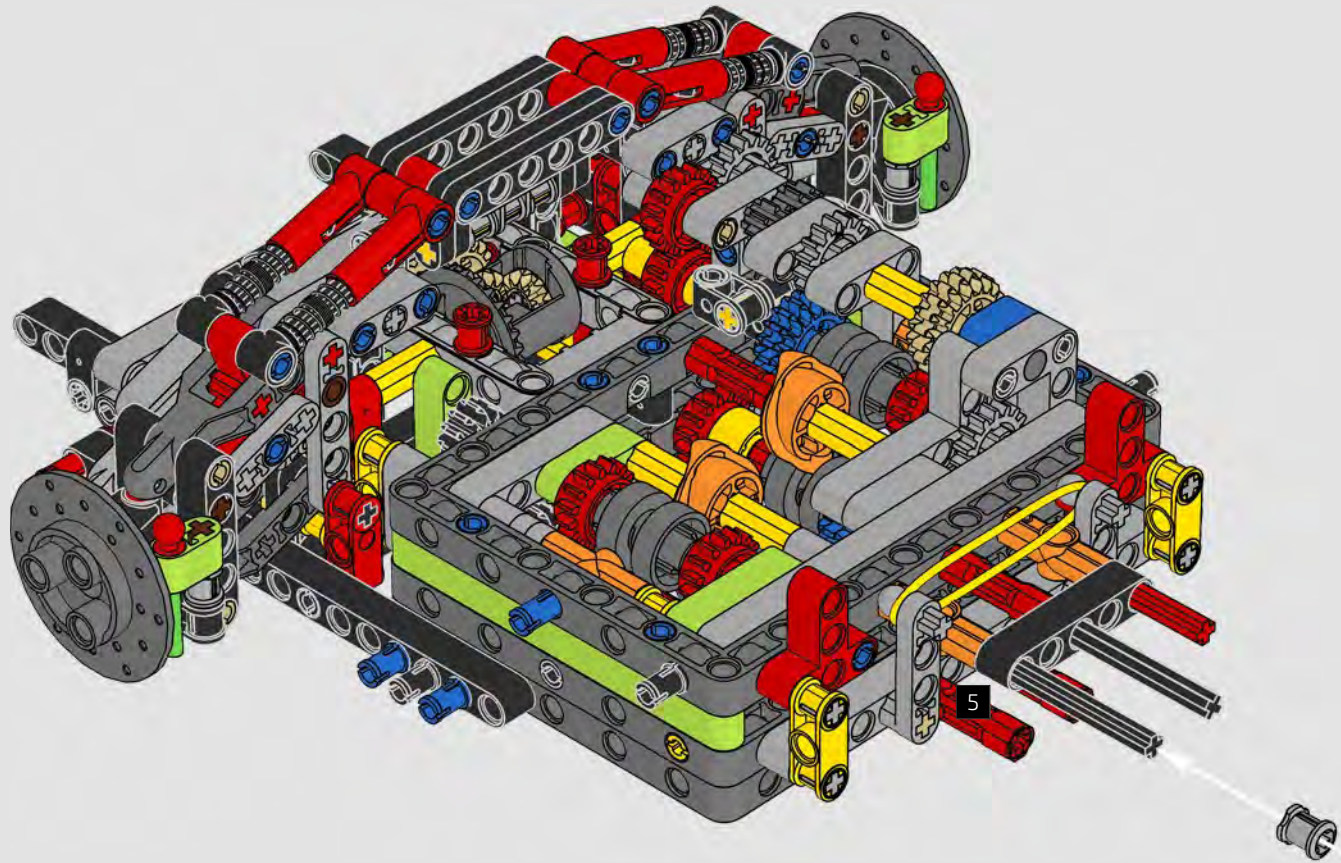



133

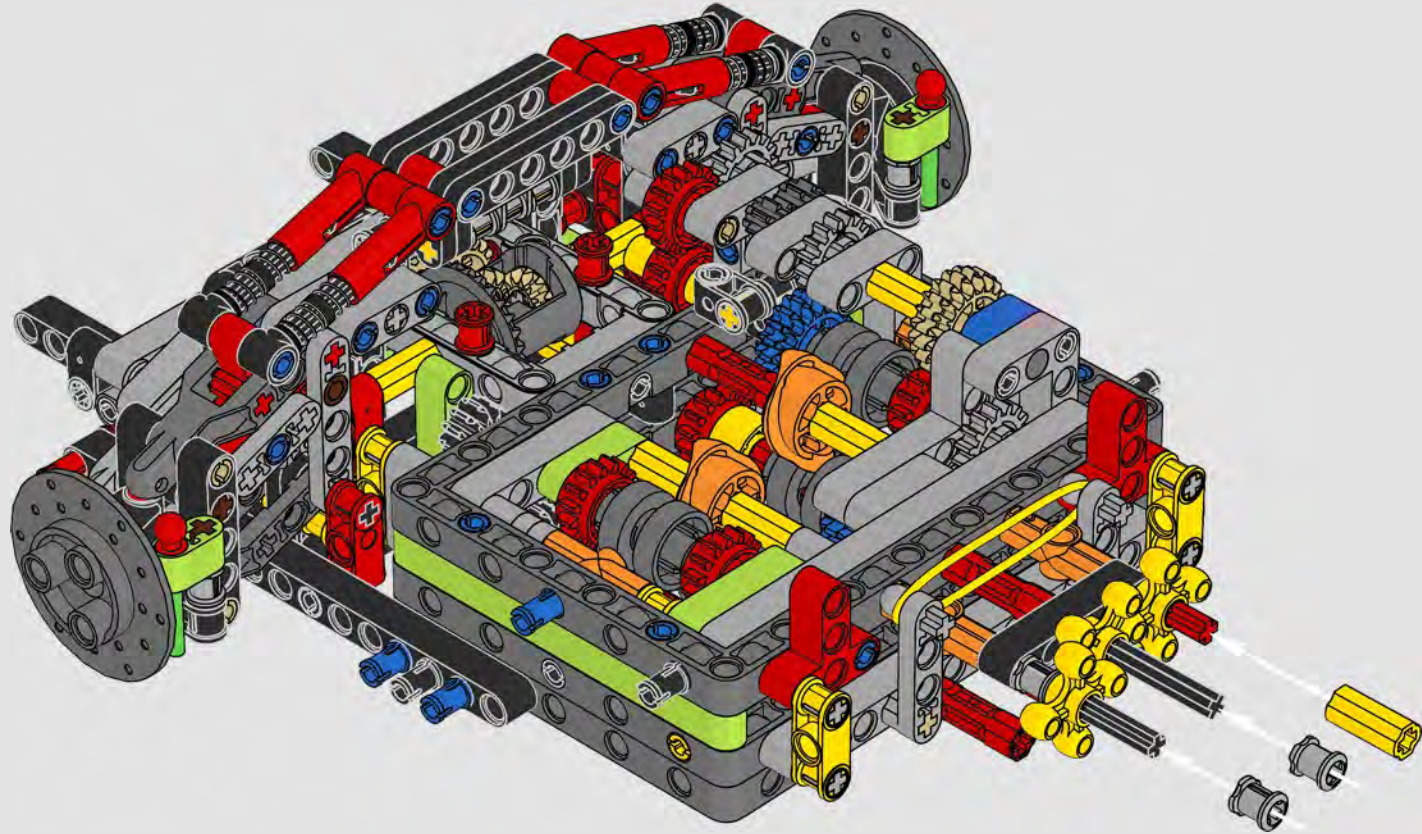

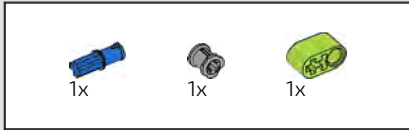

134

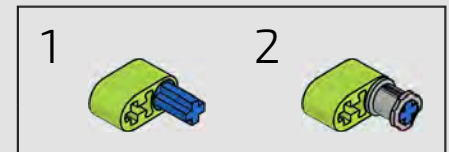
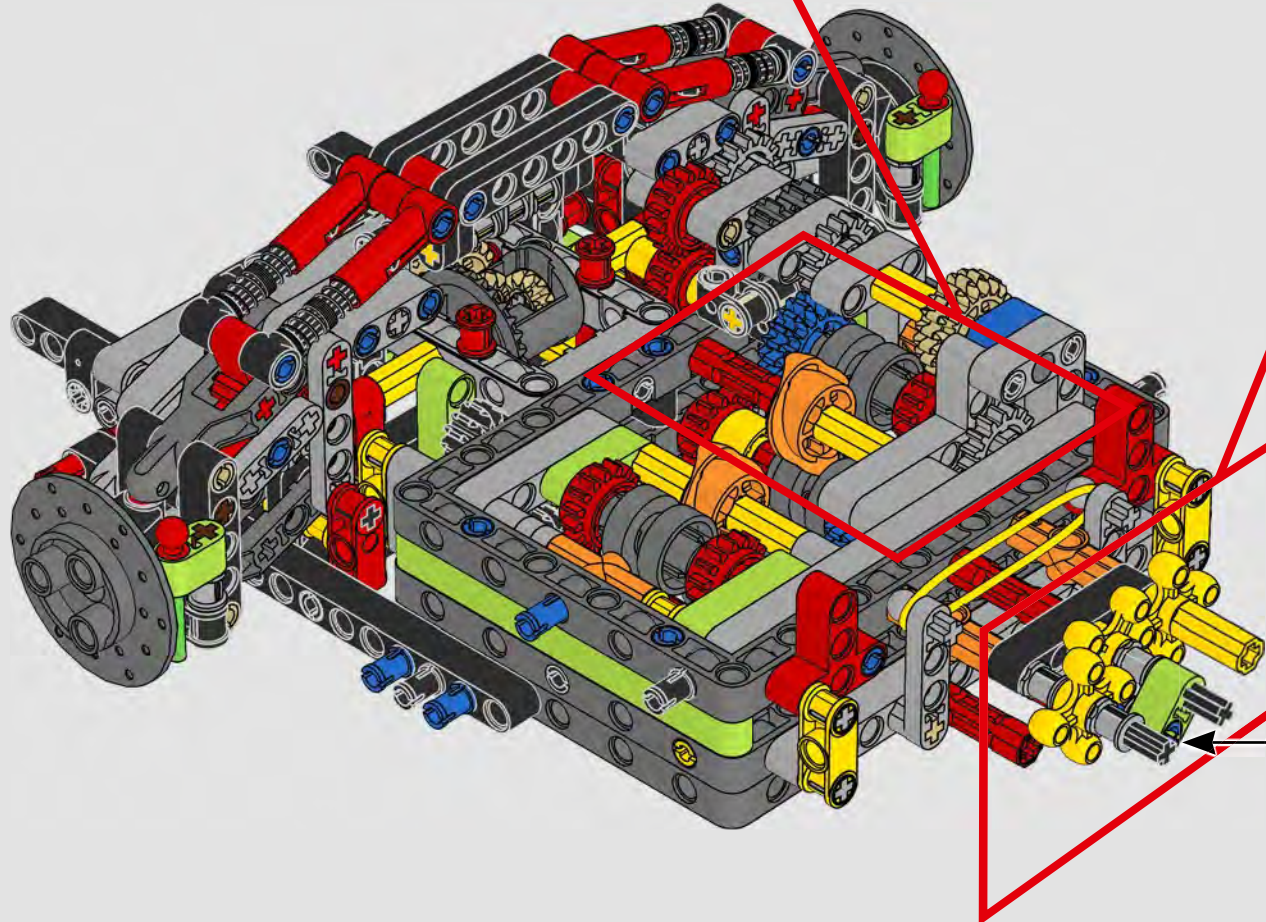
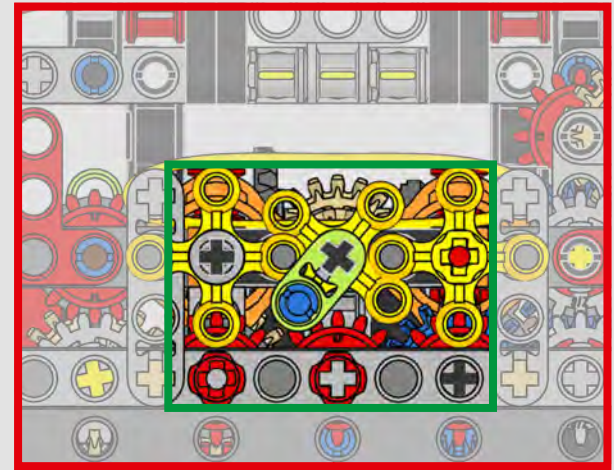
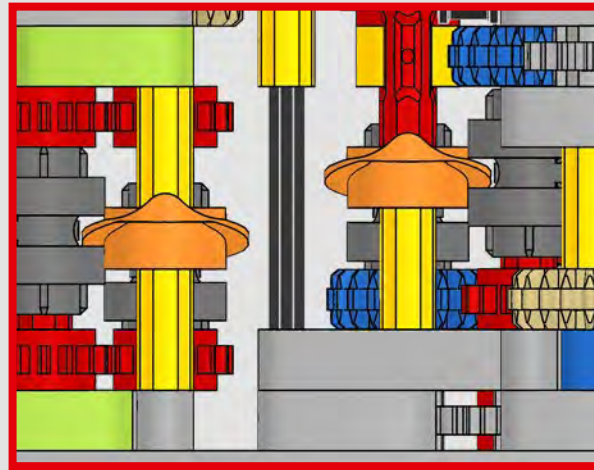

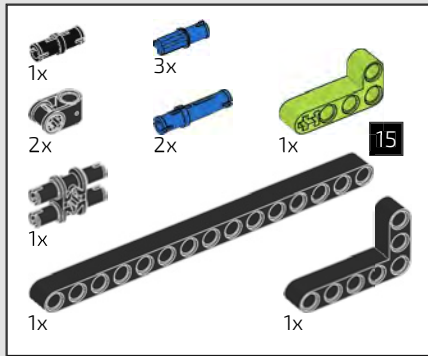

1

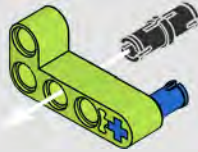

2

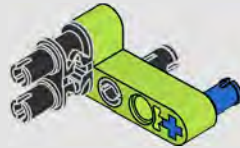

3

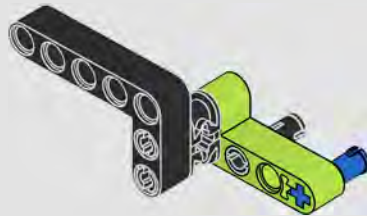

4

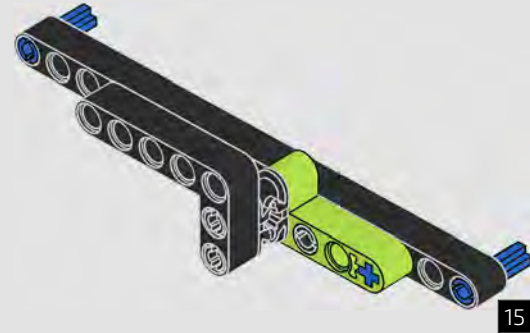

5

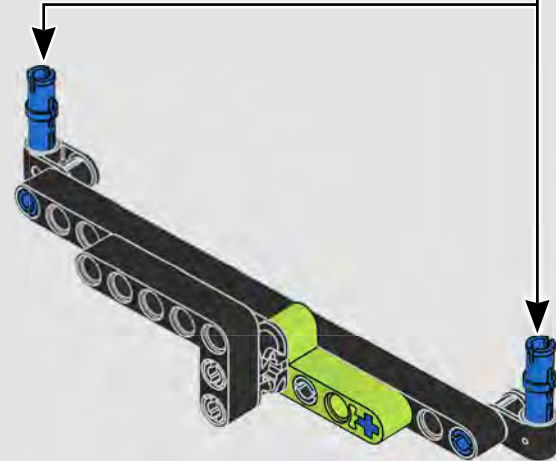

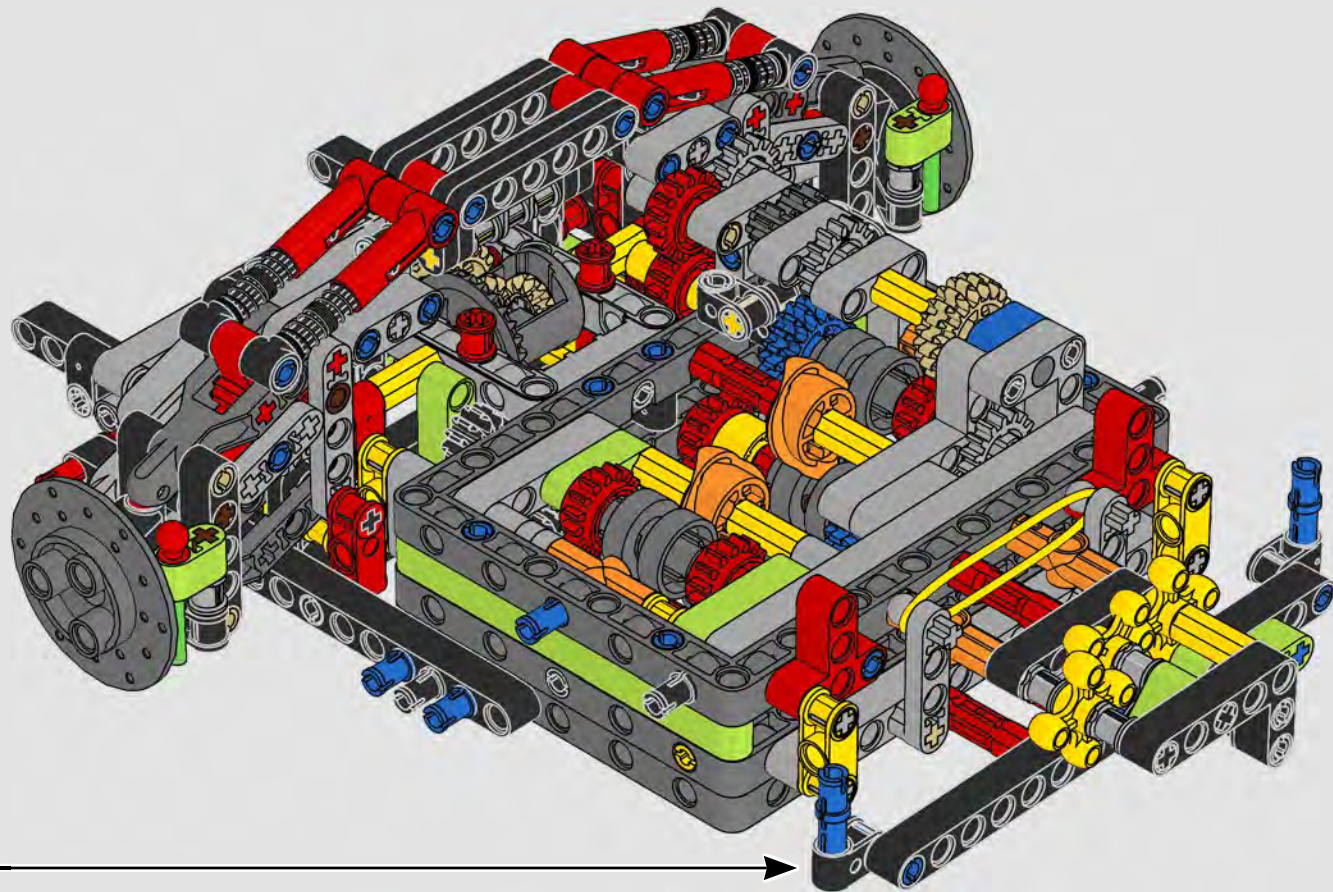

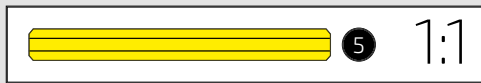
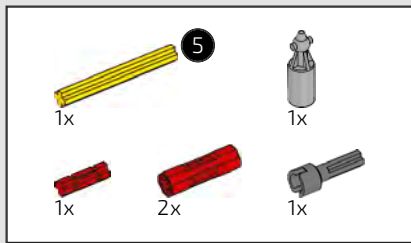

136

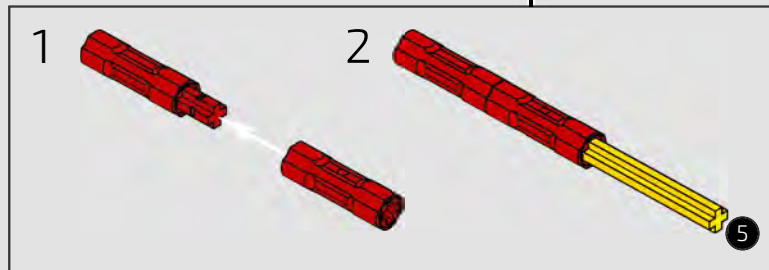
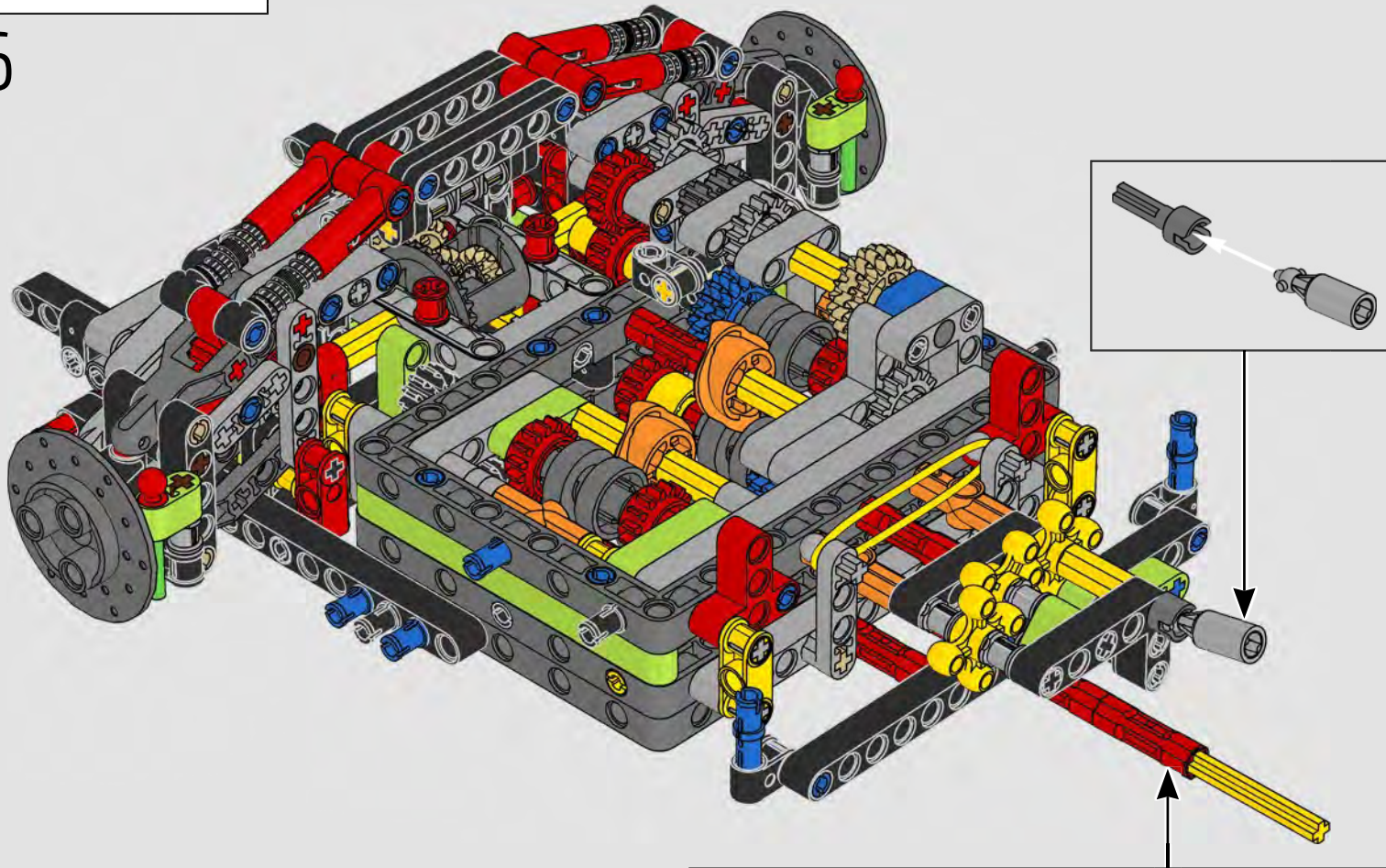

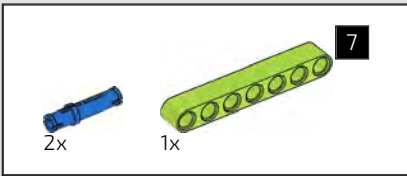
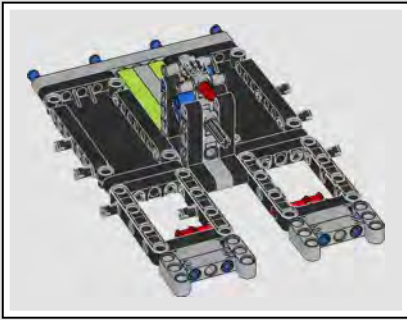

137

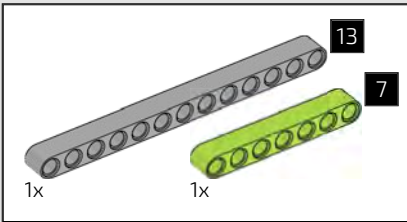
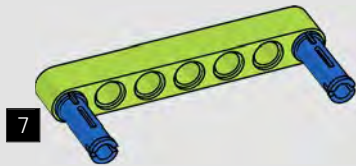

138

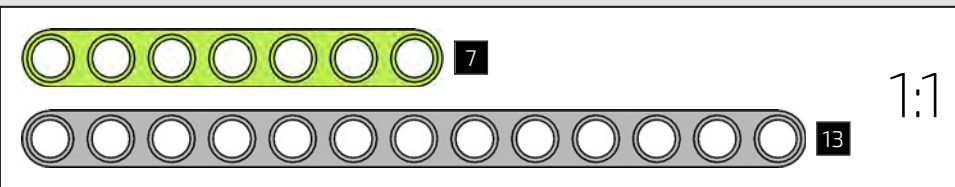
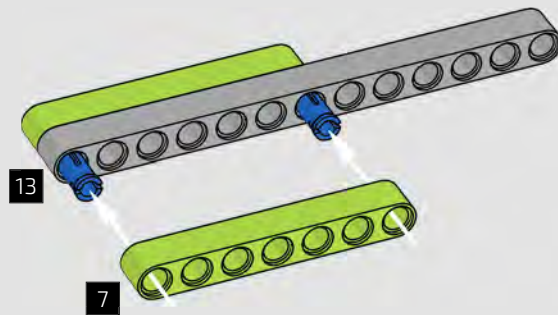

139

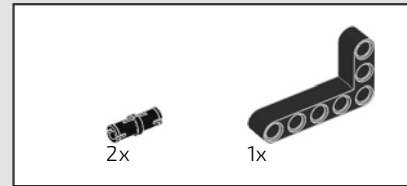
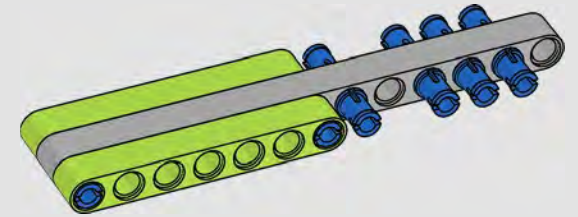

140

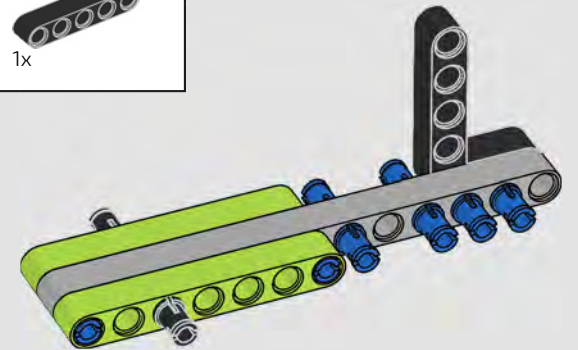

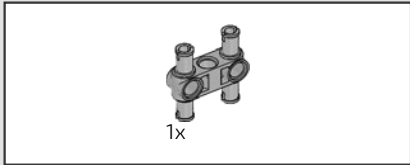

141

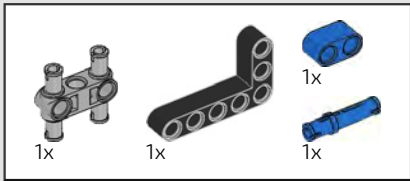
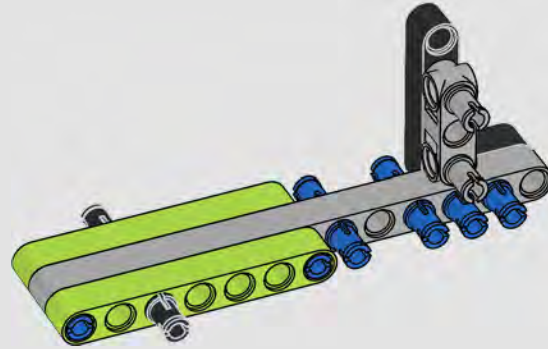

142

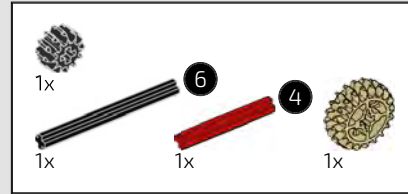
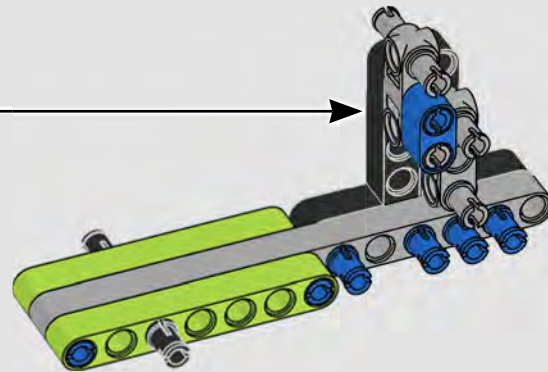
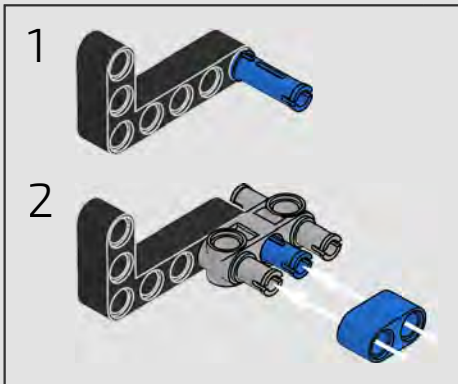

143

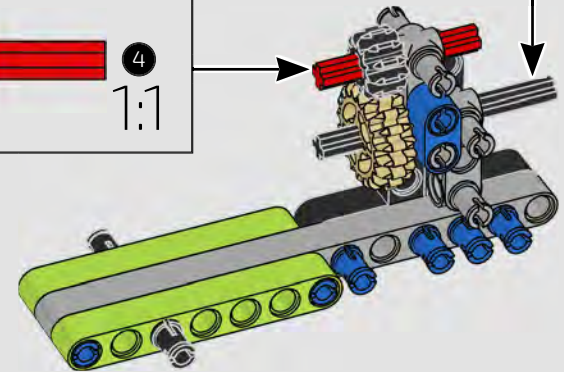

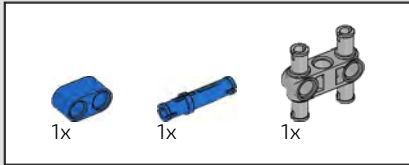

144

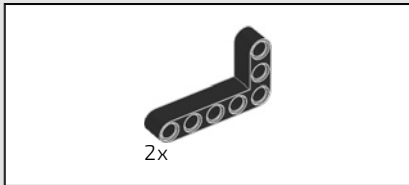
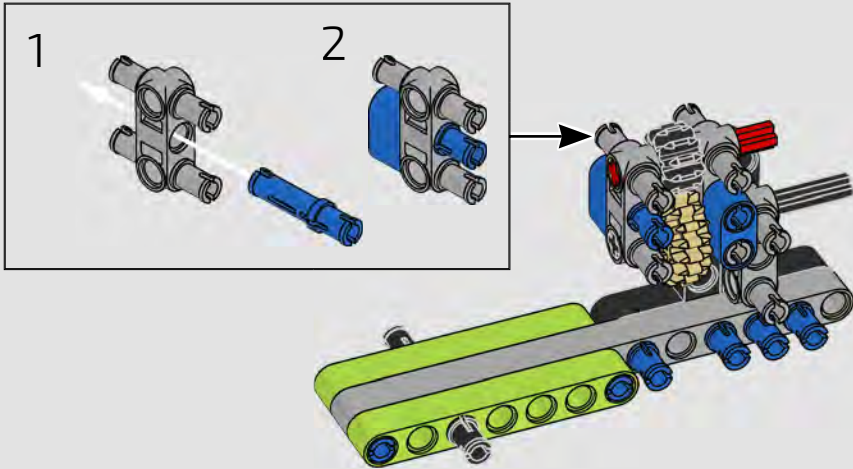

145

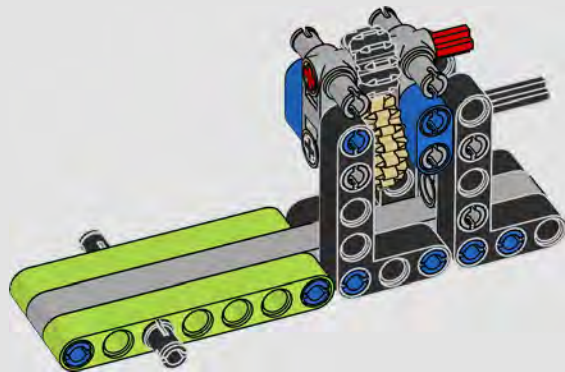

146

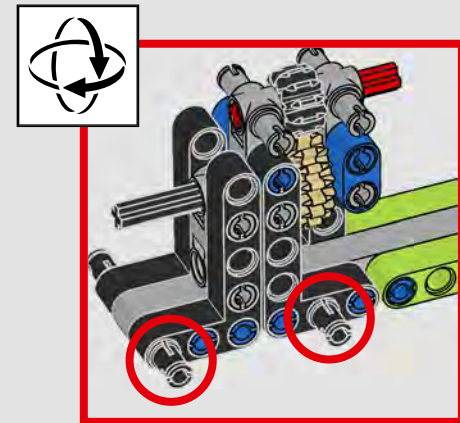
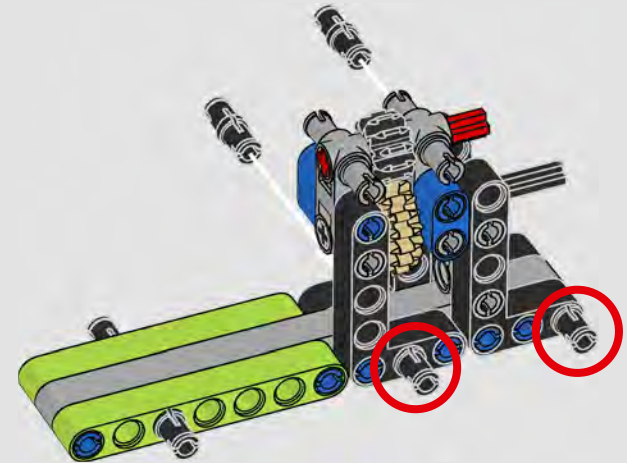

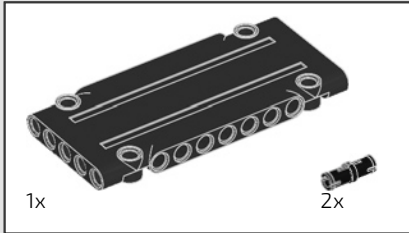
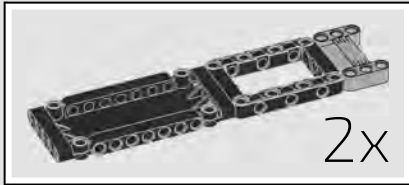

147

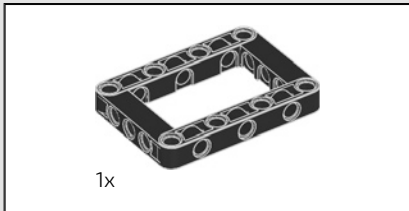
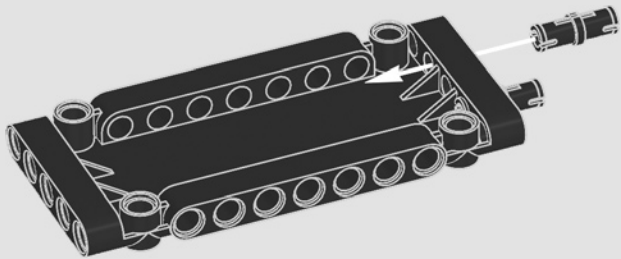

148

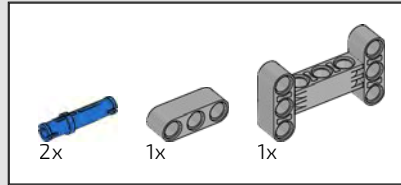
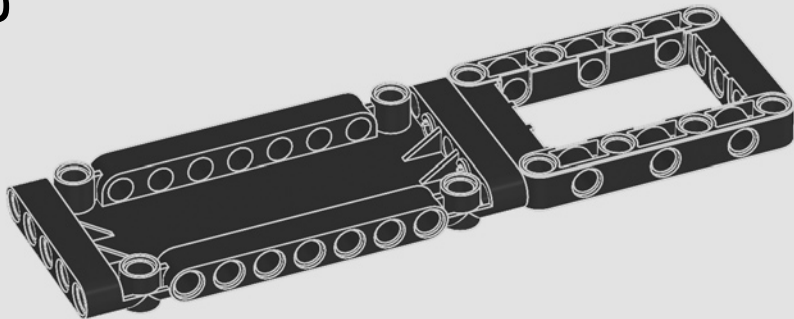

149

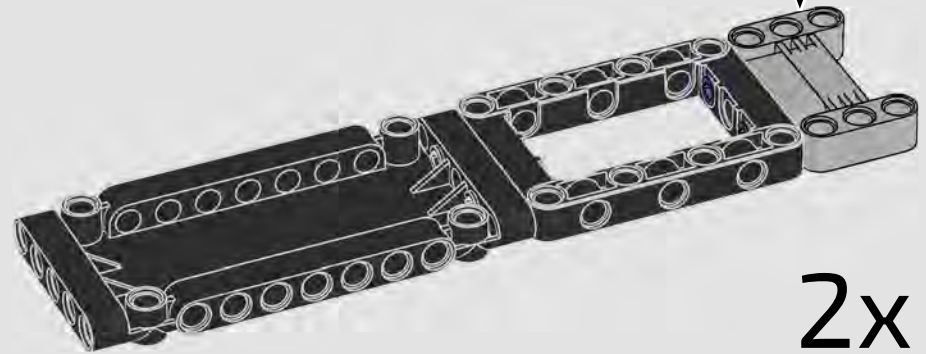
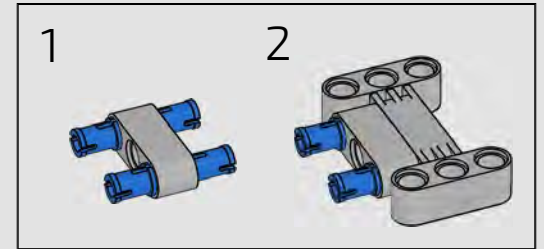

150

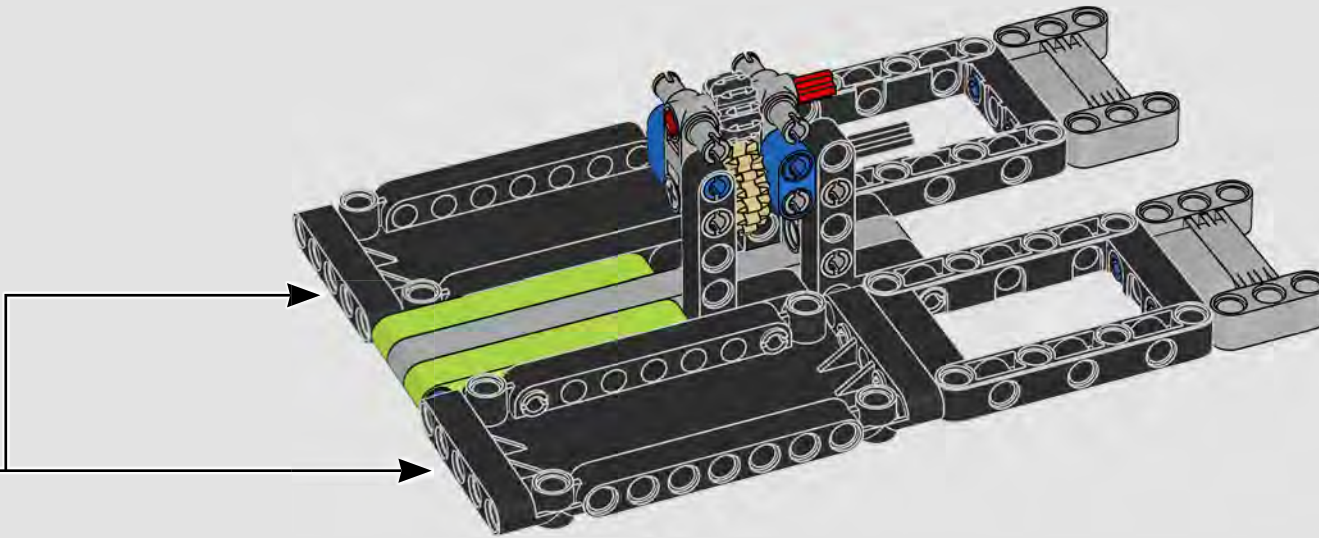

151

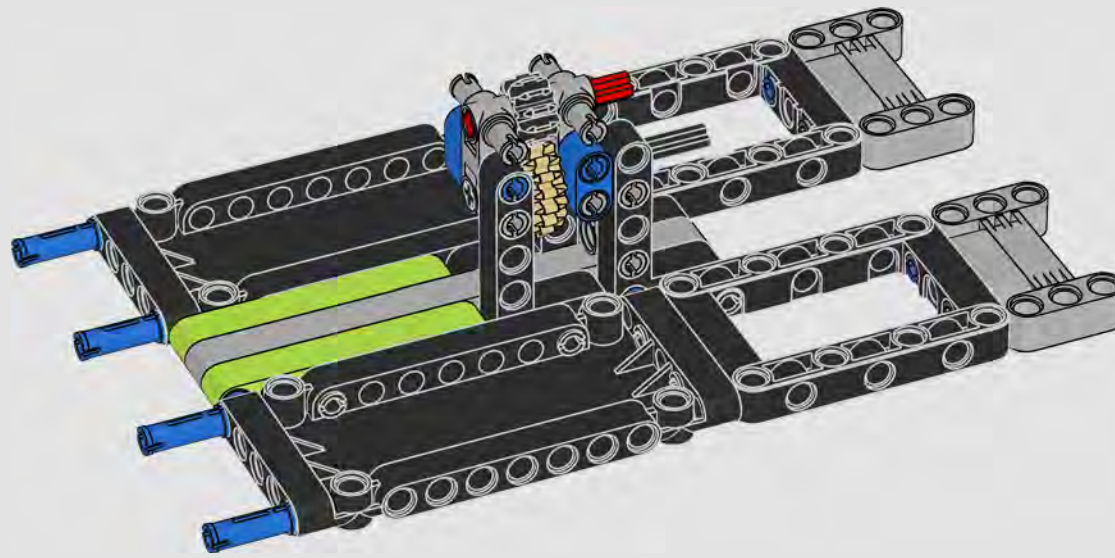

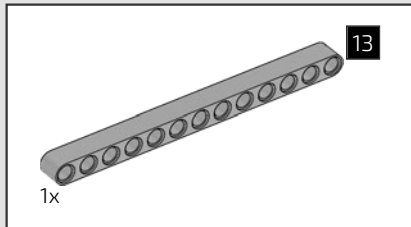

152

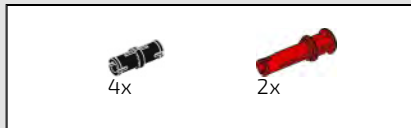
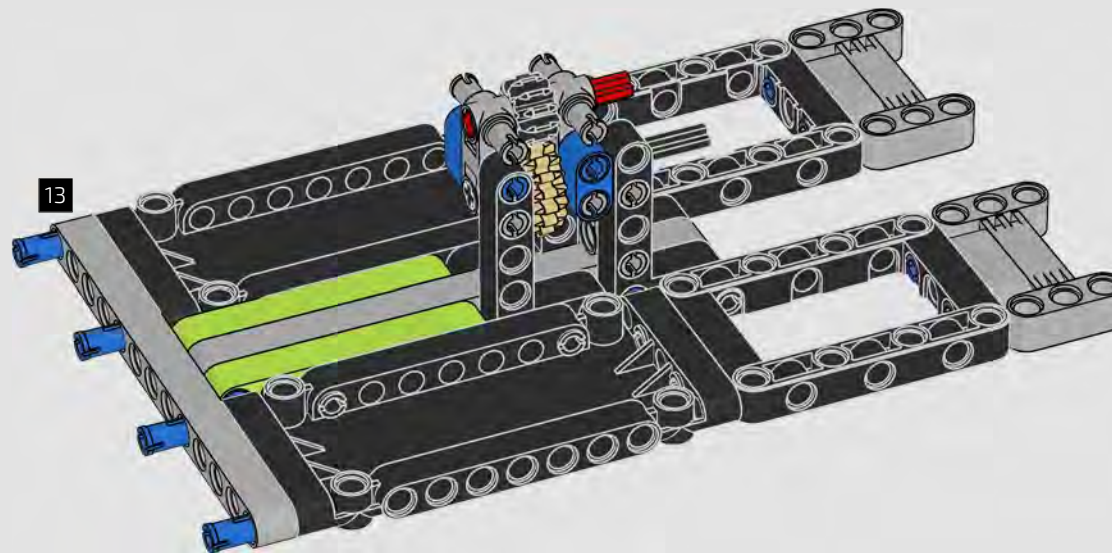

153

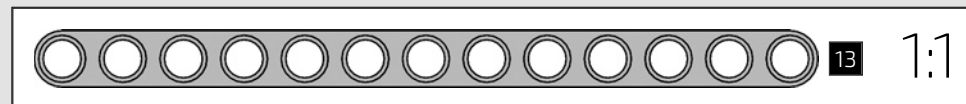
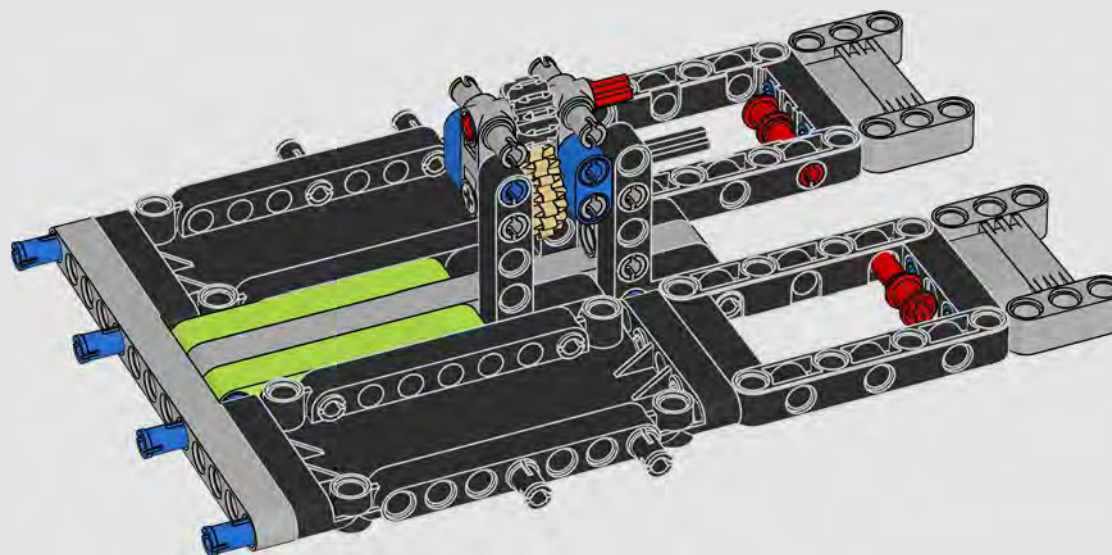



154

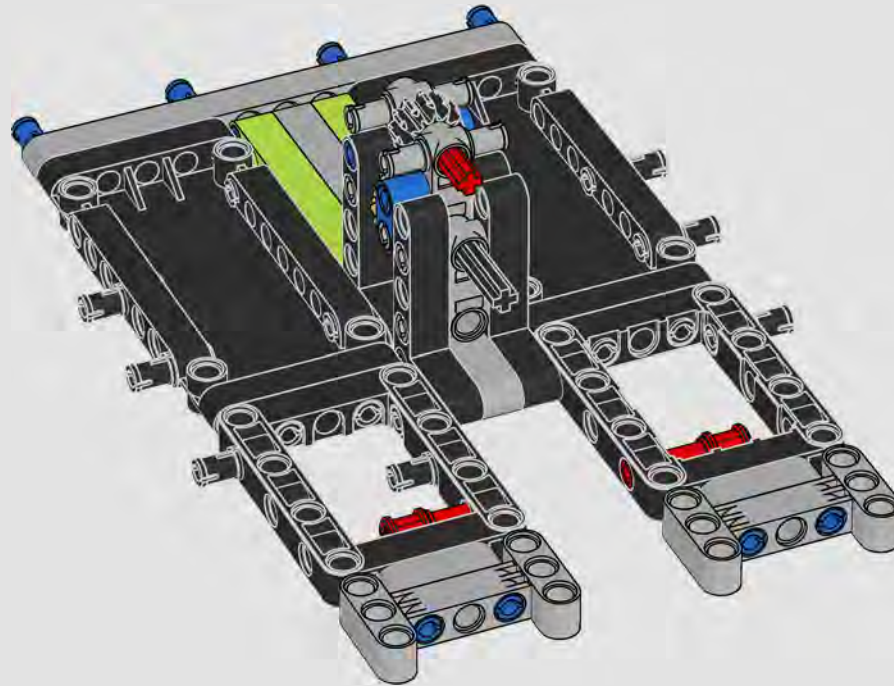
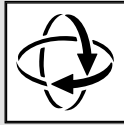

155

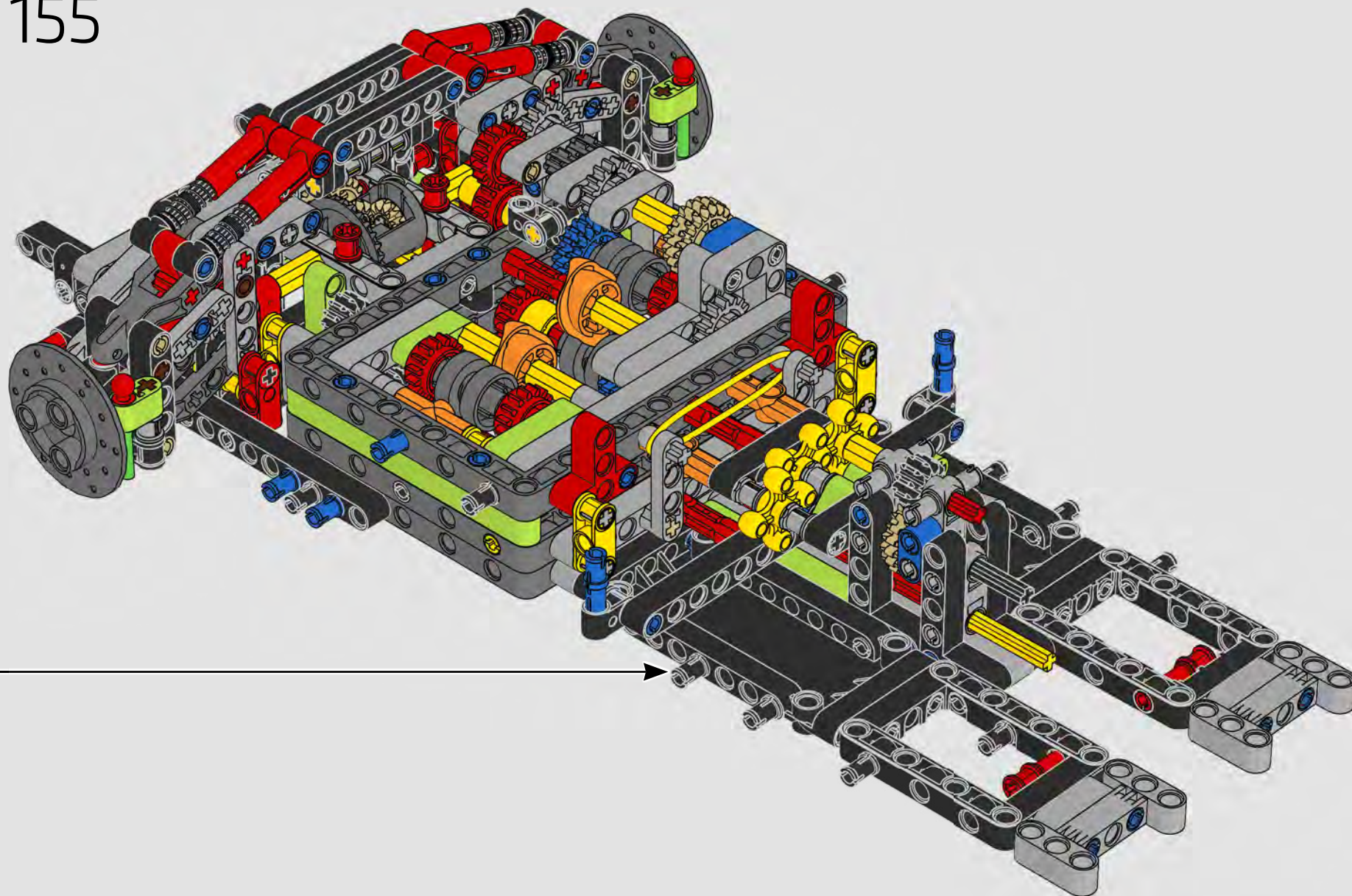

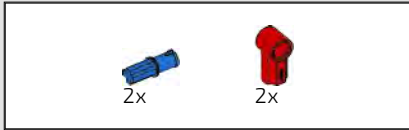

156

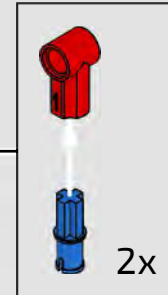
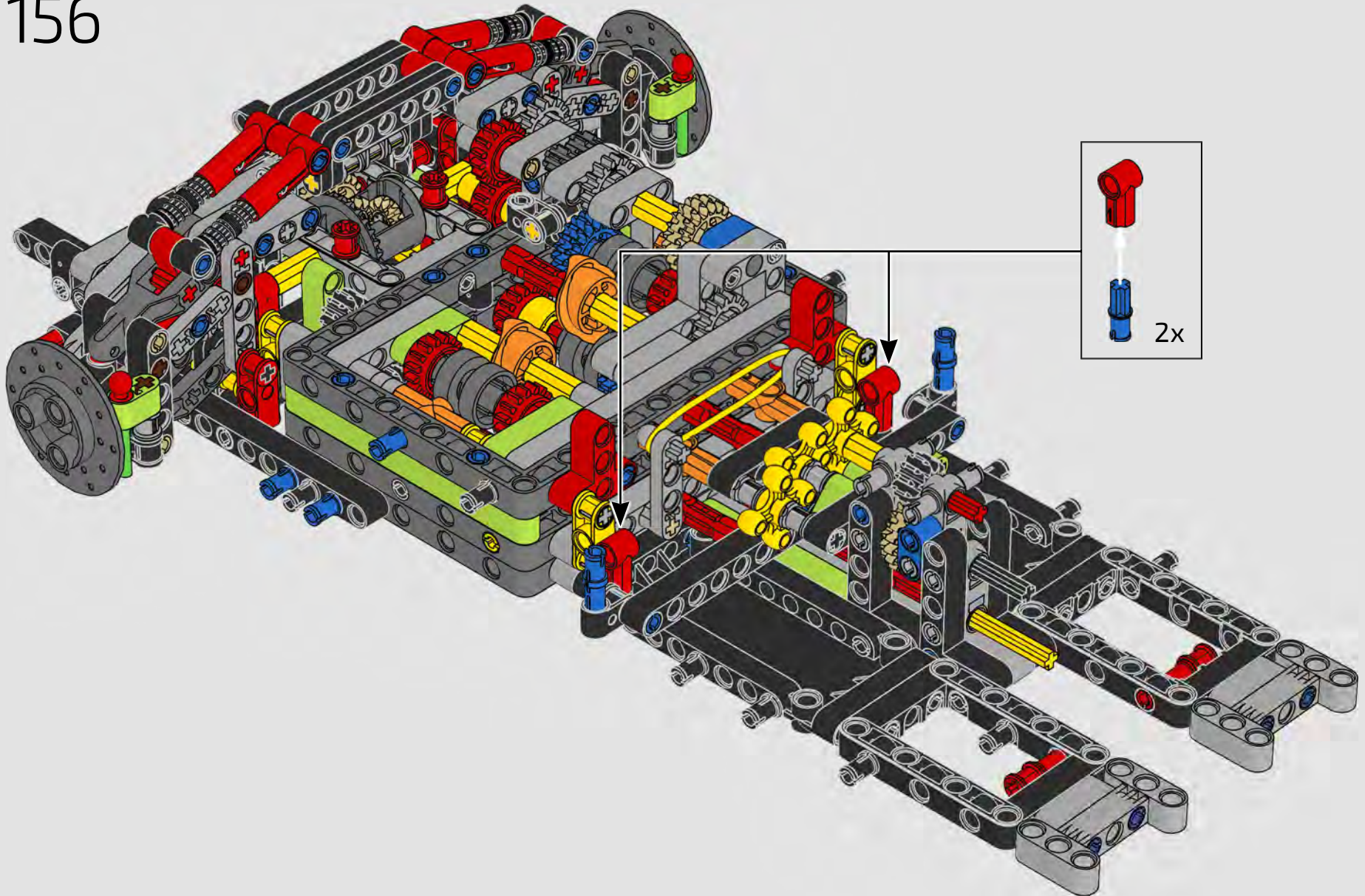

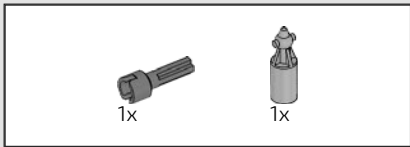

157

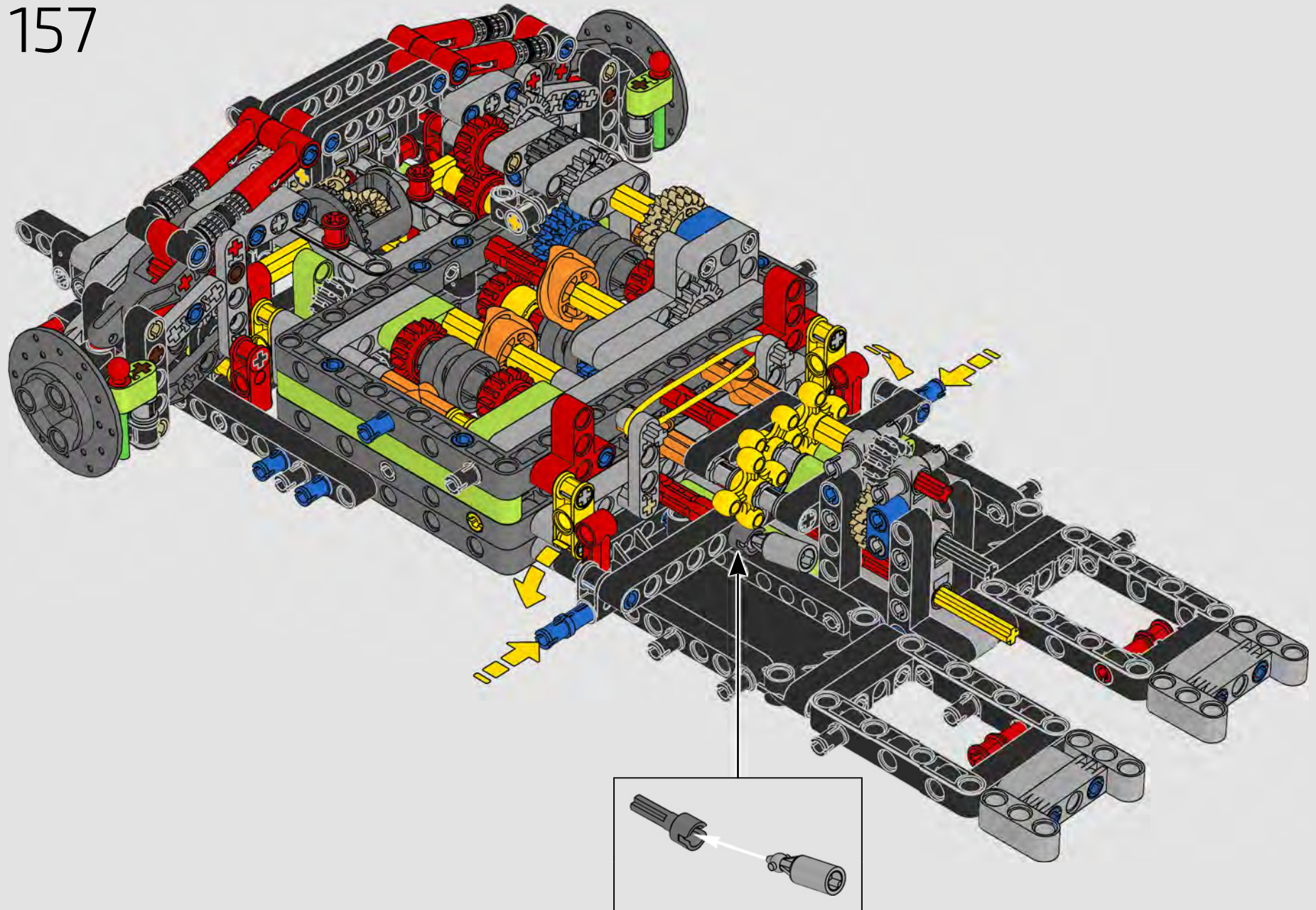



158

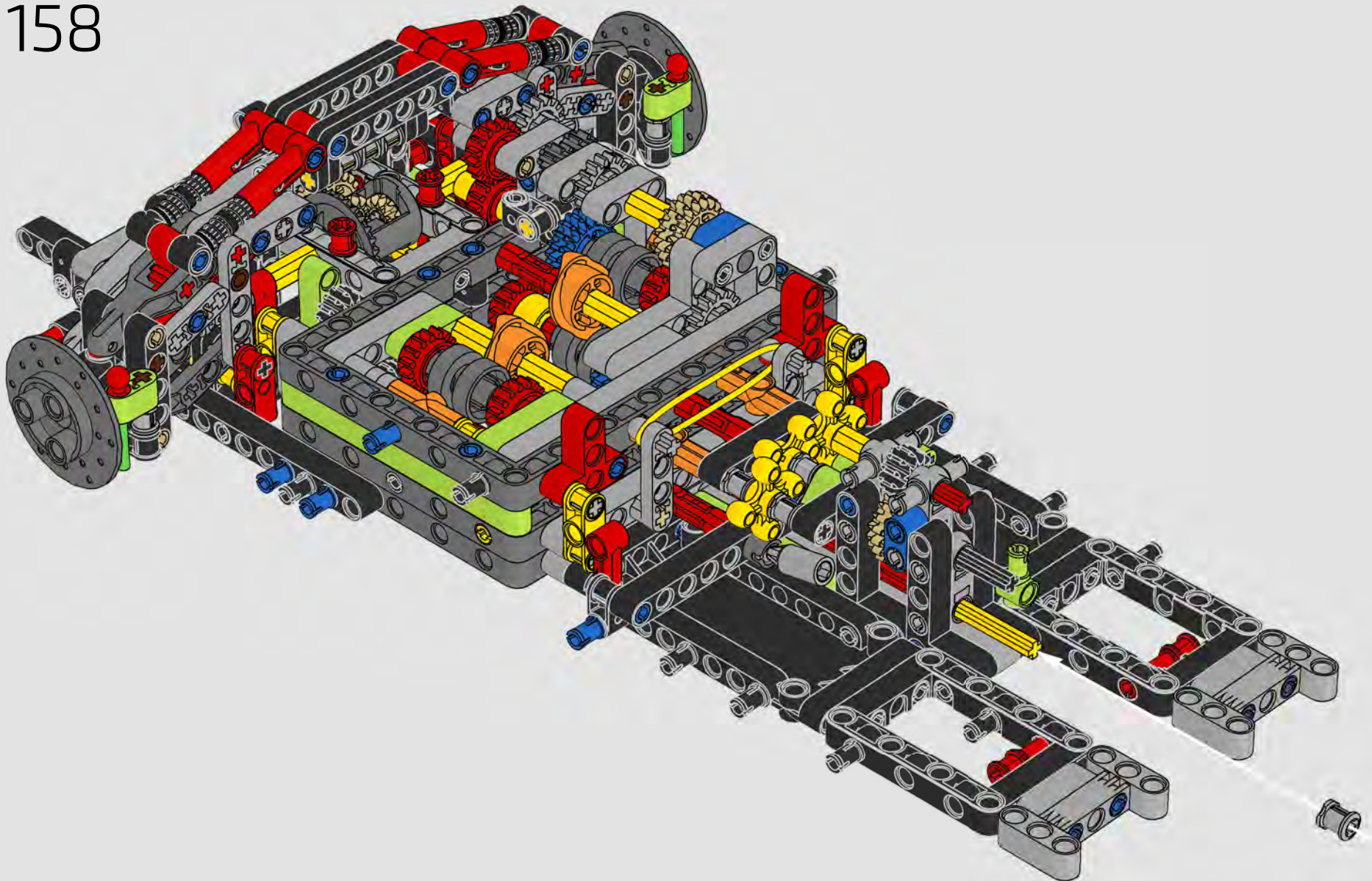

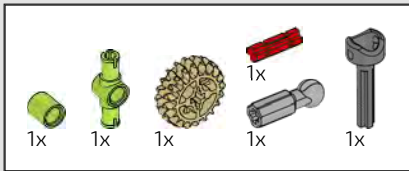

159

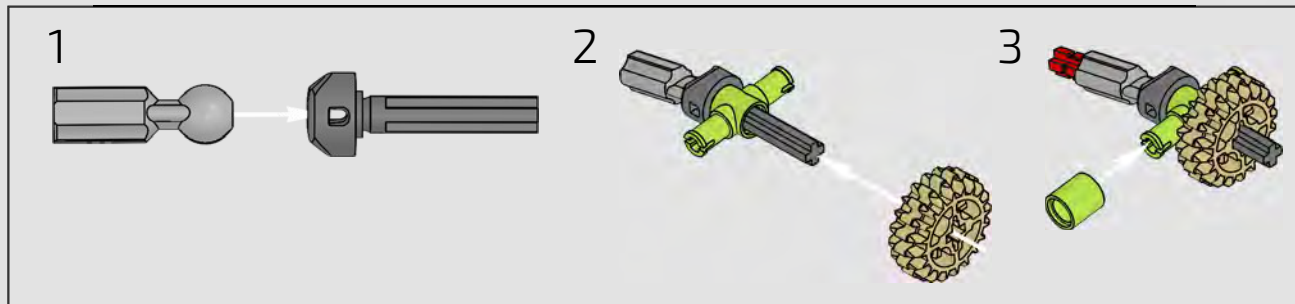
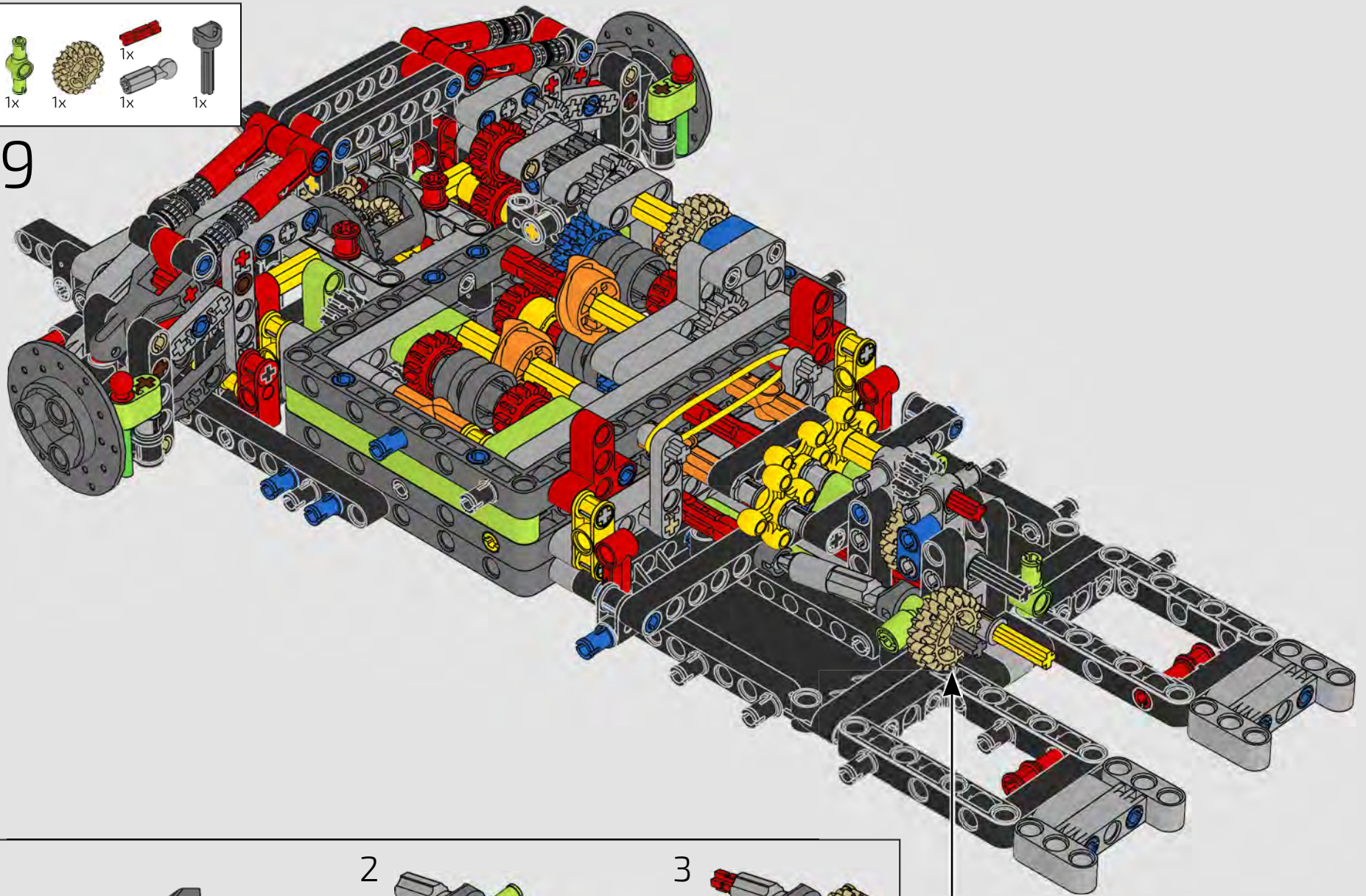

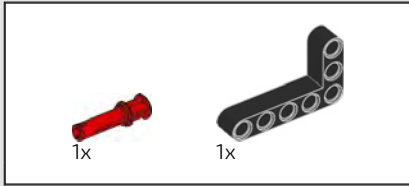

160

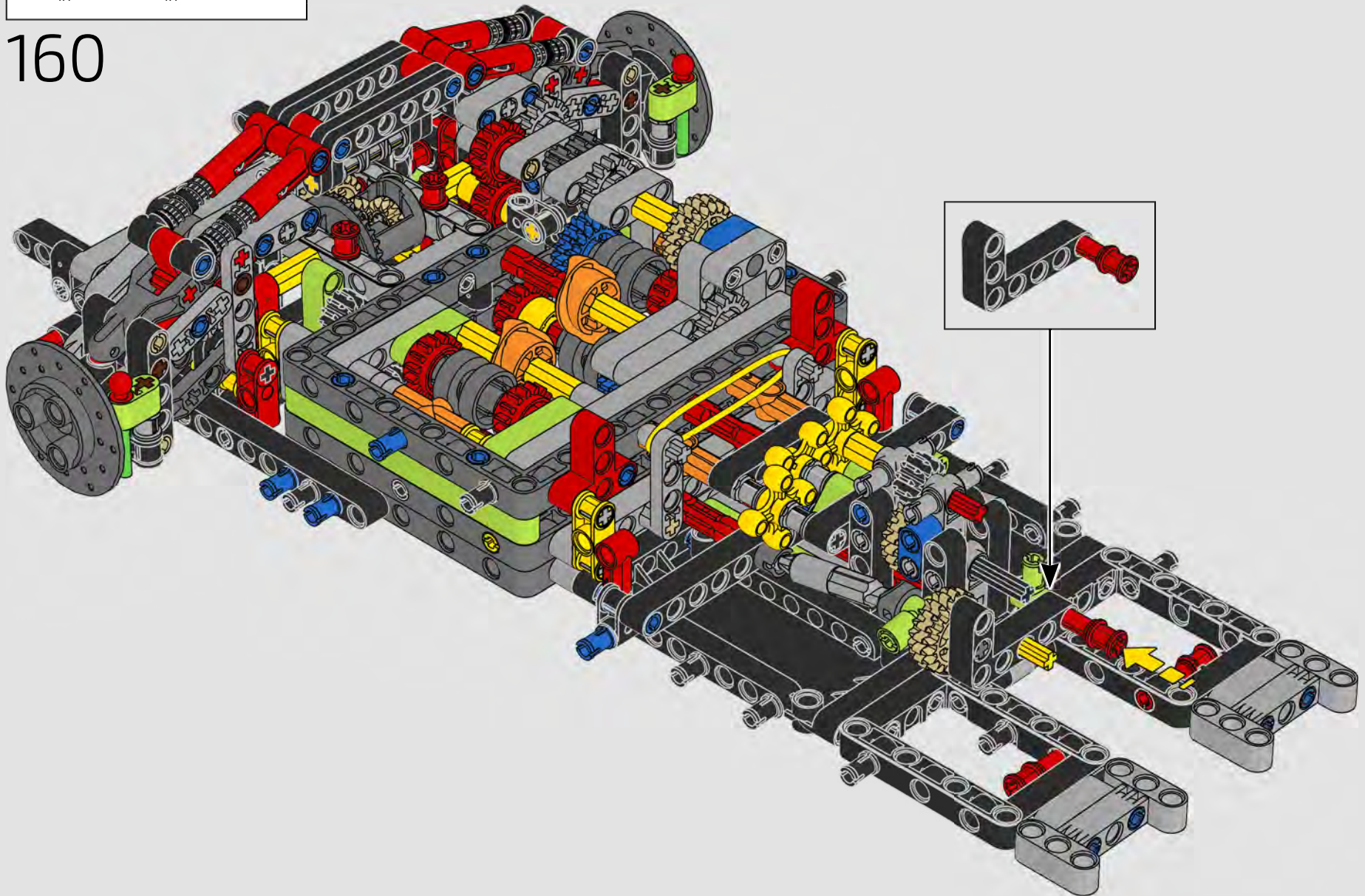



161

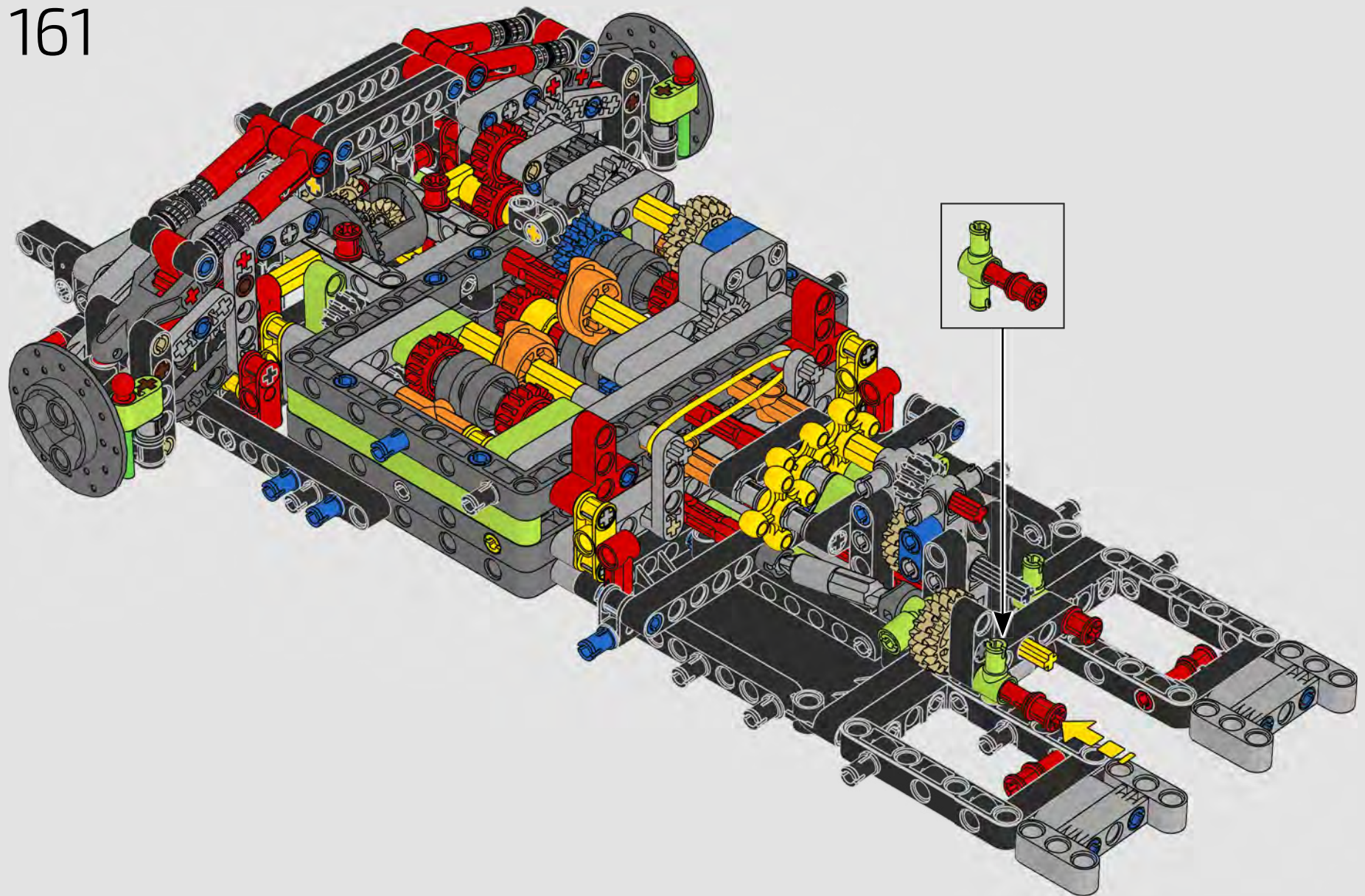

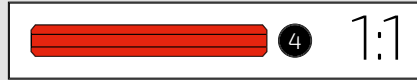
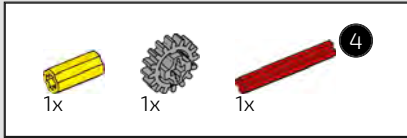

162

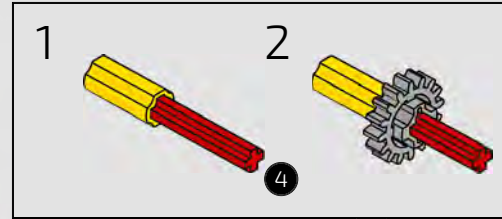
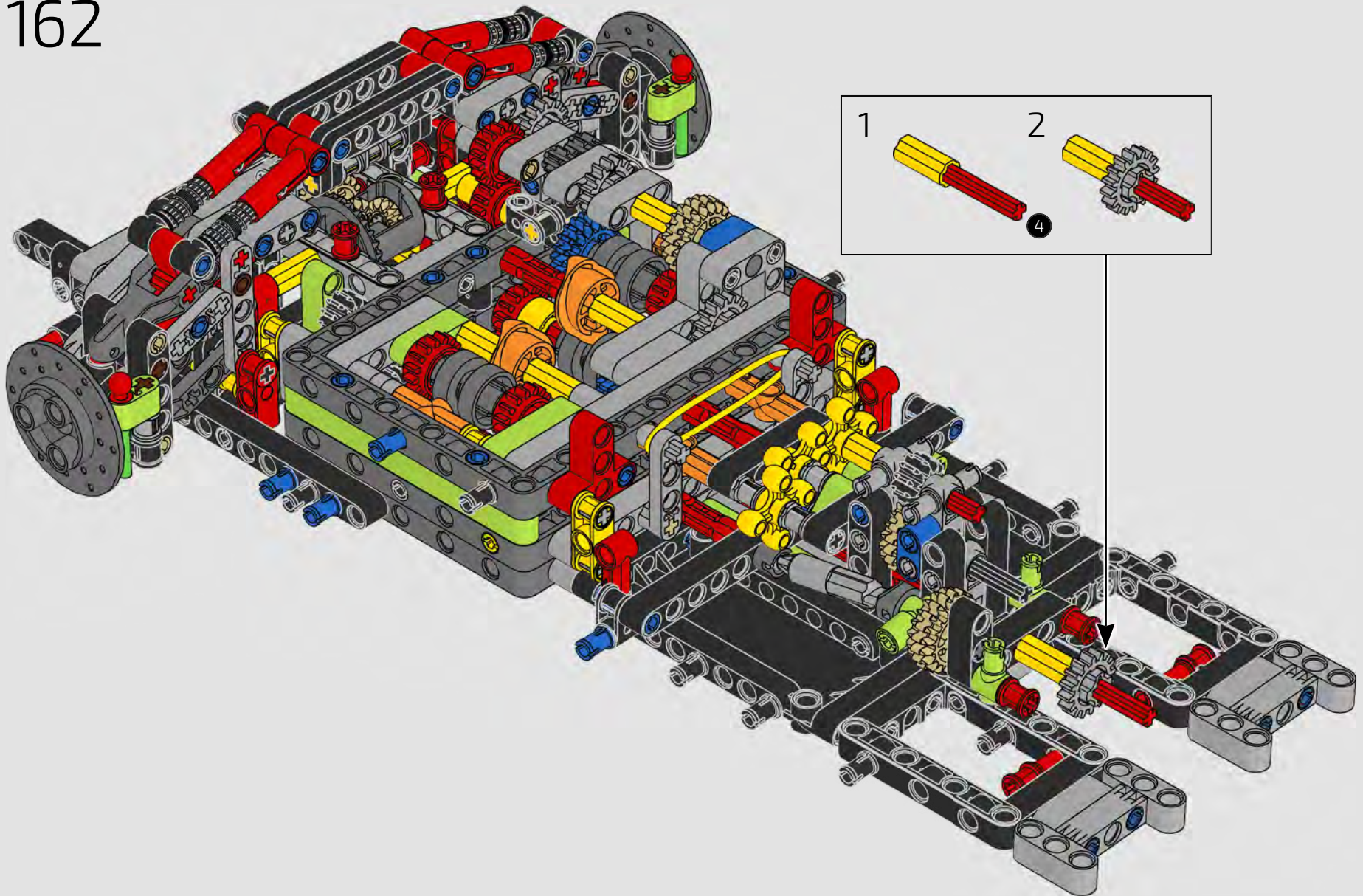

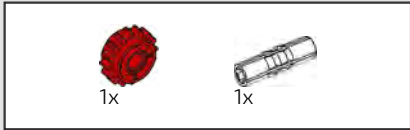

163

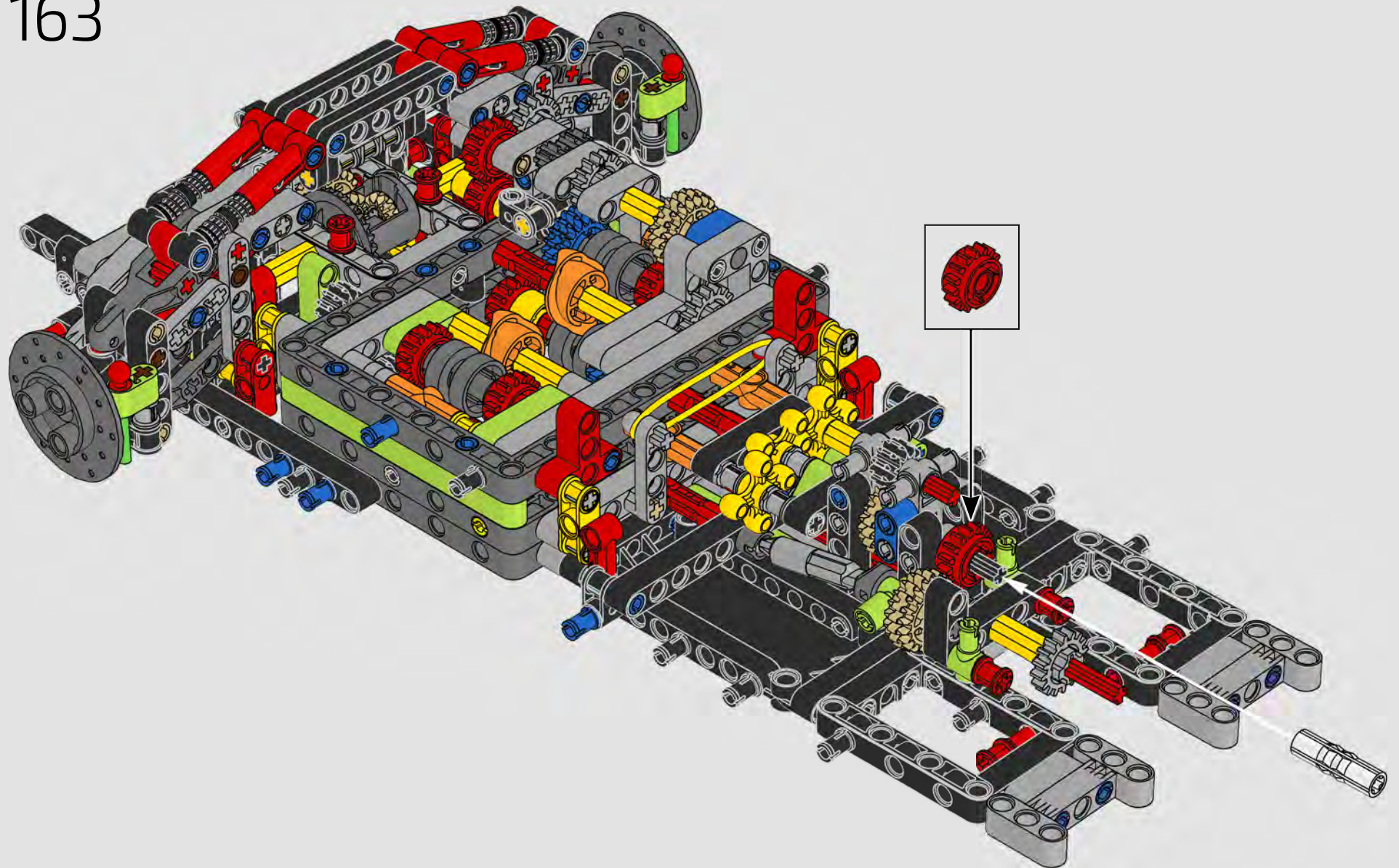

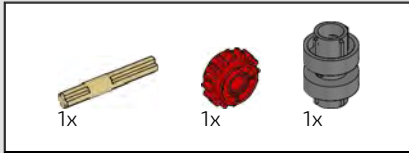

164

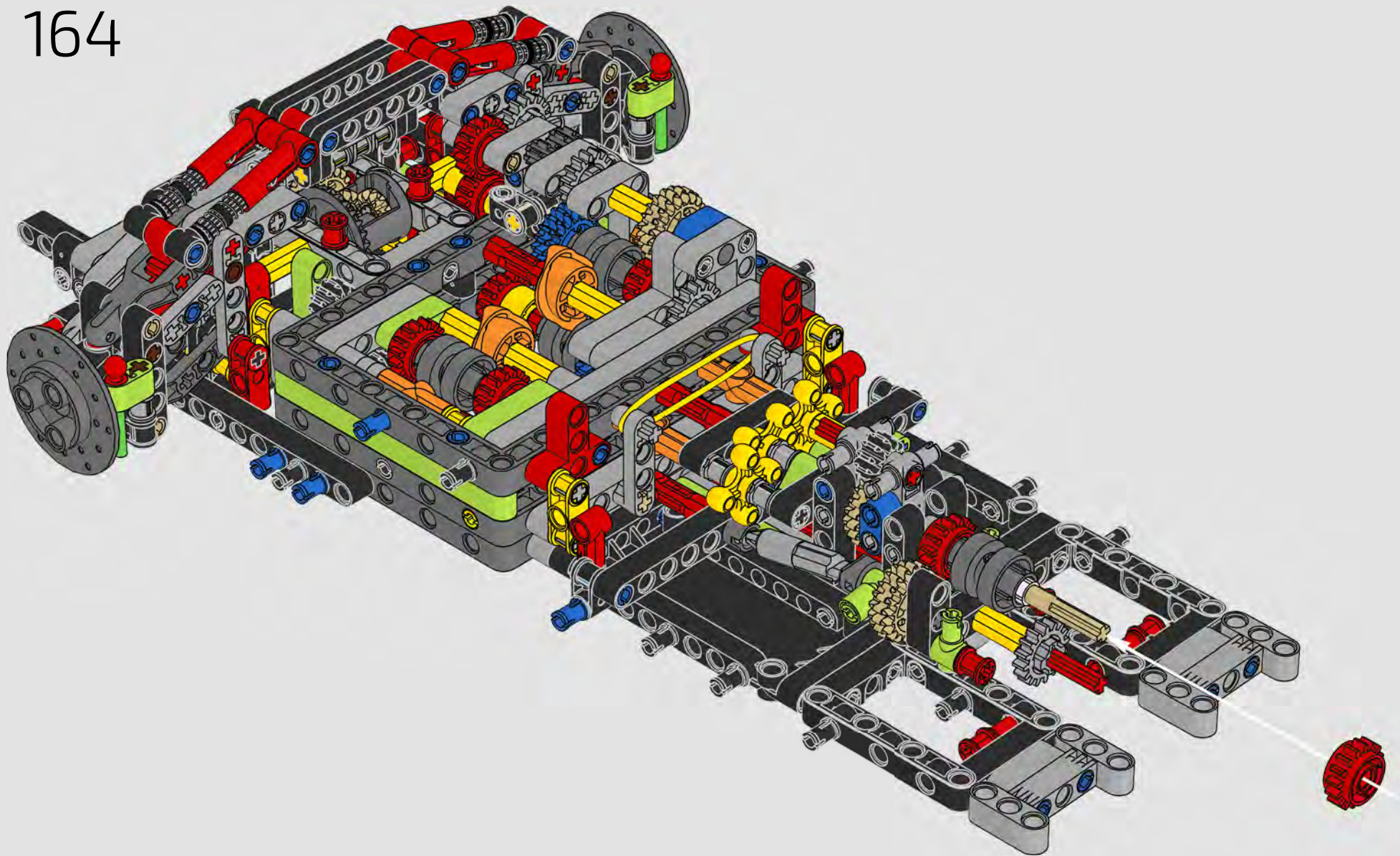

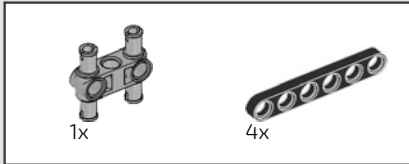

165

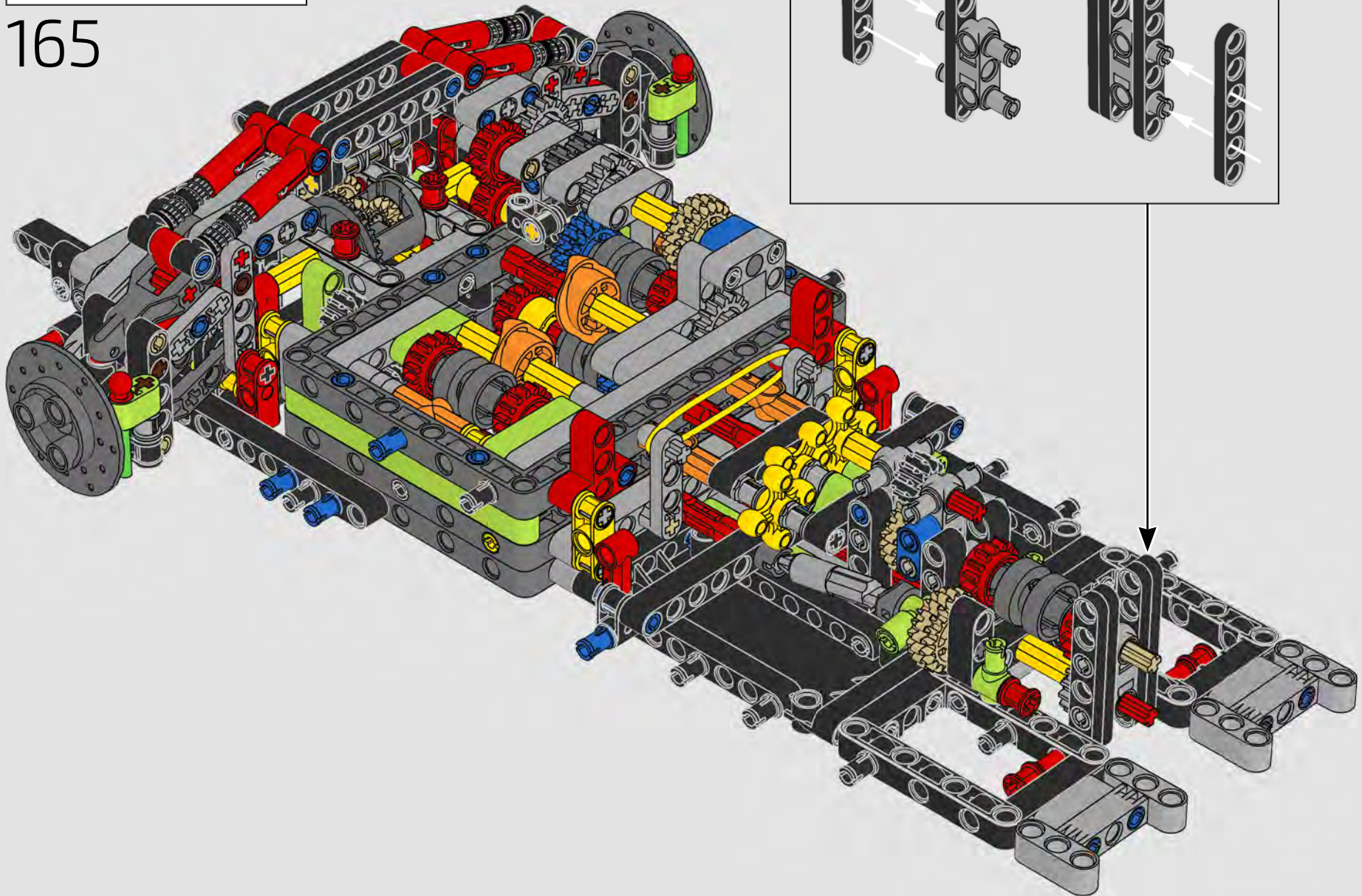

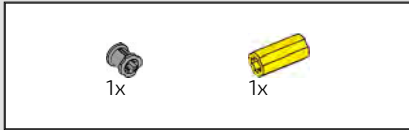

166

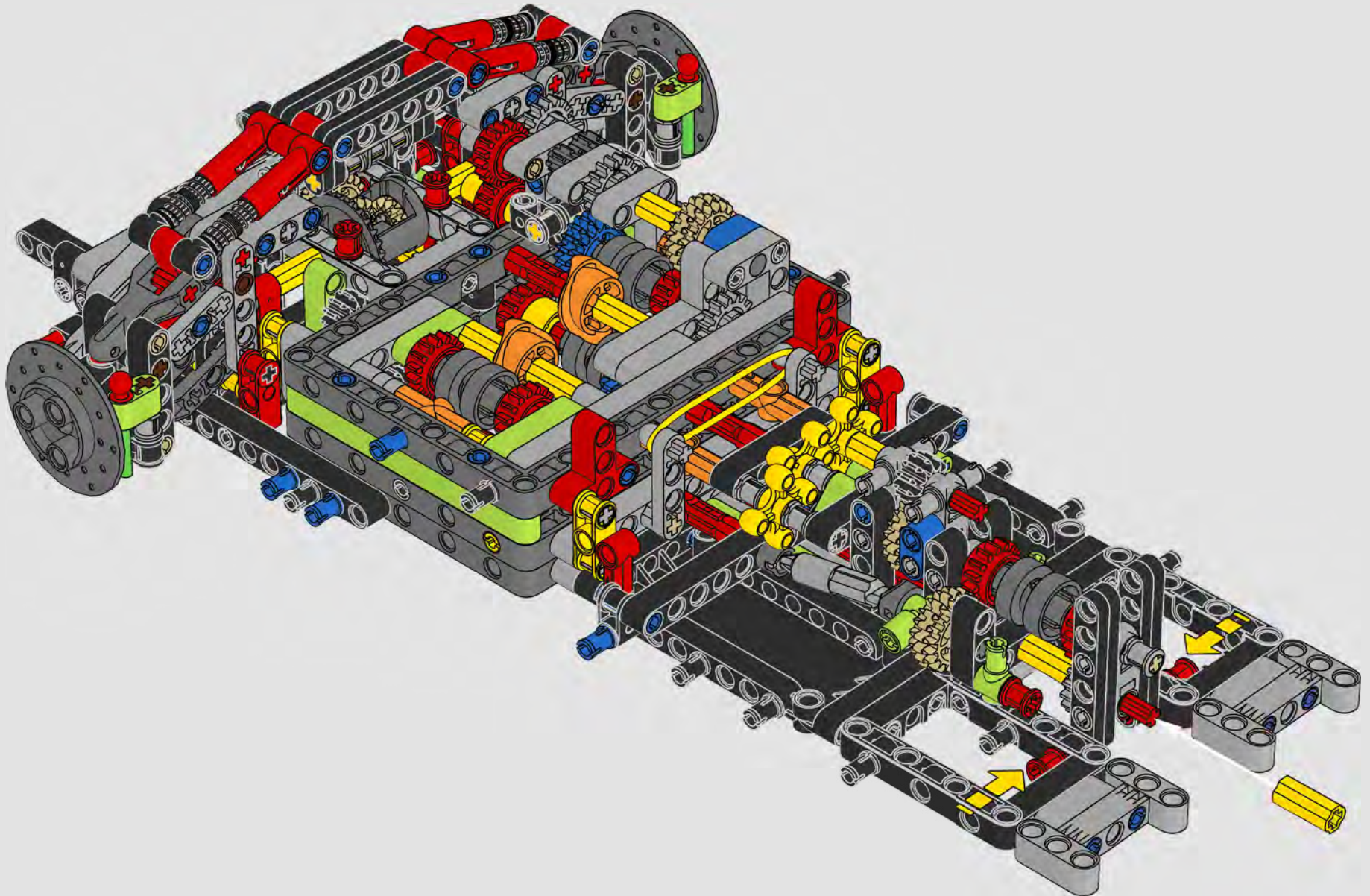

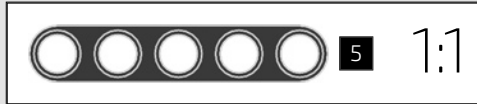
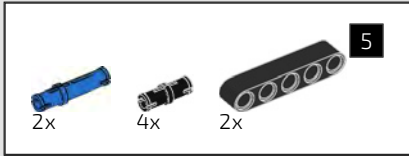

167

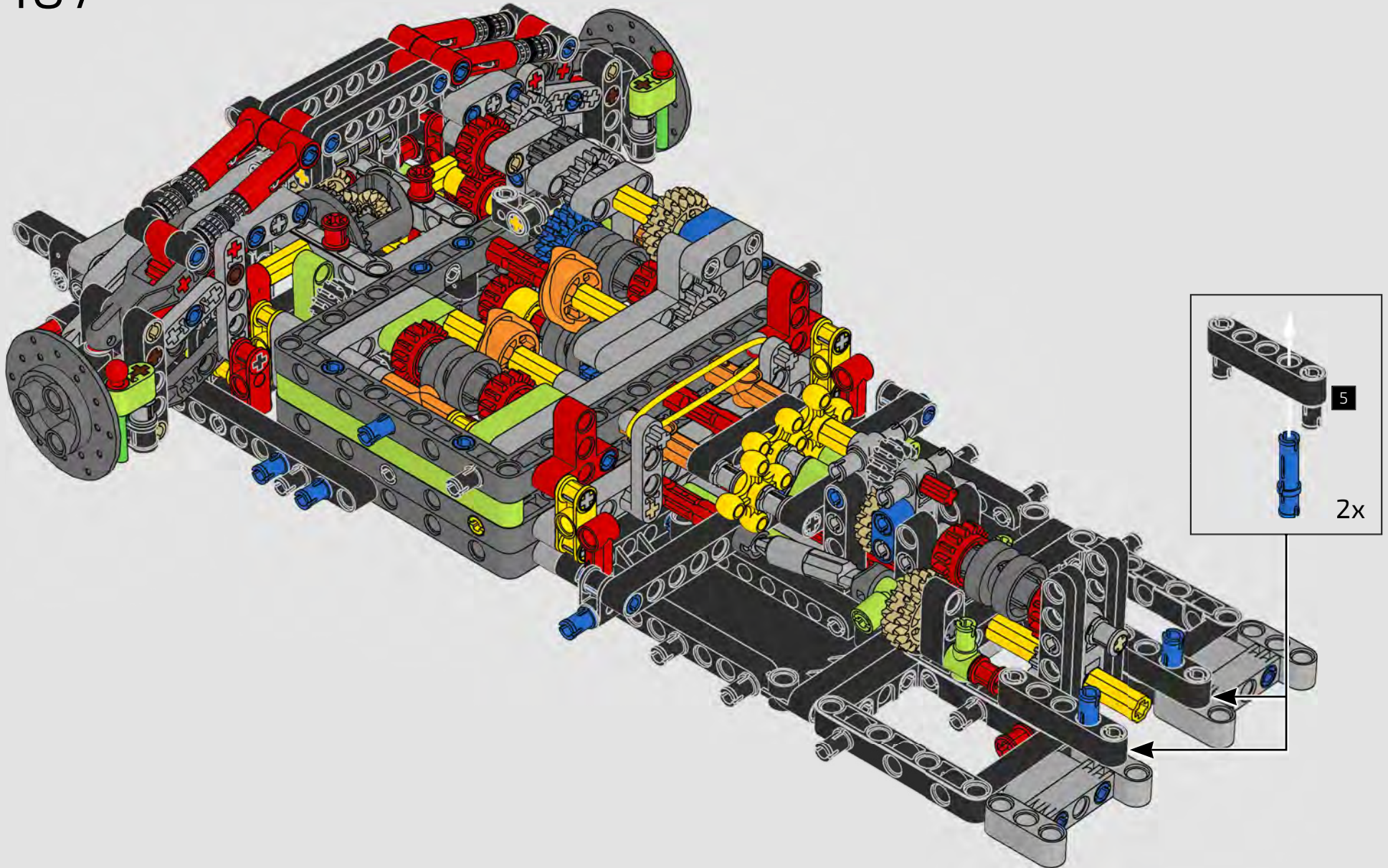

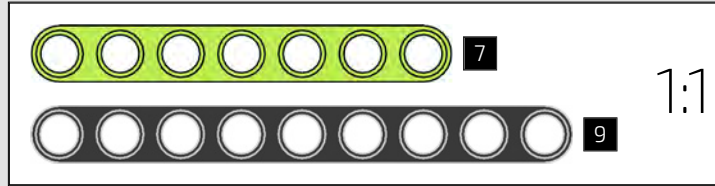
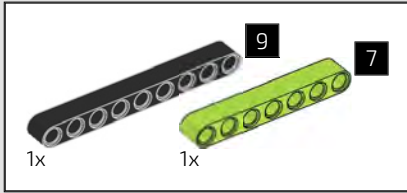

168

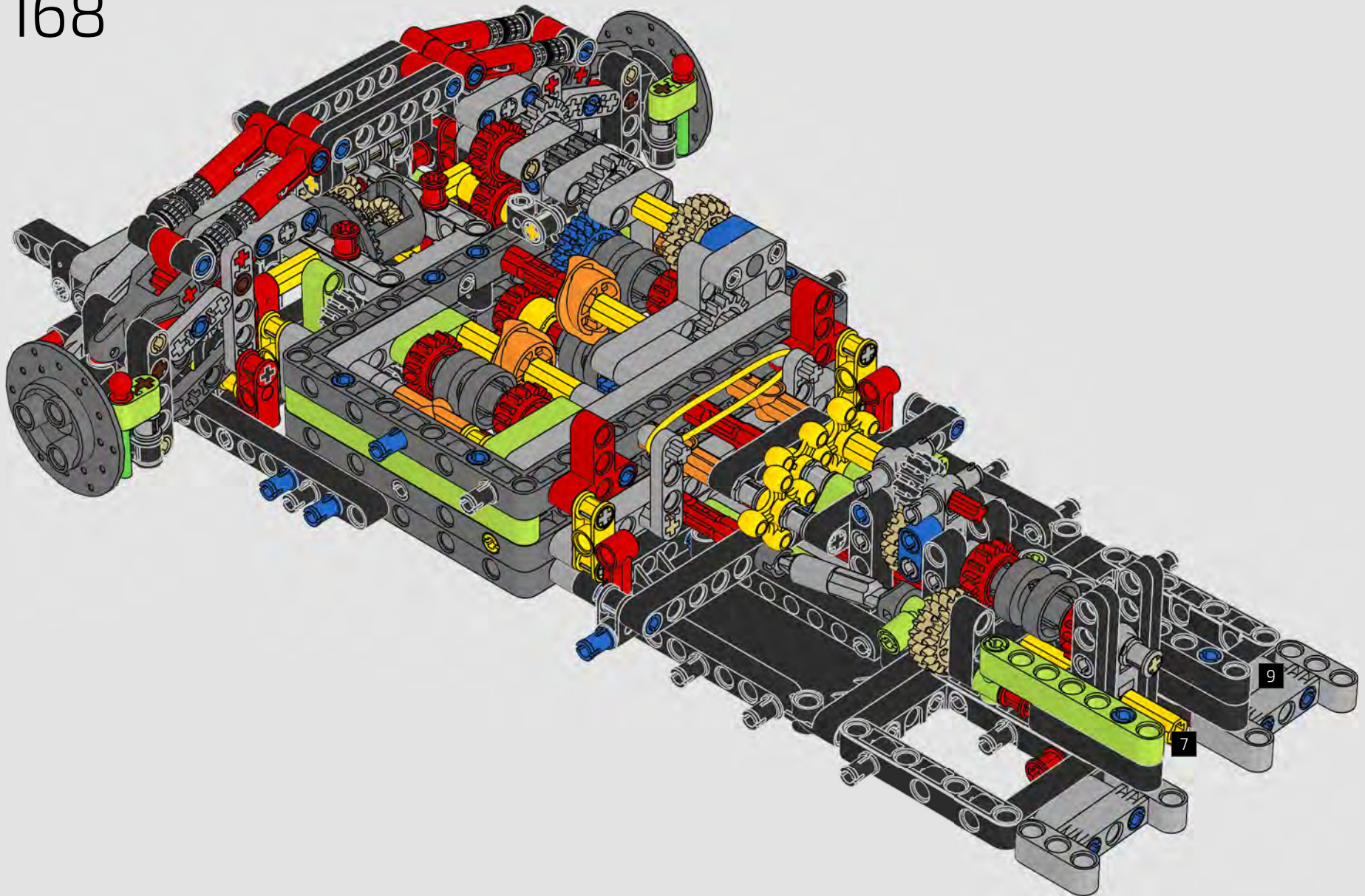

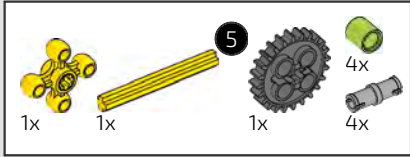

169

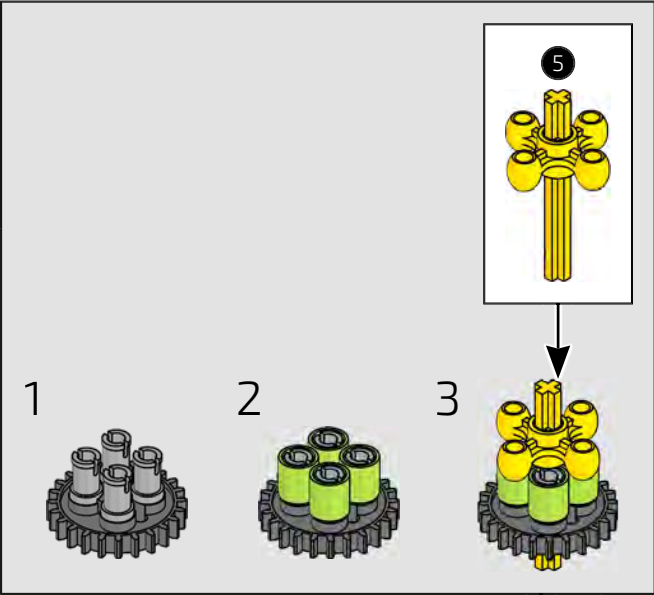
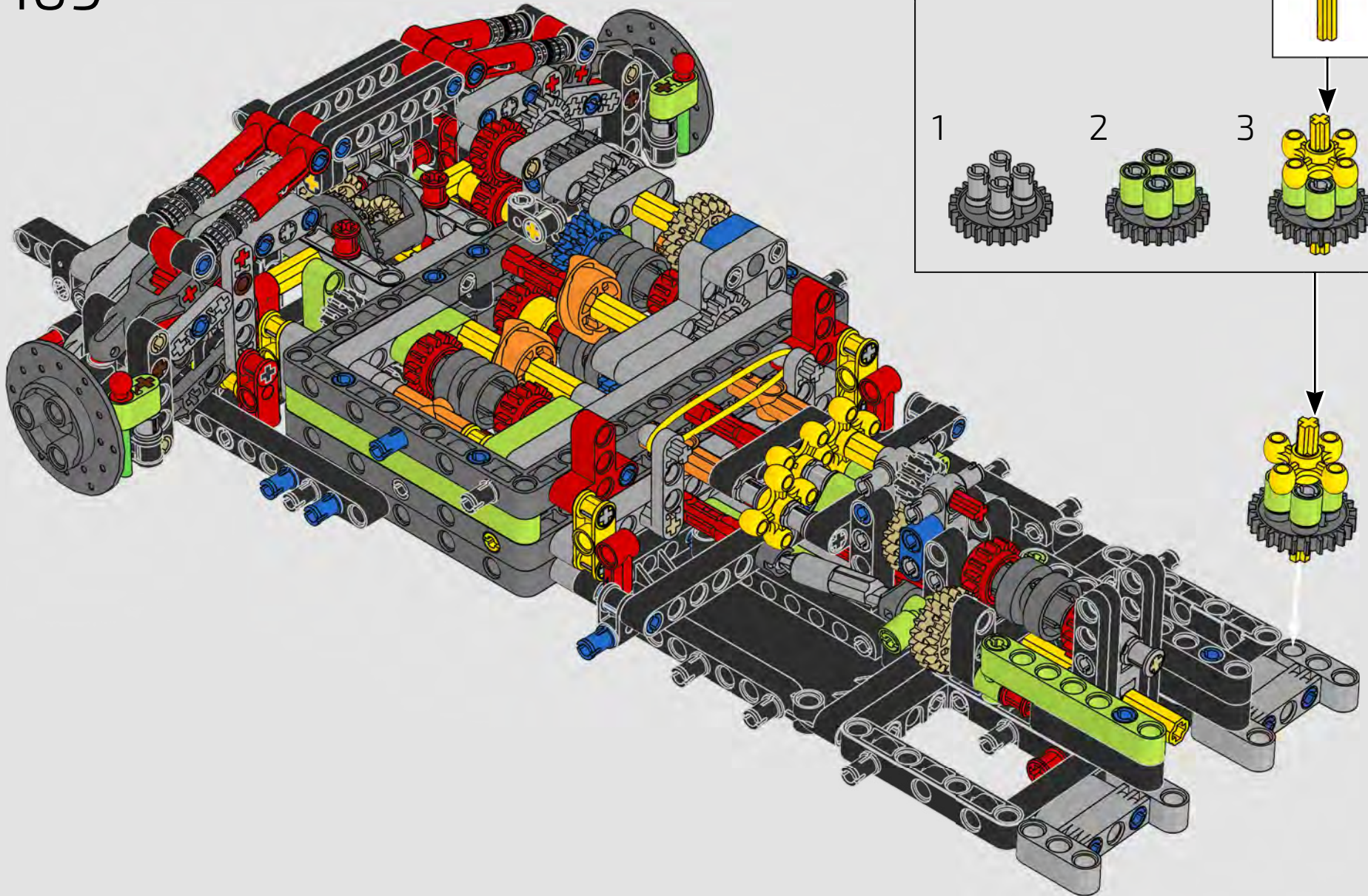

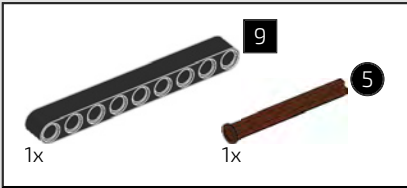
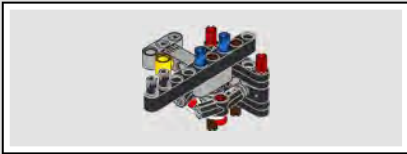

170

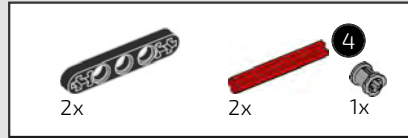
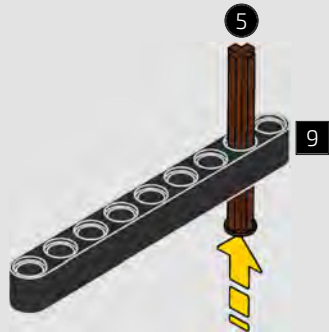

171

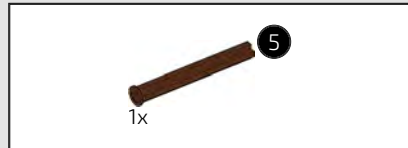
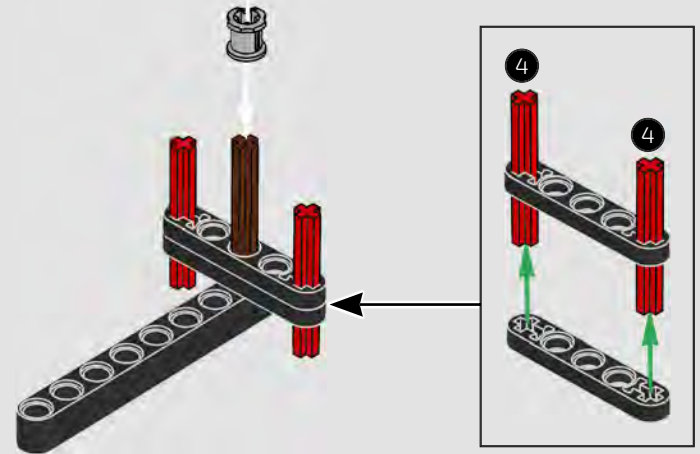
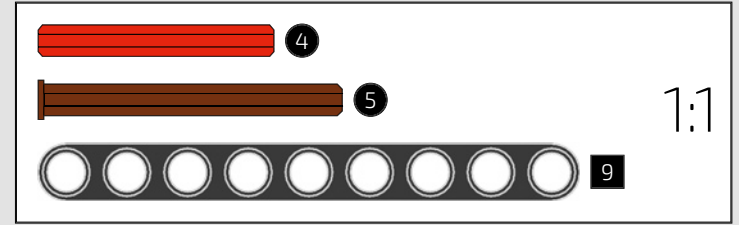

172

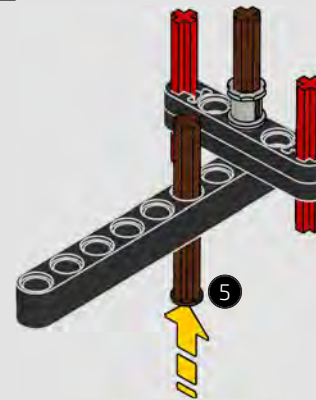

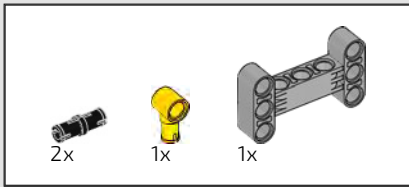

173

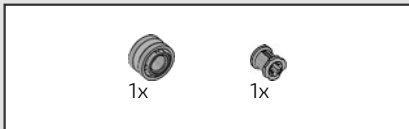
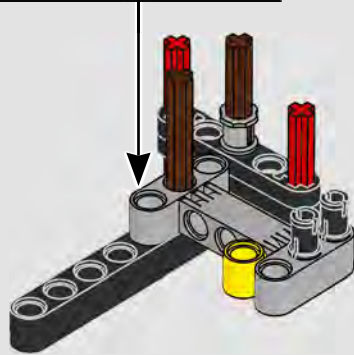
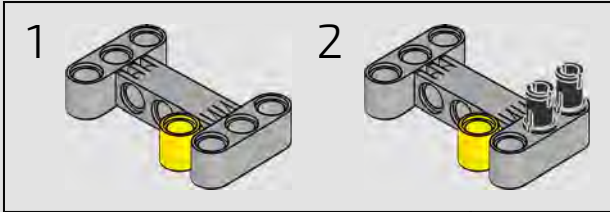

174

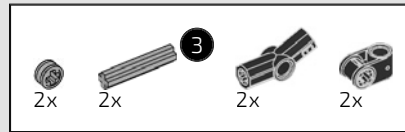
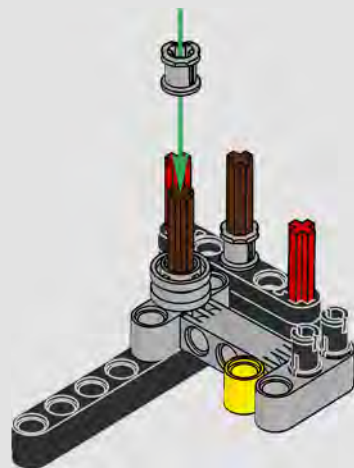

175

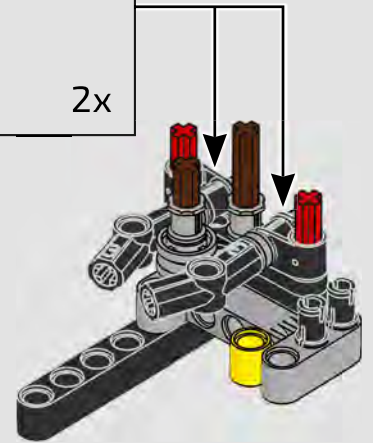
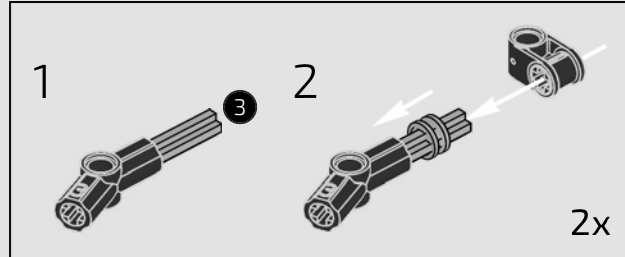

176

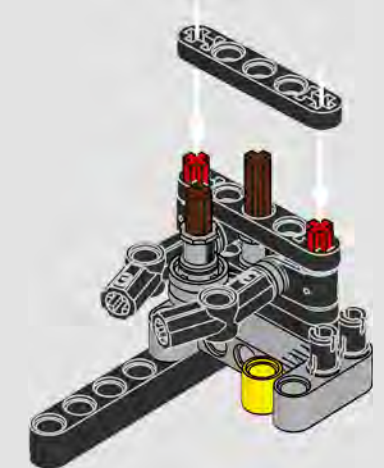



177

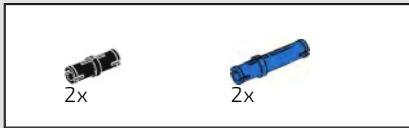
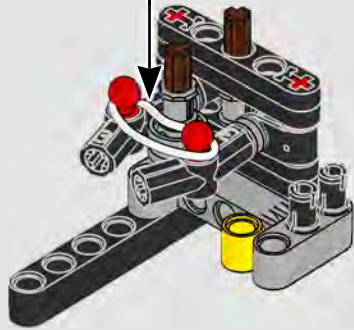
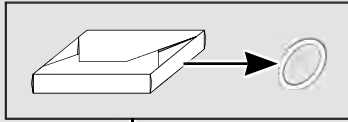

178

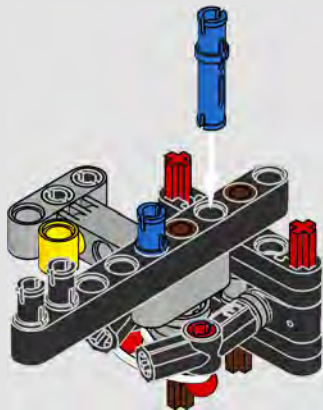

179

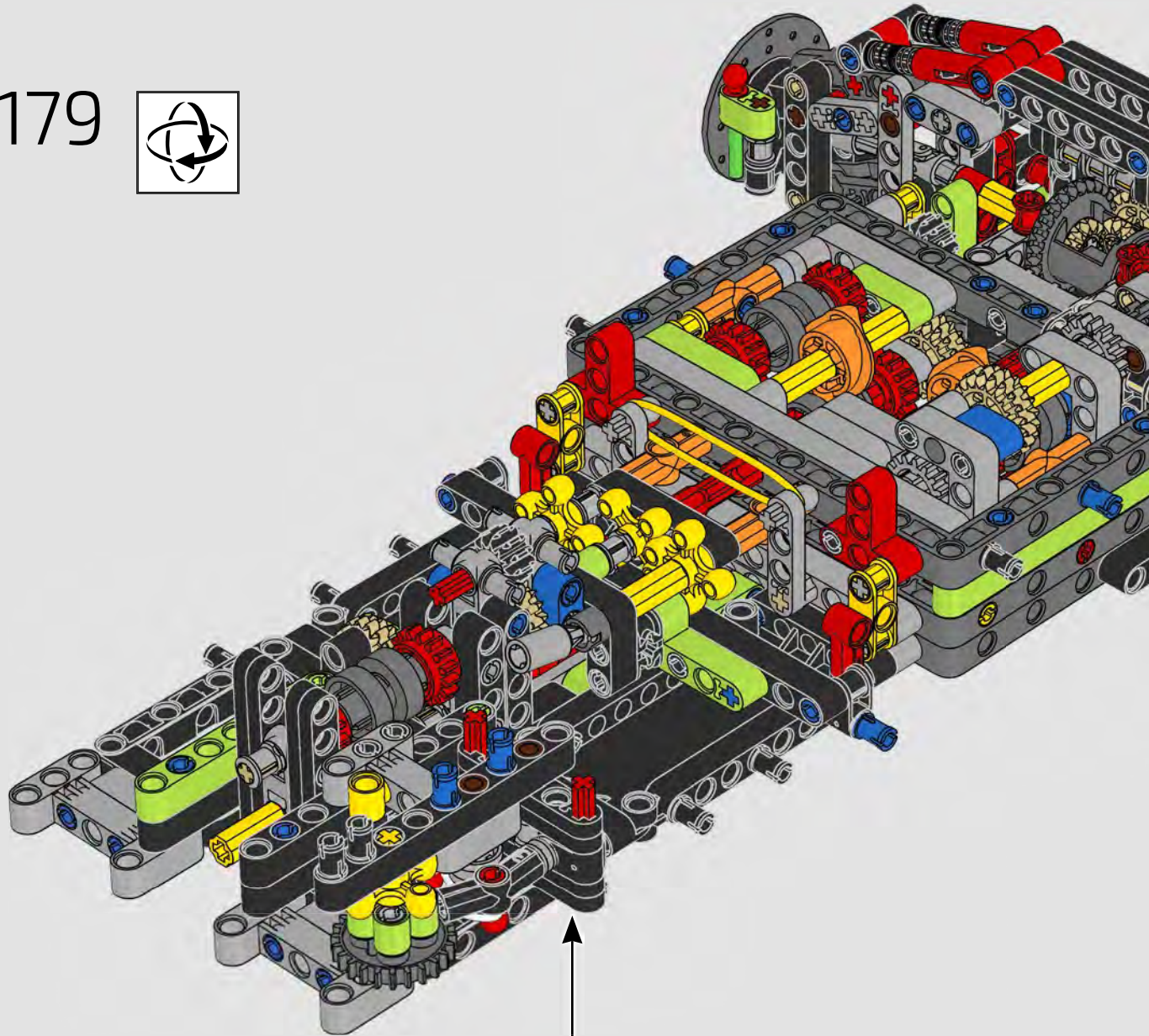

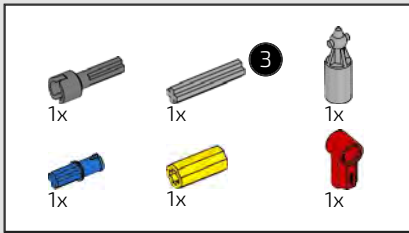

180

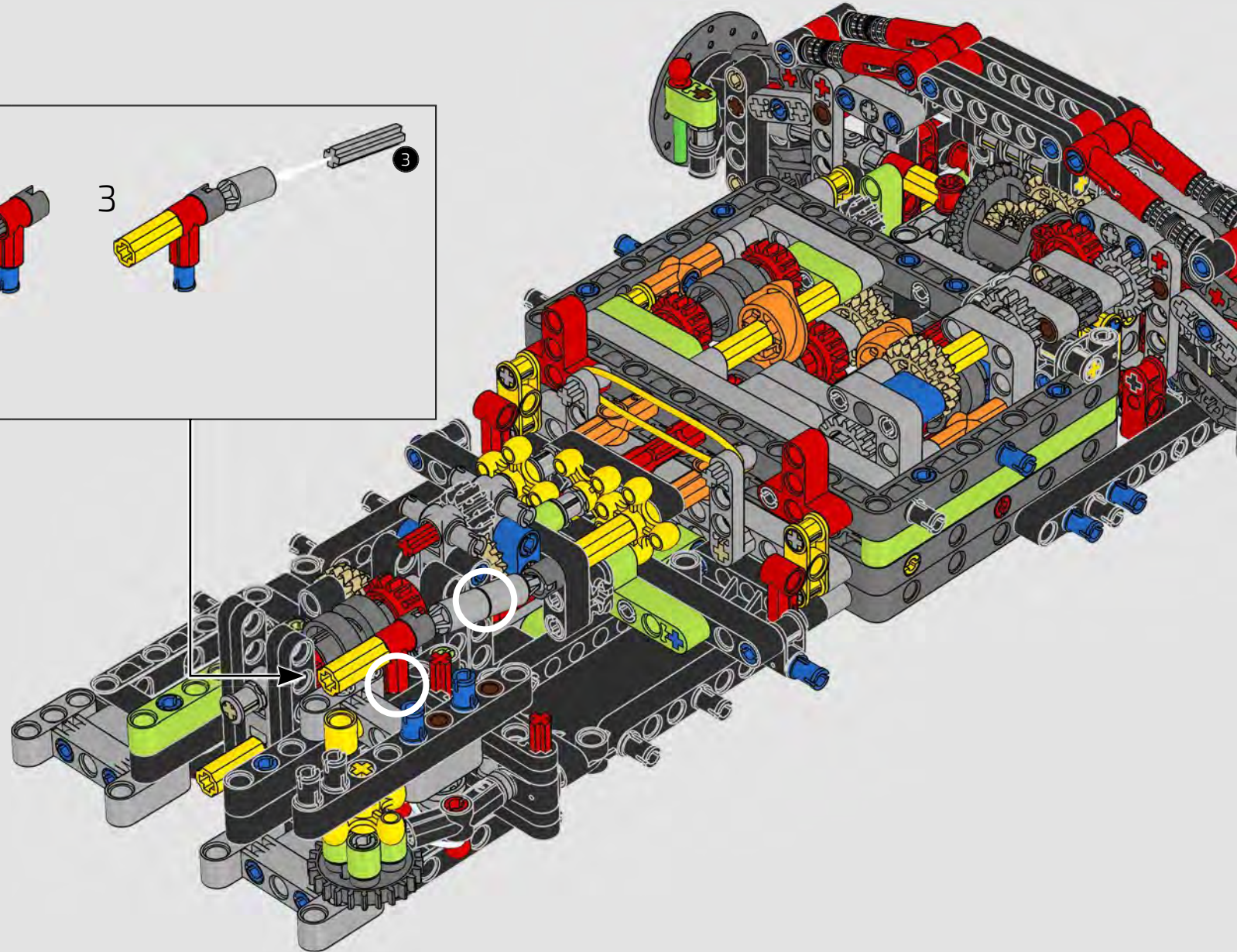
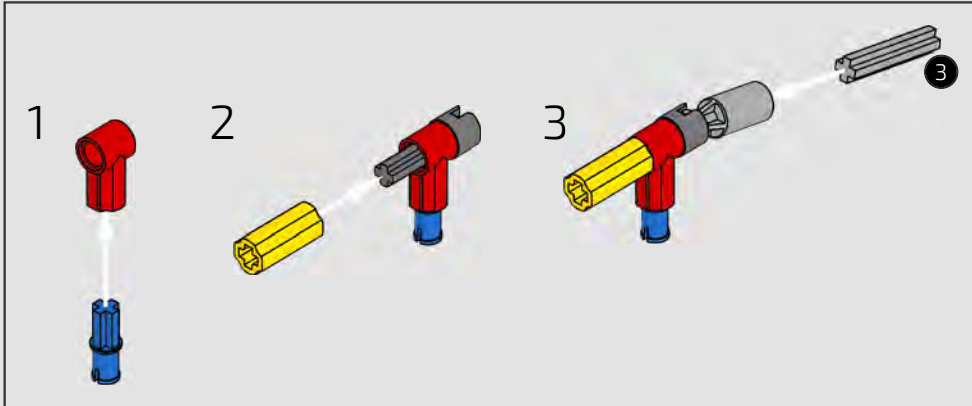

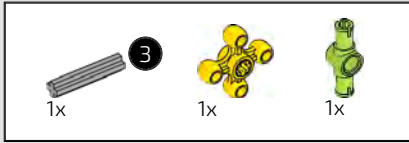

181

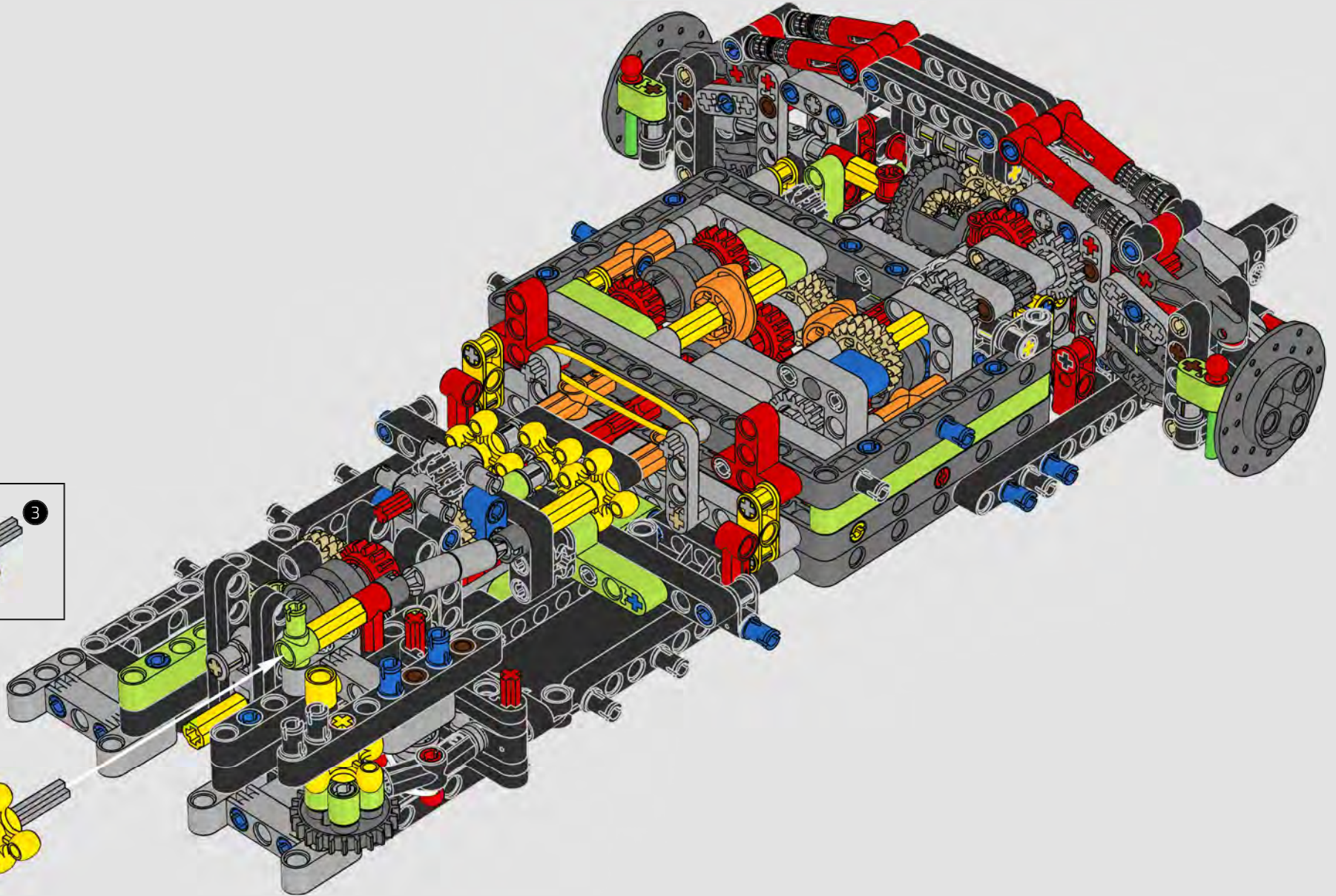
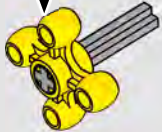
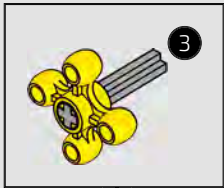





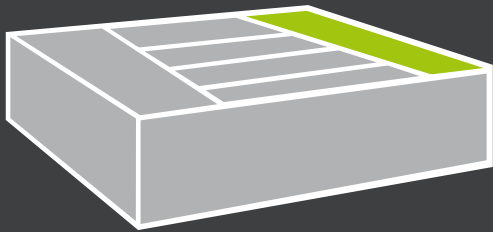

BOX TWO  BOX ZWEI



ENGINE & FRONT SUSPENSION

MOTOR & VORDERRADAUFHÄNGUNG

Both the famous V12 engine and pushrod suspension system are important elements of the Sián FKP 37's DNA, so the LEGO® Technic design team really stretched the Technic building system to recreate them in the final model. Watch Senior Design Manager Jeppe Juul Jensen explain the challenges the designers faced along the way.

Sowohl der berühmte V12-Motor als auch die Pushrod-Aufhängung sind wichtige Bestandteile der DNA des Sián FKP 37. Deshalb ist das LEGO® Technic Designteam an die Grenzen des Technic Bausystems gegangen, um diese Elemente im endgültigen Modell nachzubilden. Schauen Sie sich an, wie Senior Design Manager Jeppe Juul Jensen die Herausforderungen beschreibt, mit denen sich die Designer während des Projekts konfrontiert sahen.



> www.LEGO.com/lamborghini-sian/videocasts



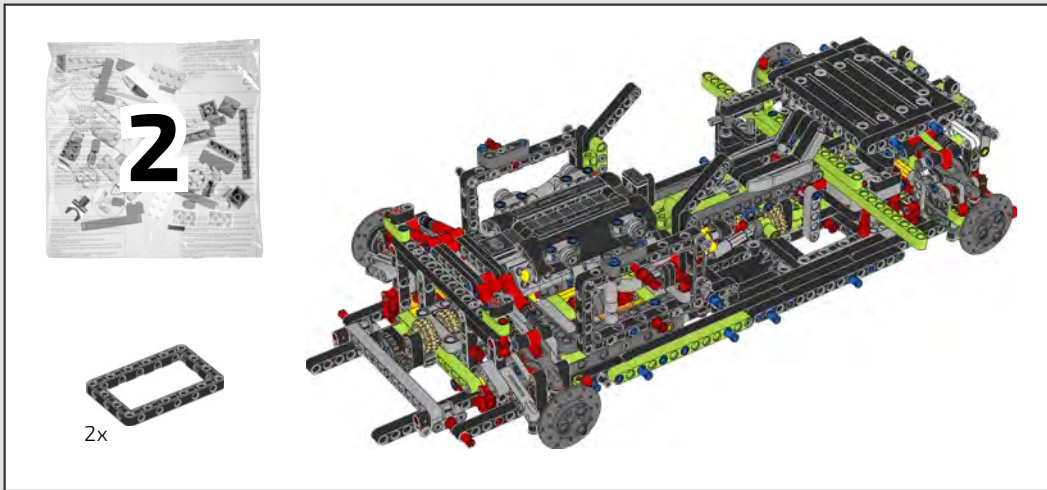

182

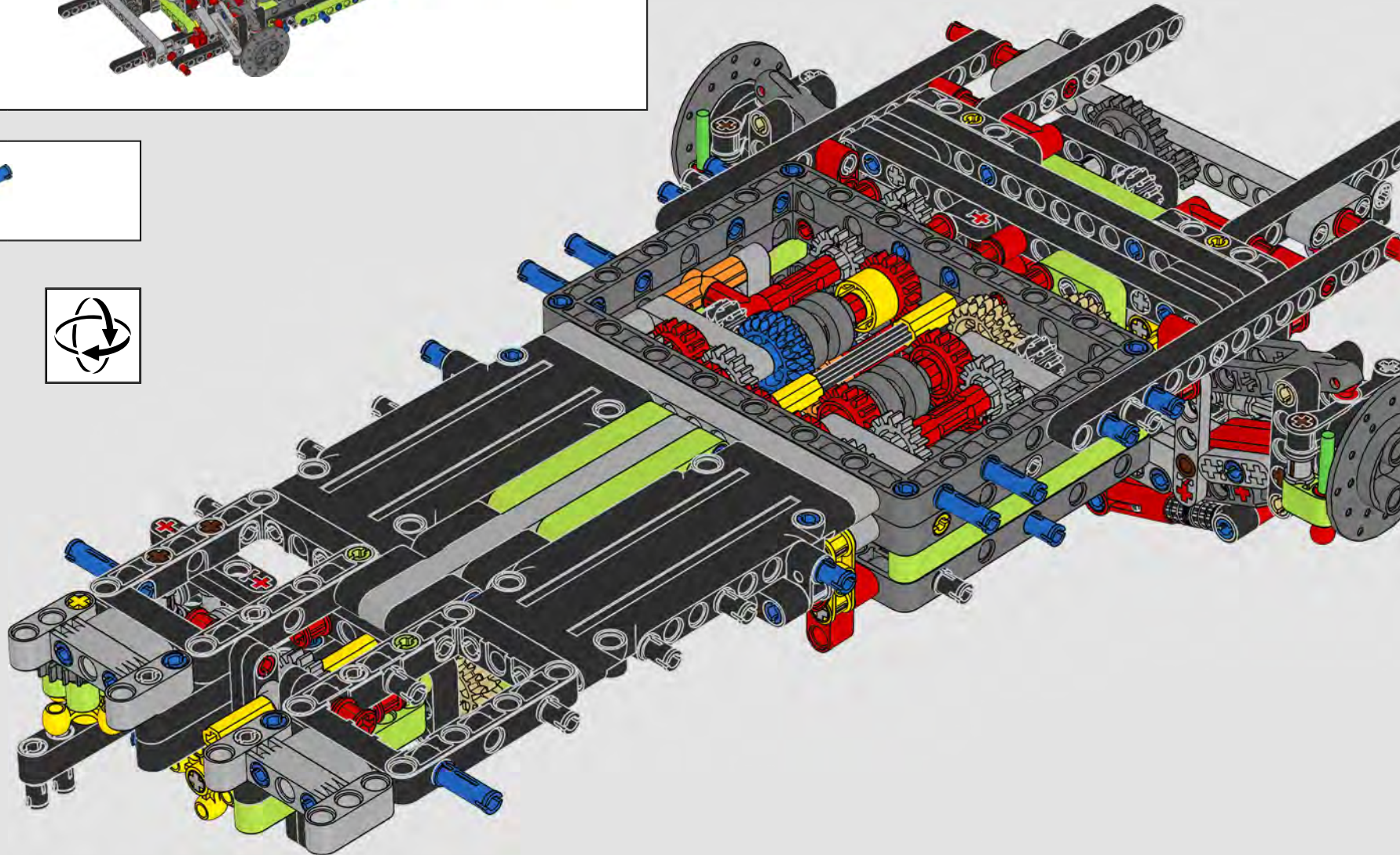



2x

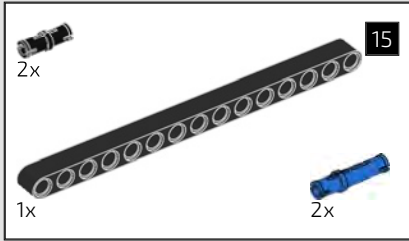

183

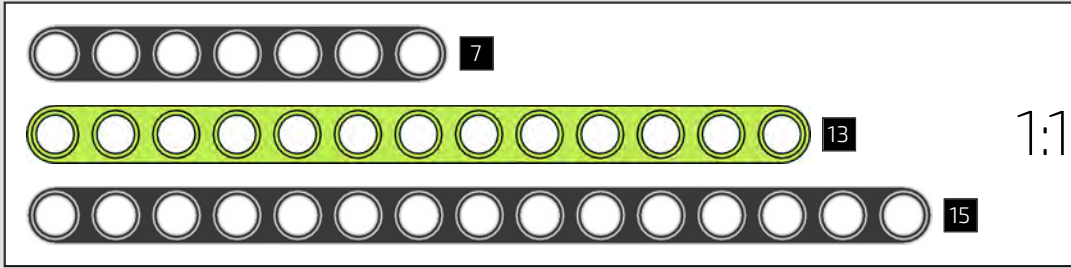

1:1



15

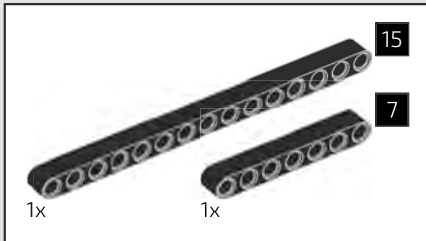

184



185

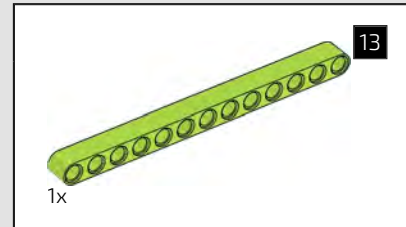
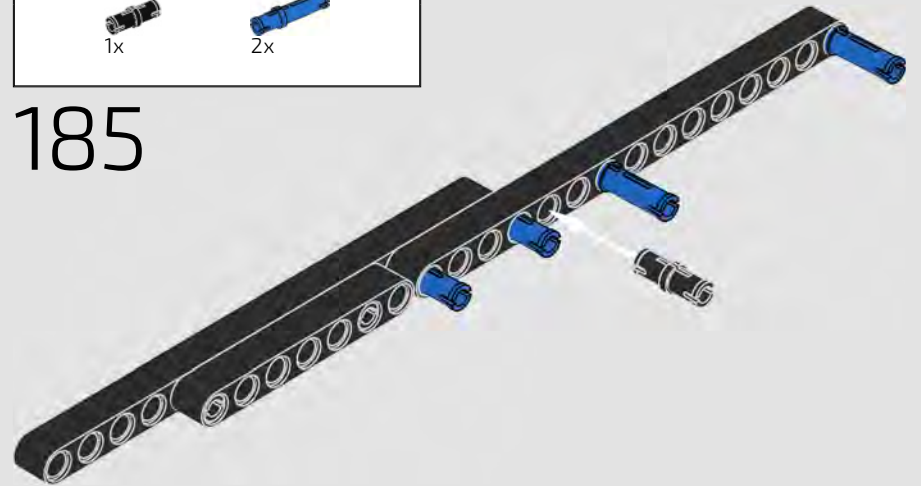

186

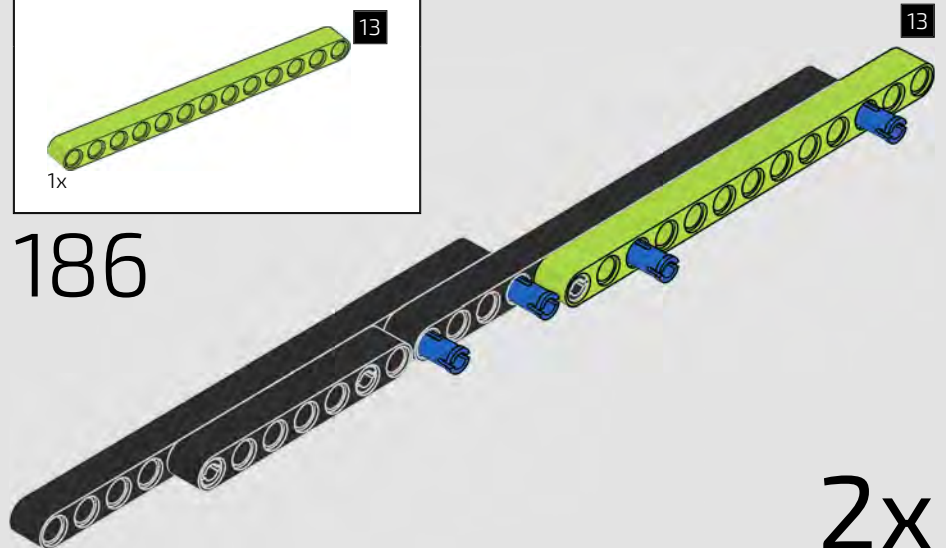

2x

187

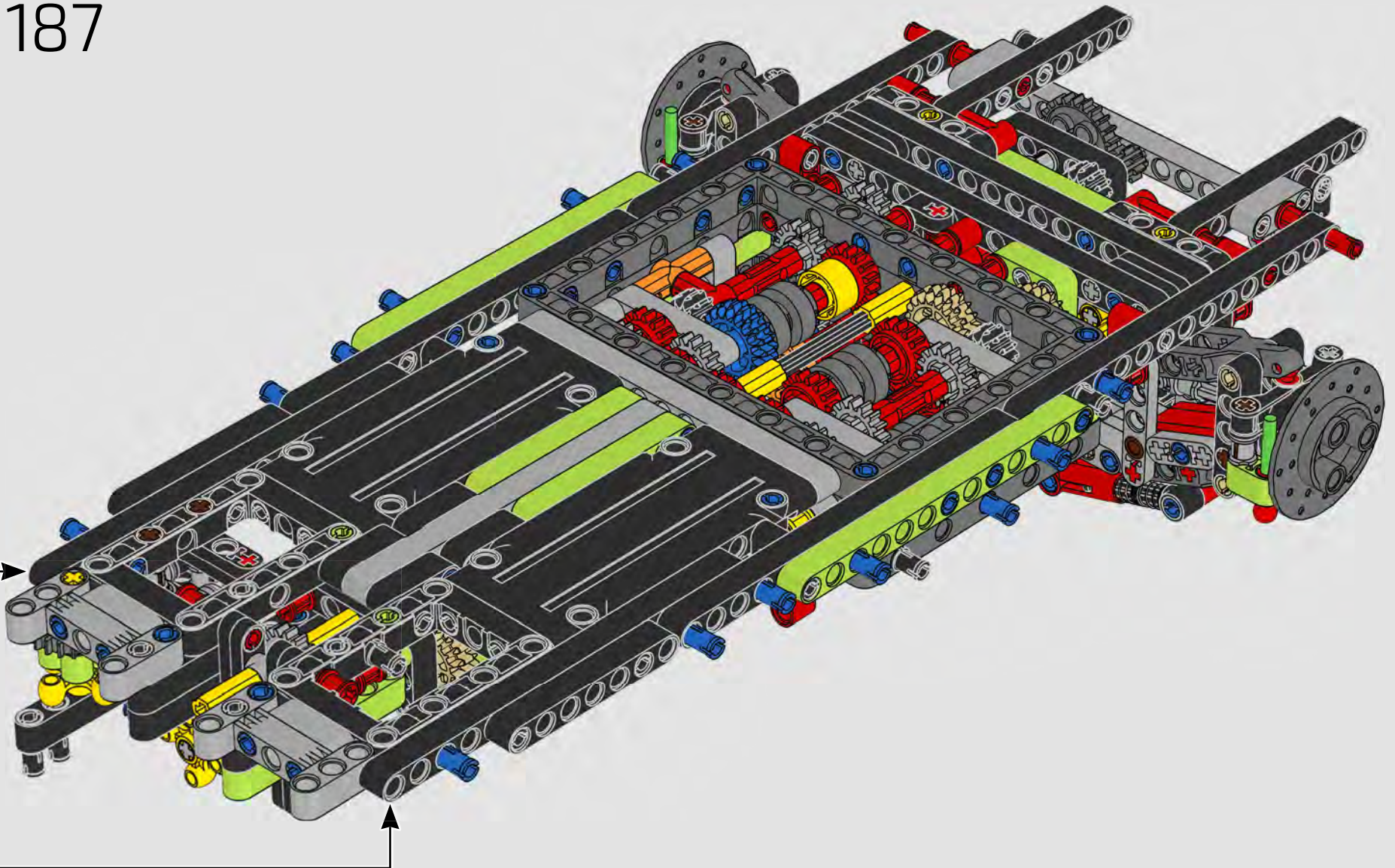

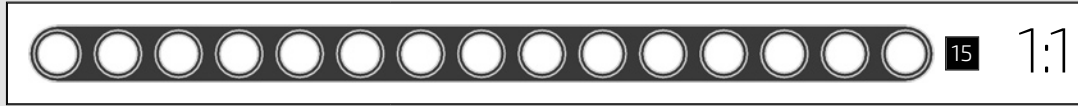
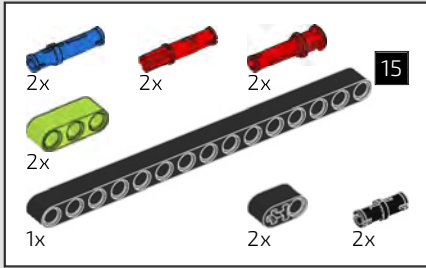

188

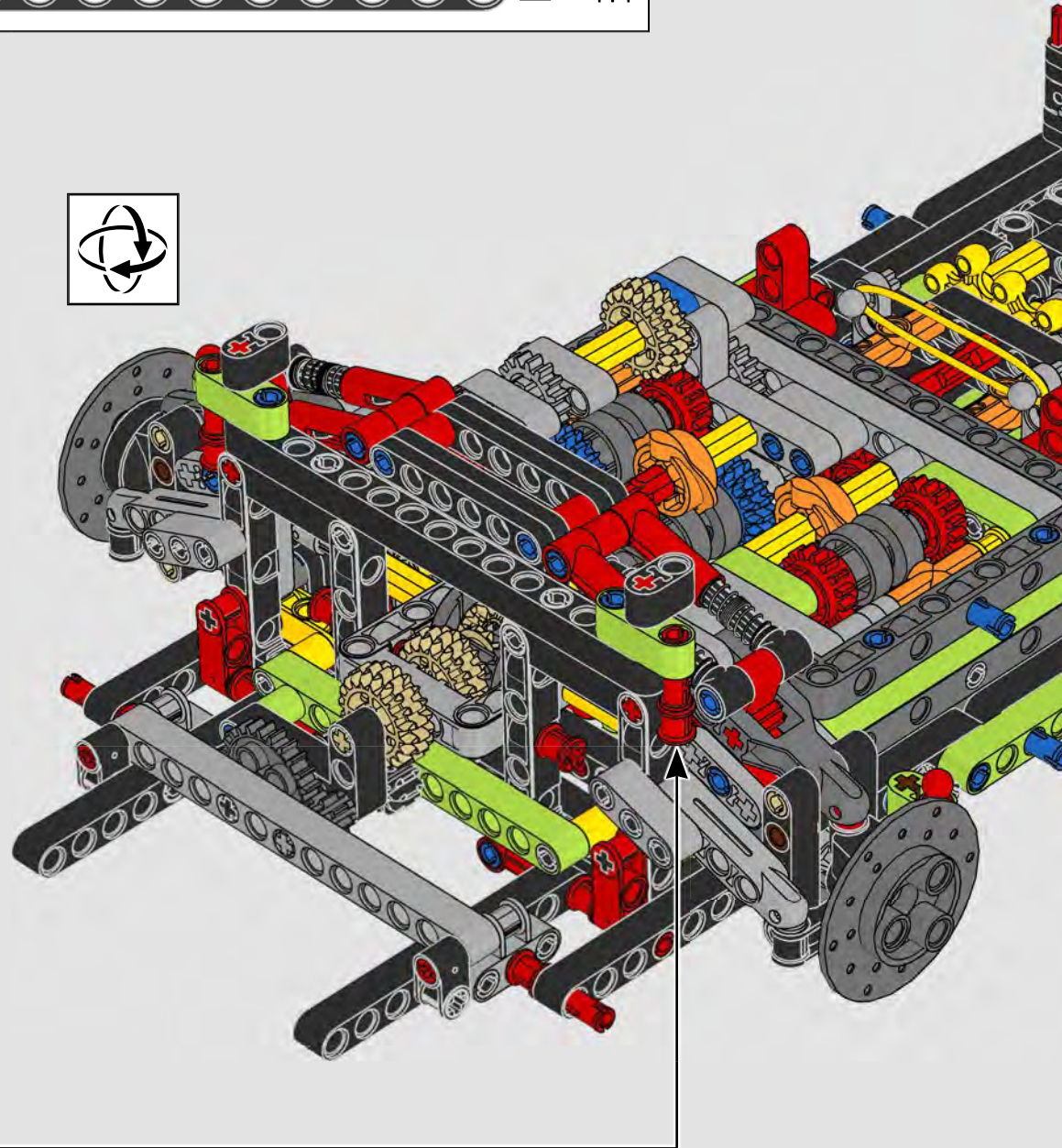
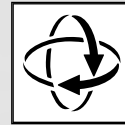
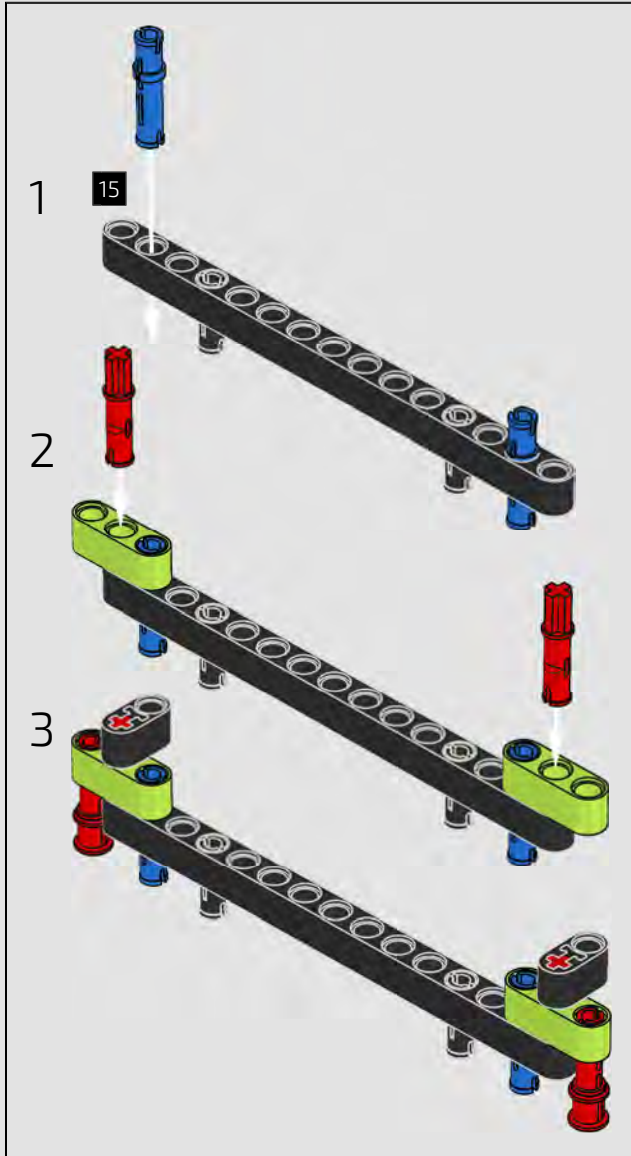

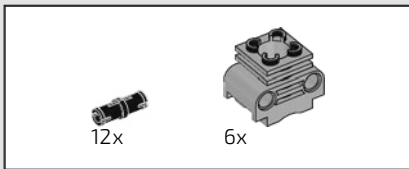
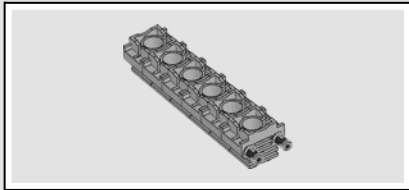
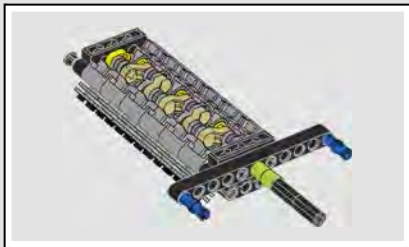

189

1

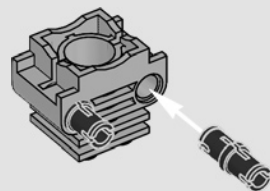

2

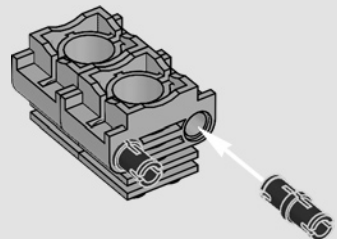

3

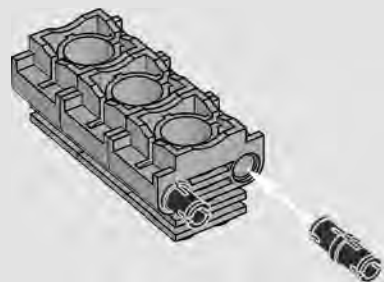

4

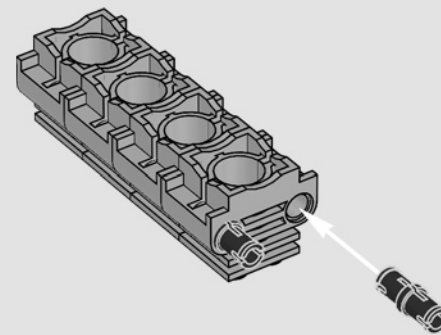

5

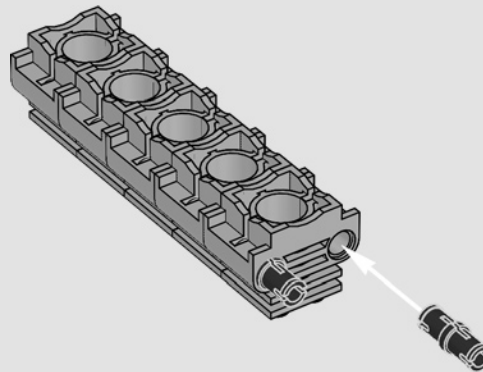

6

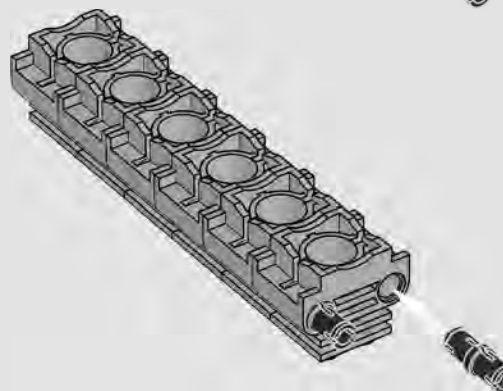

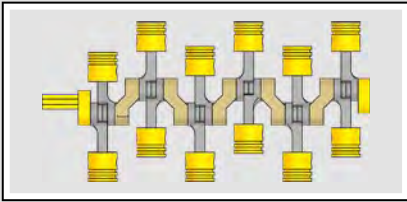

190

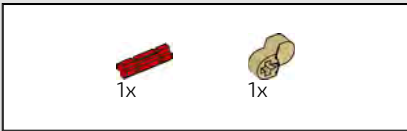
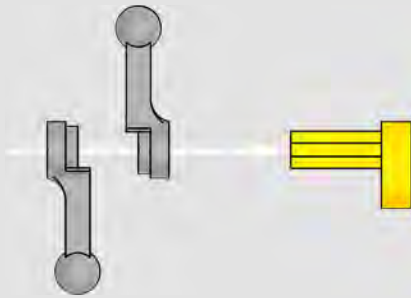

191

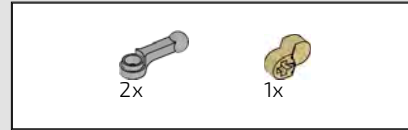
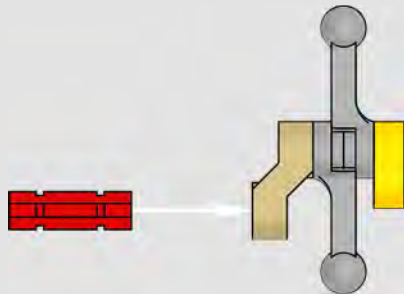

192

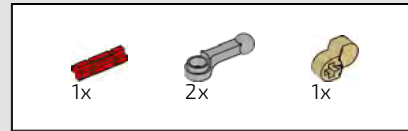
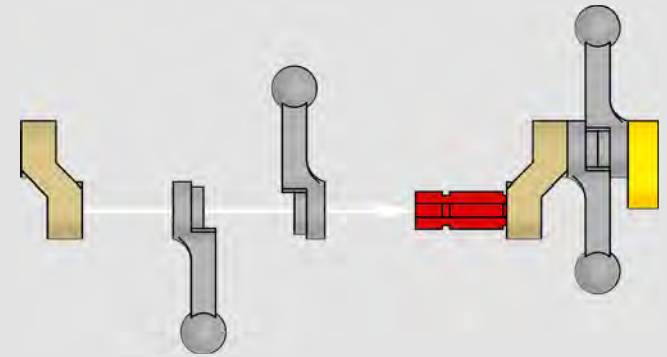

193

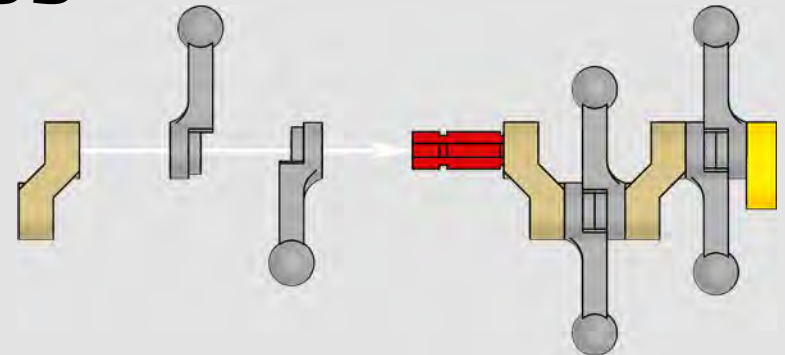

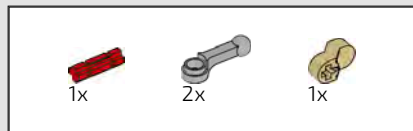

194

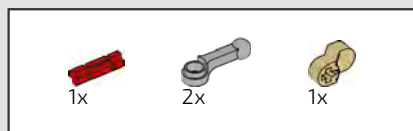
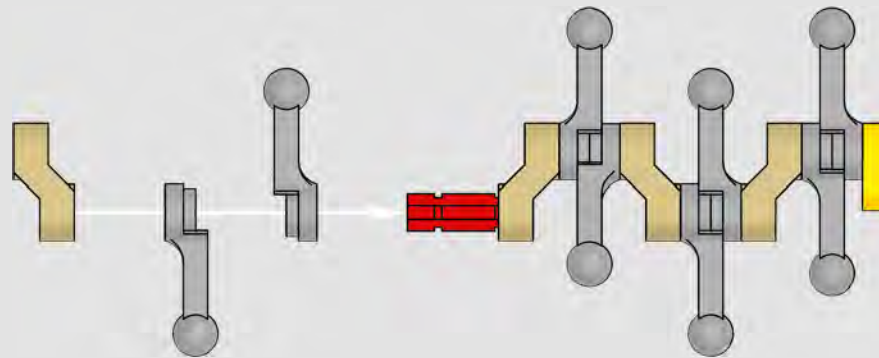

195

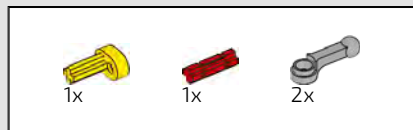
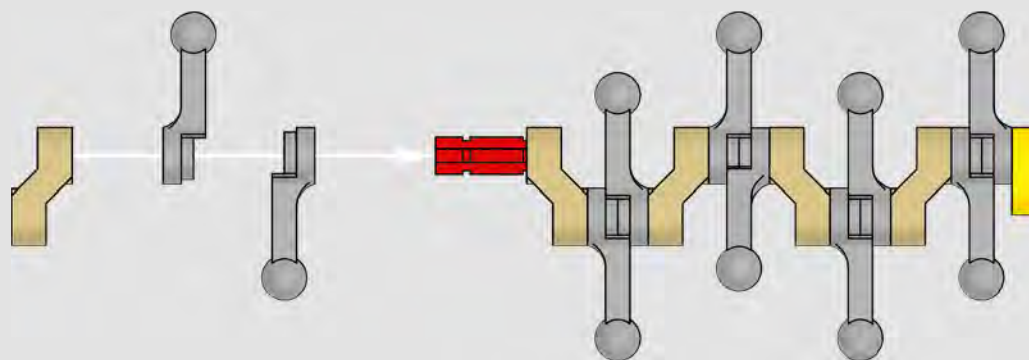

196

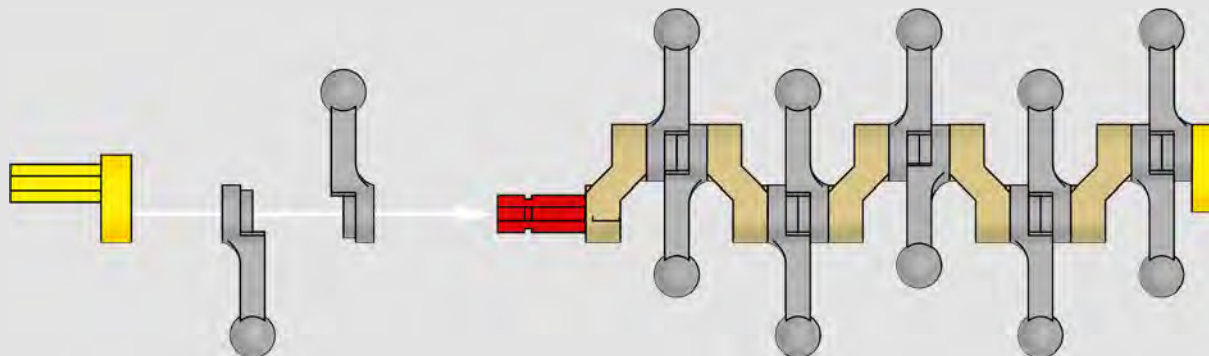



197

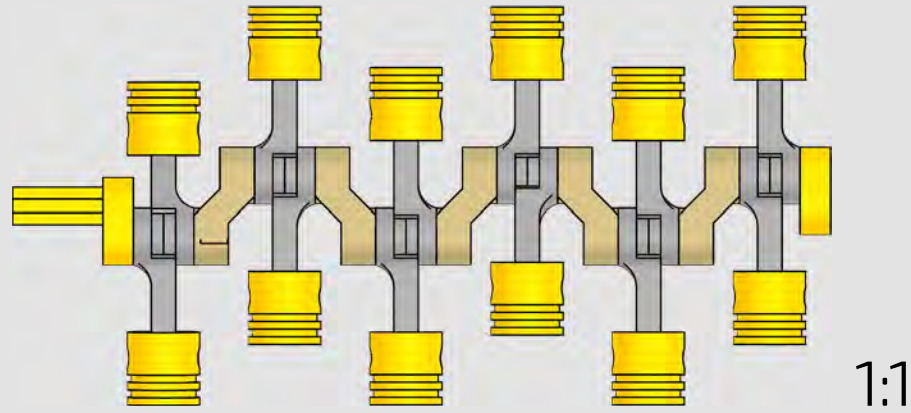

198

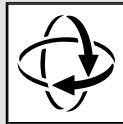
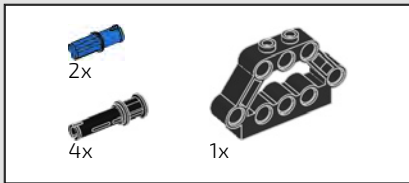
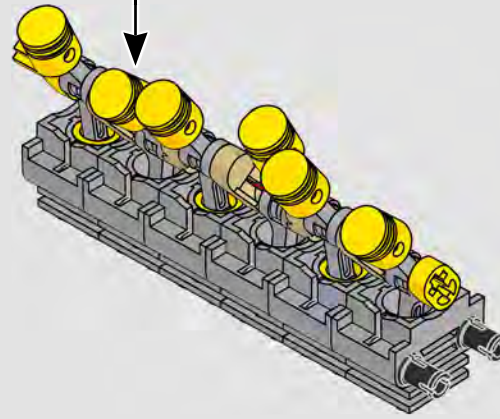

199

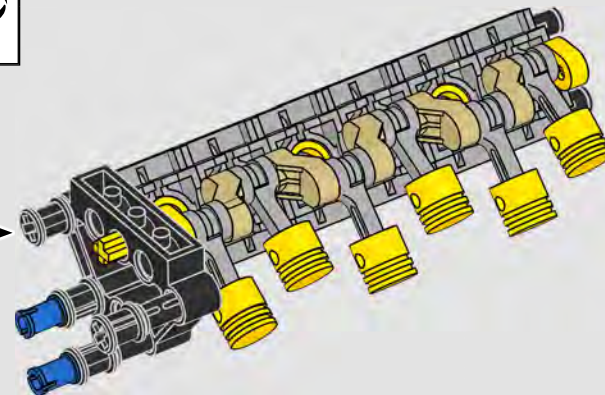
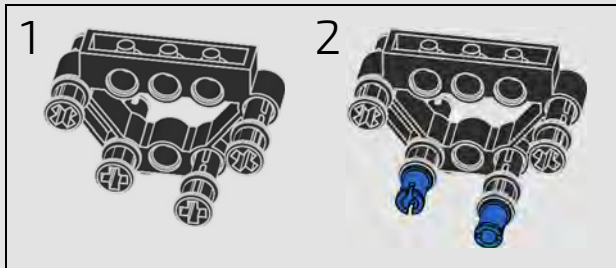

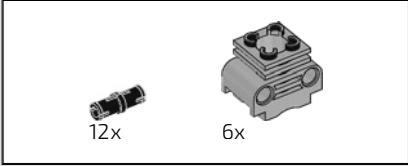
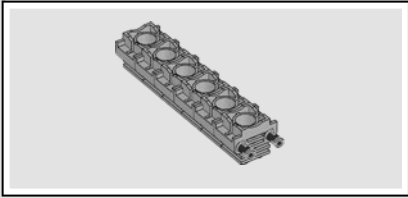

200

1

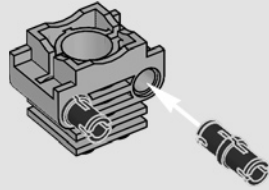

2

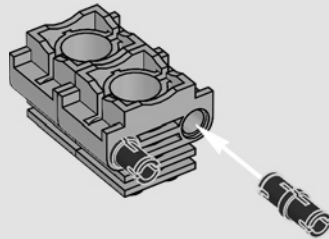

3

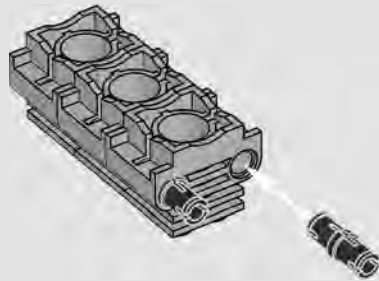

4

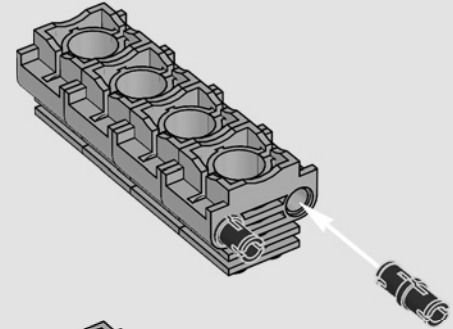

5

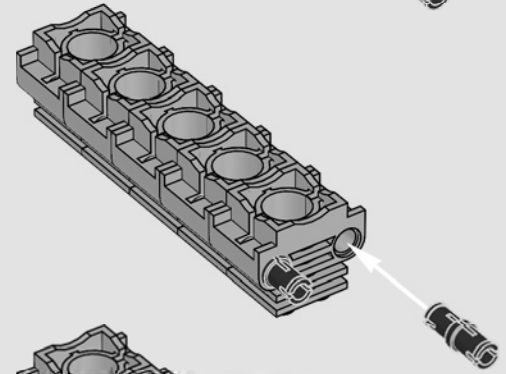

6

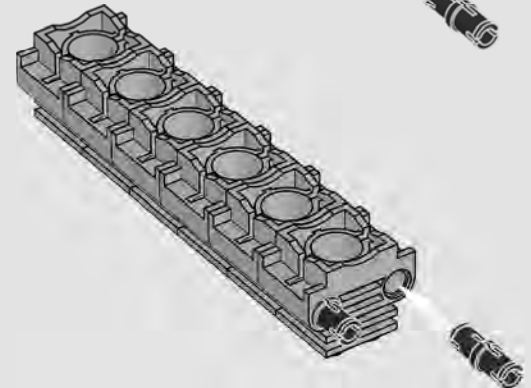

201

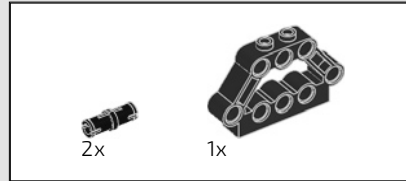
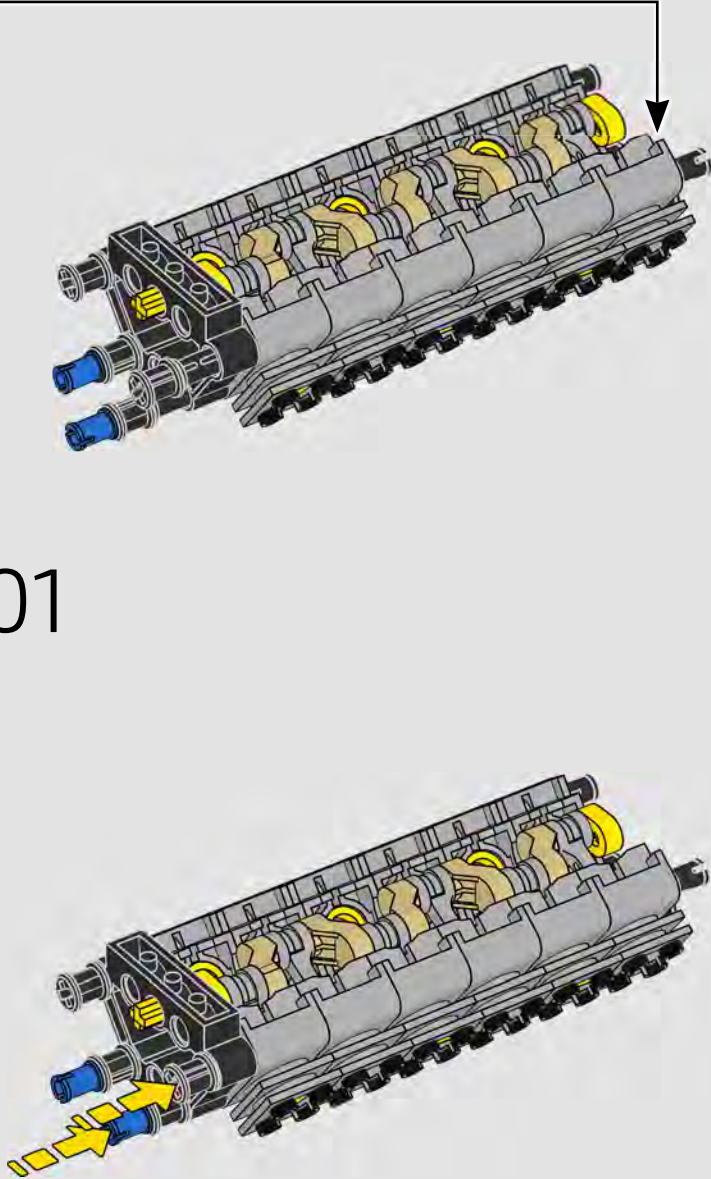

202

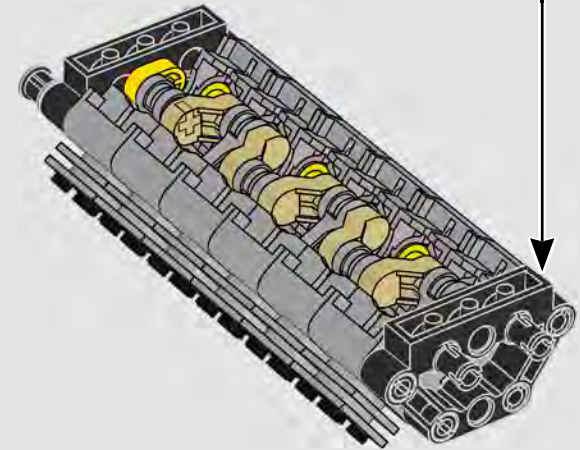
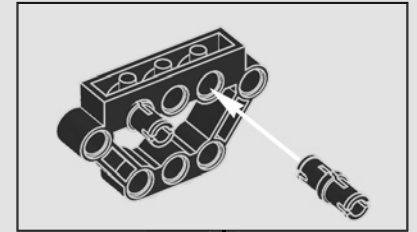

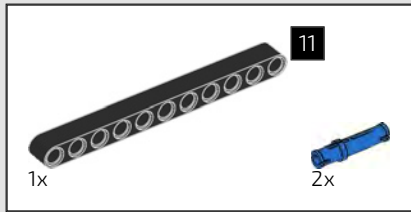

203

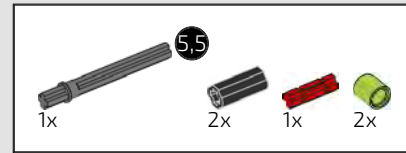
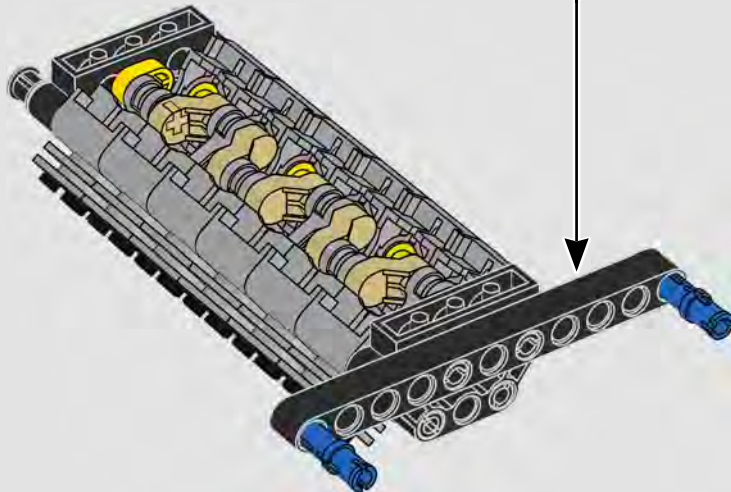
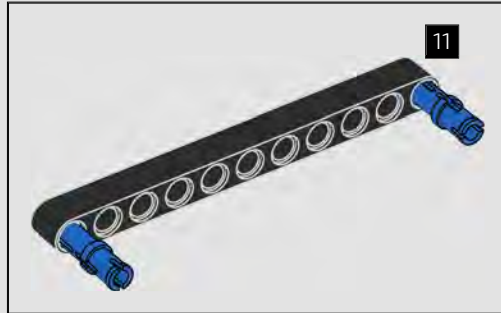

204

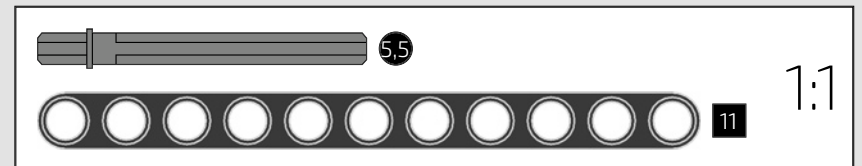
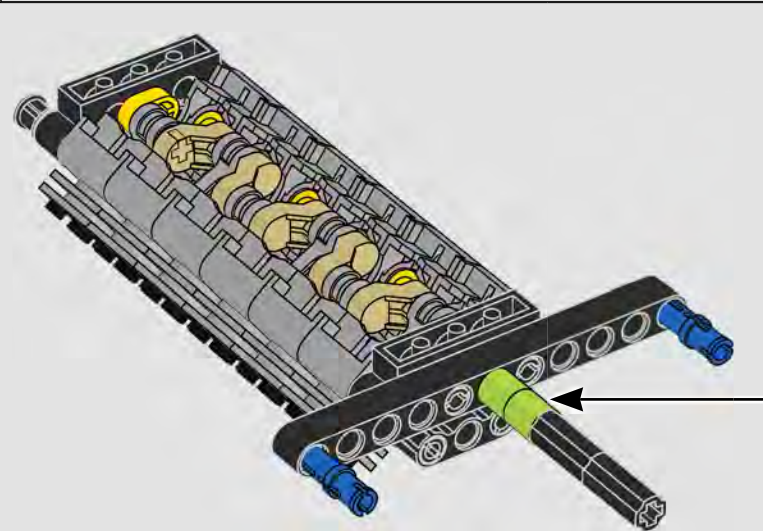
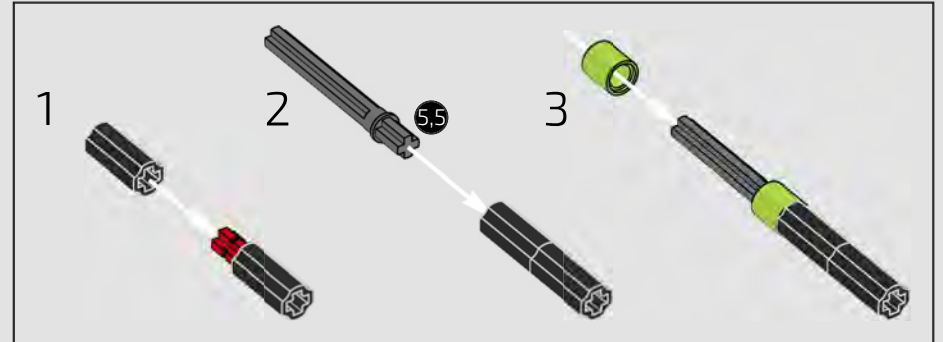

205

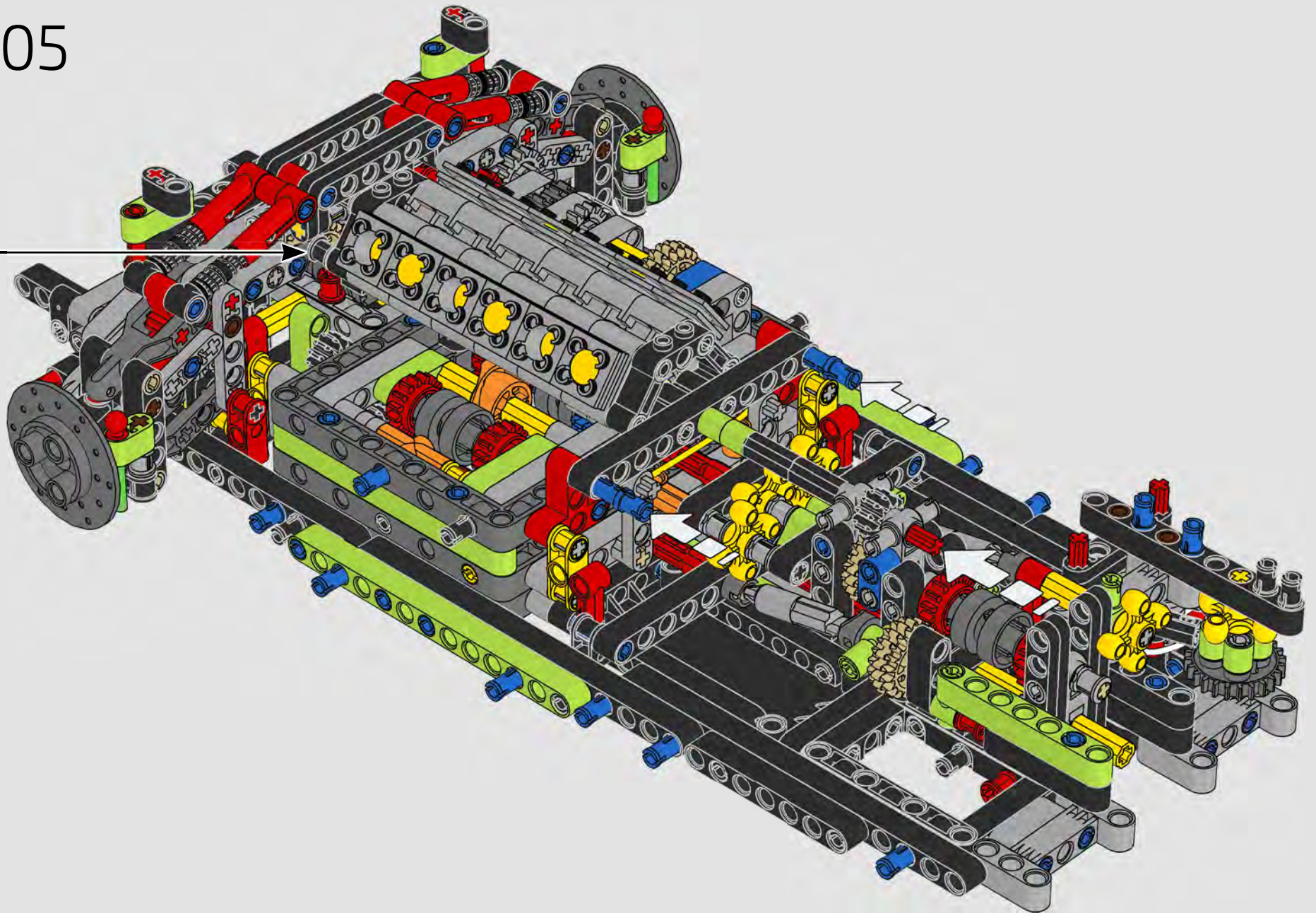

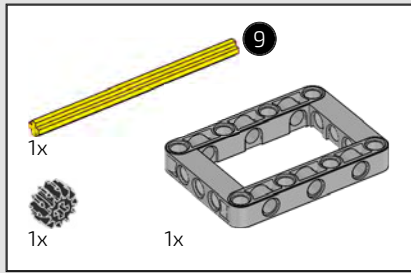

206

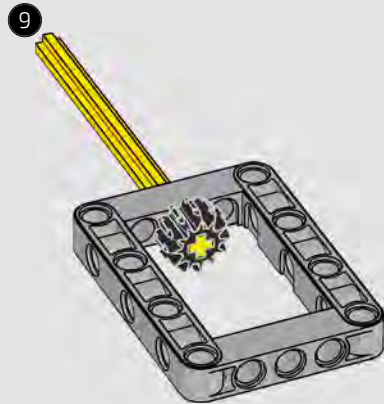

207

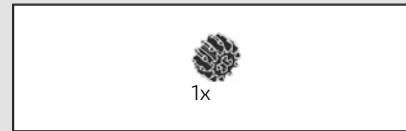
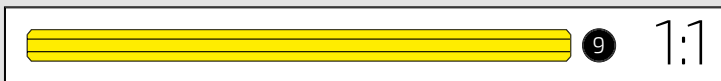
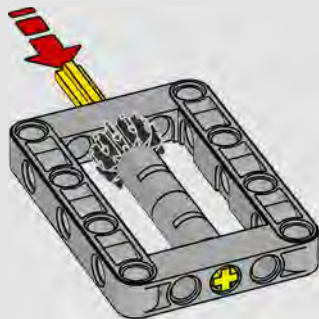

208

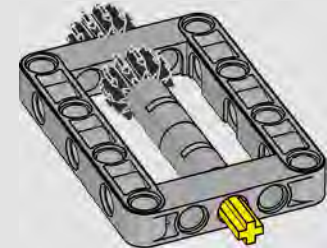

209

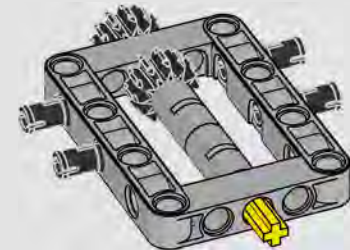



210

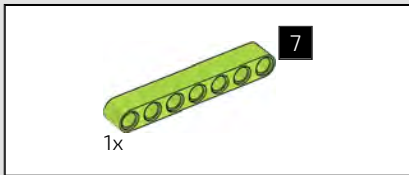
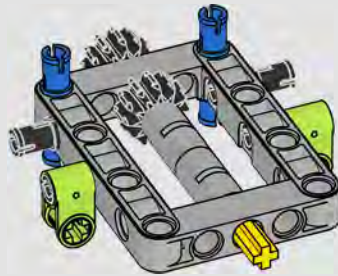

211

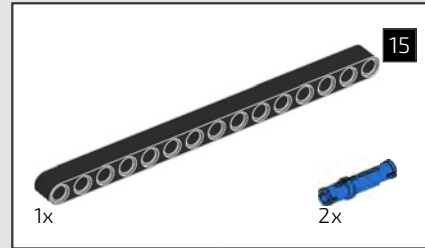
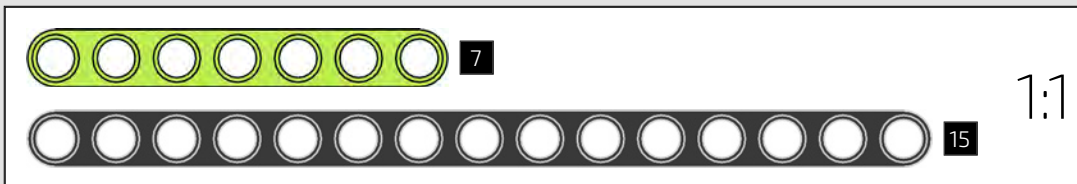
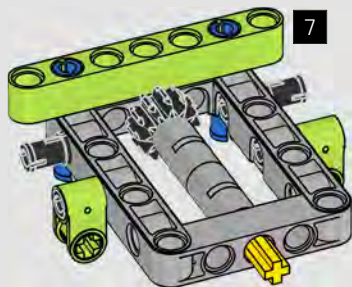

212

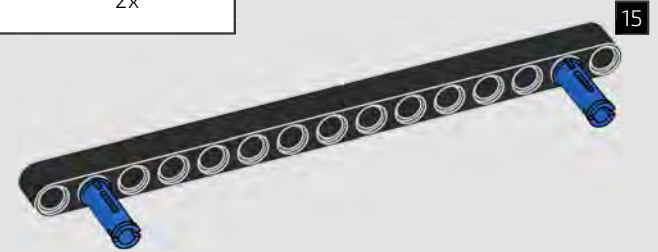

213



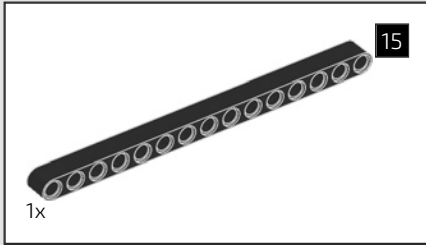

214

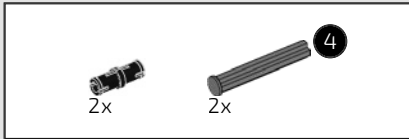
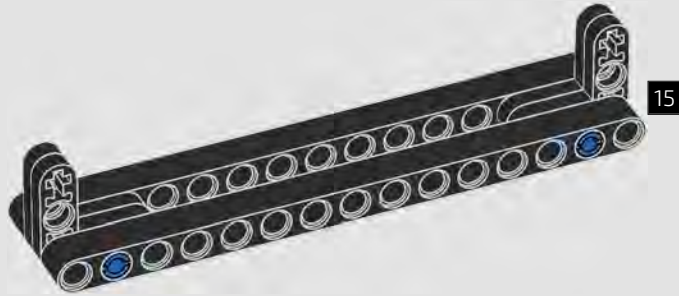

215

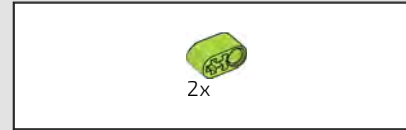
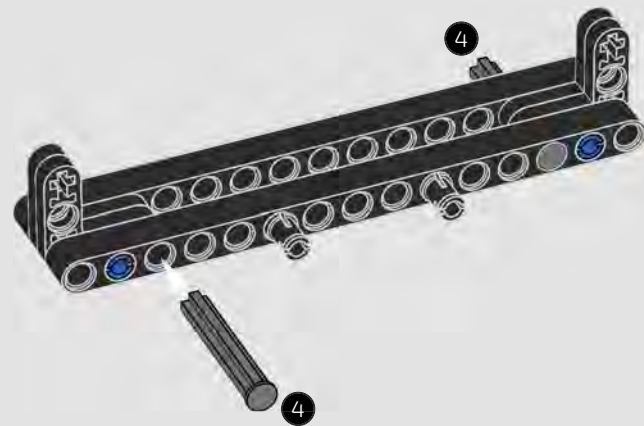

216

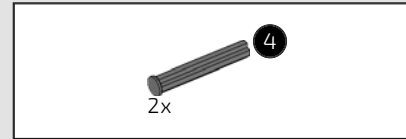

217

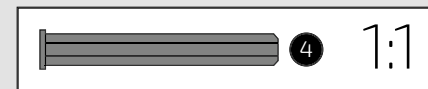
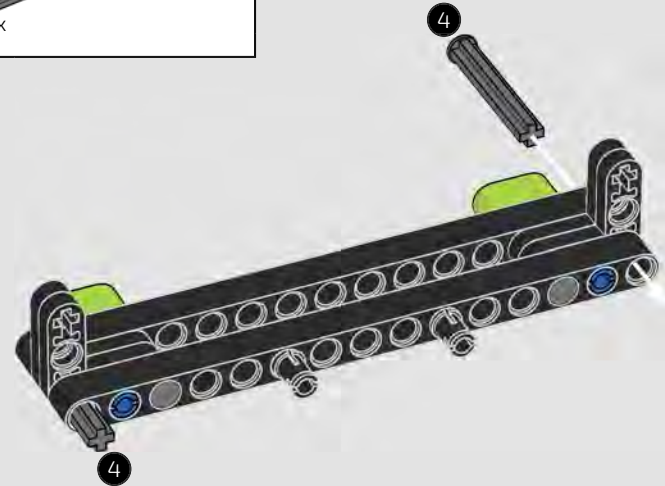

218

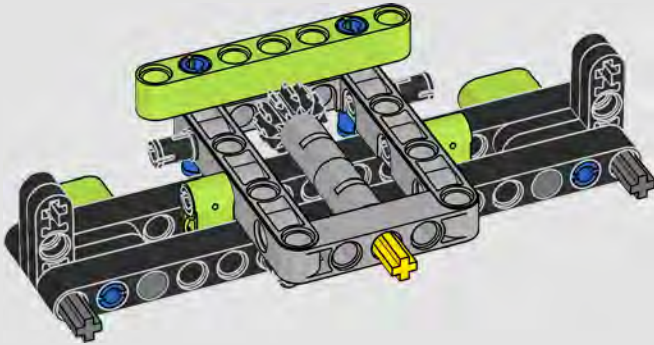

219

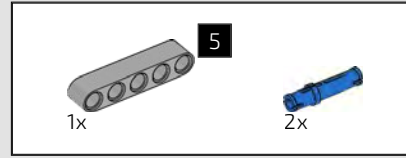
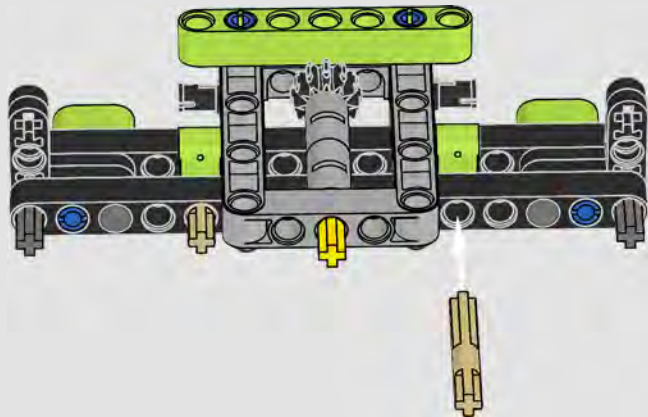

220

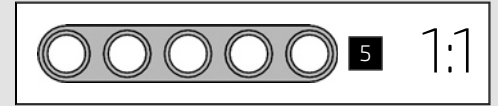
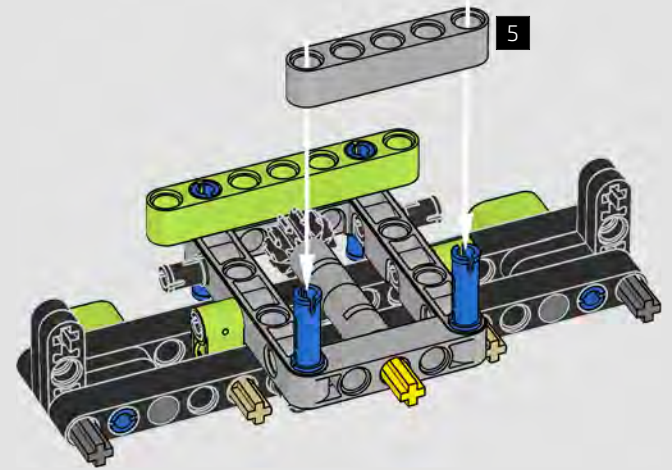

221

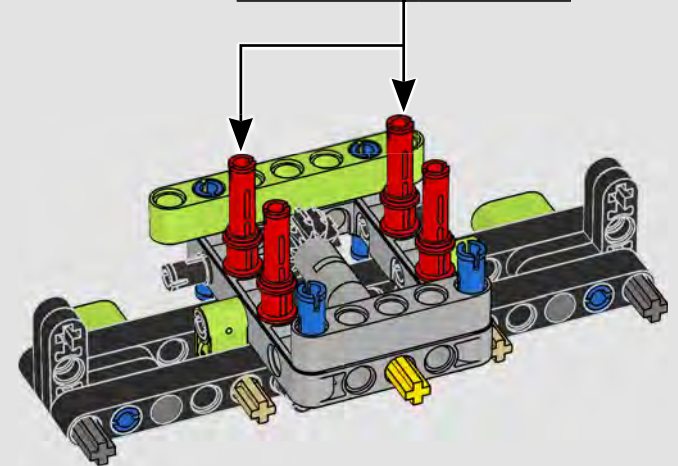
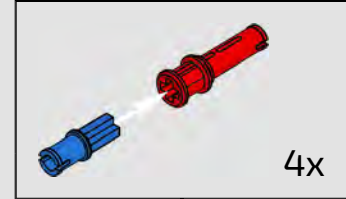

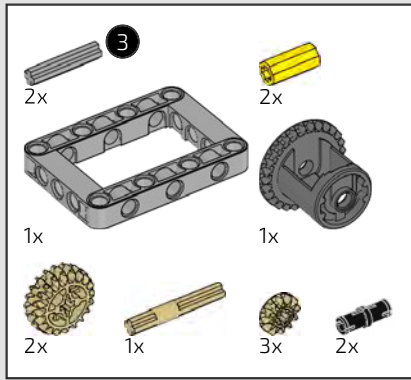

222

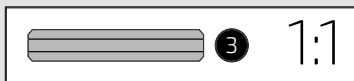
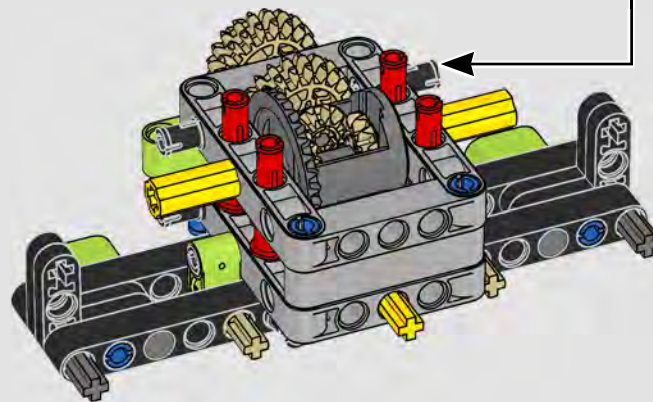
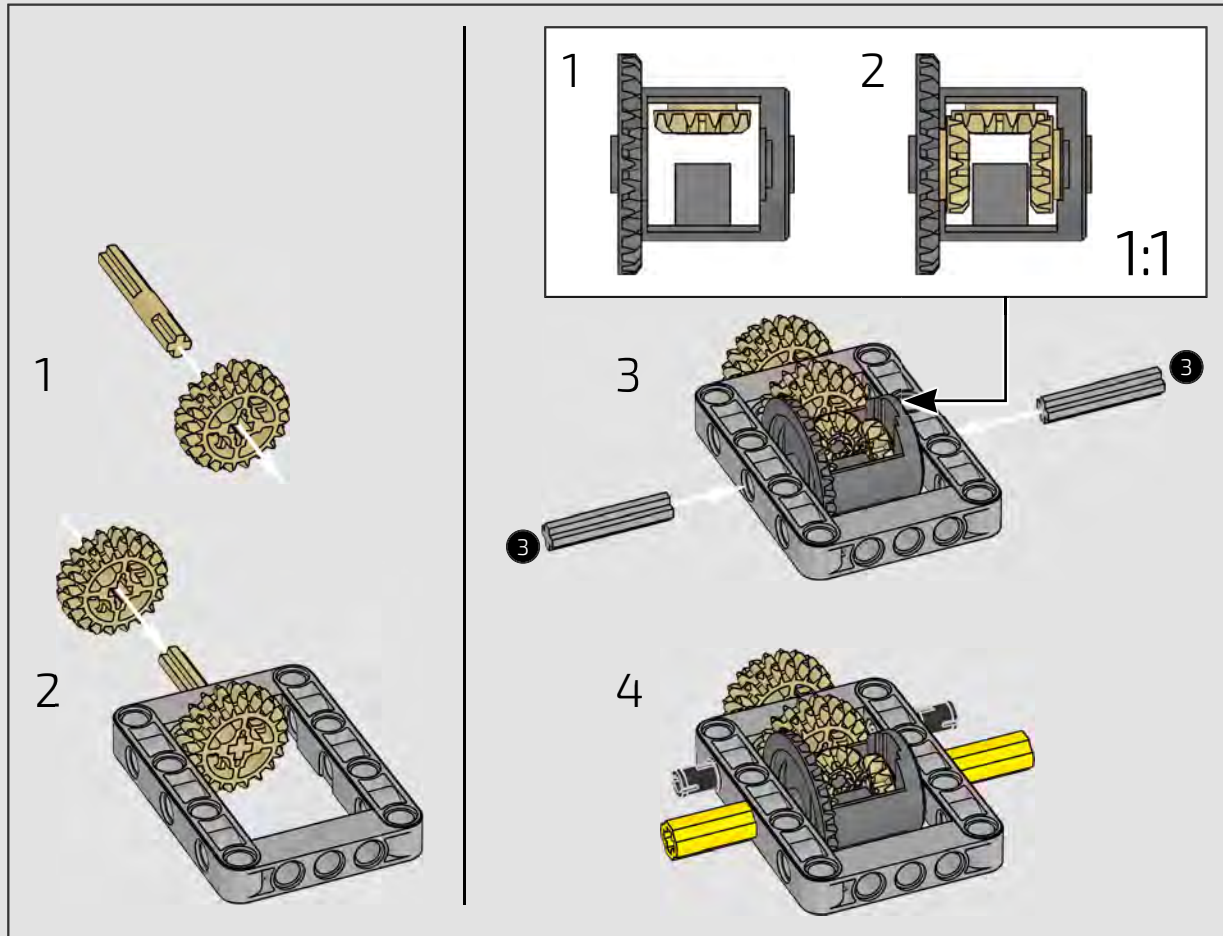



223

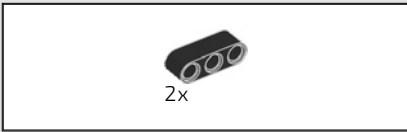
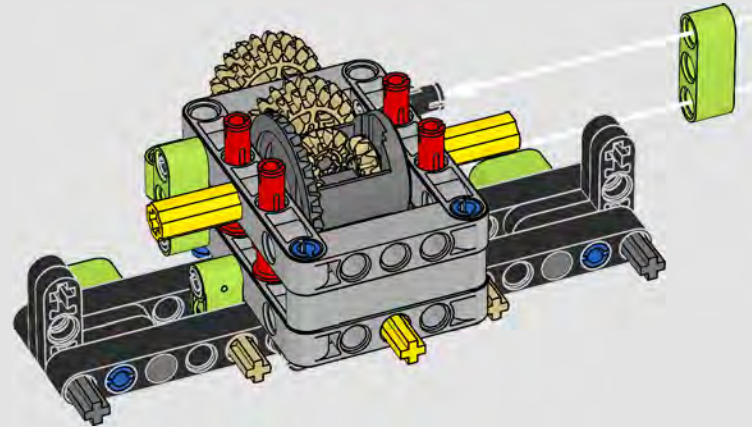

224

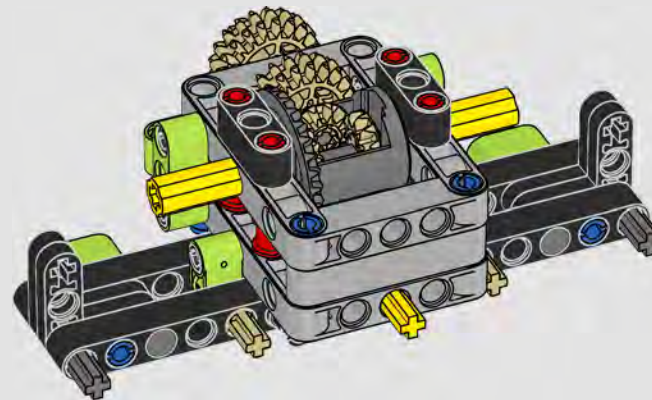

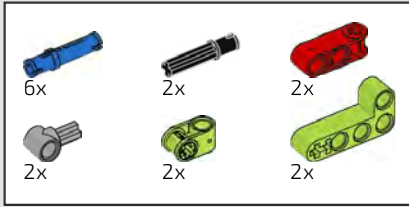

225

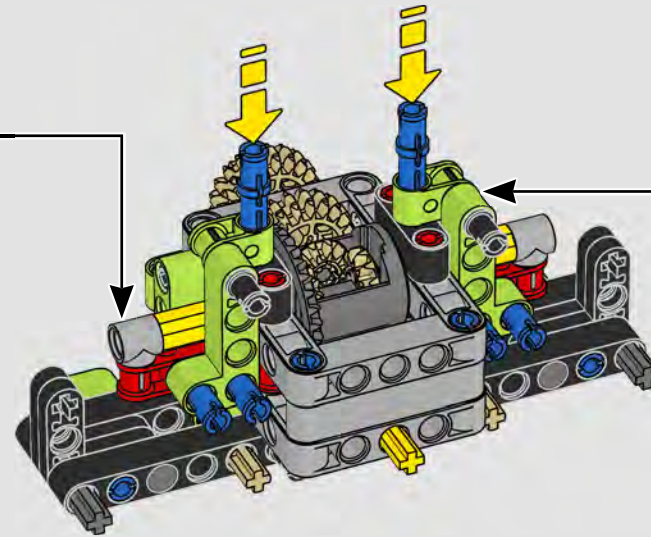
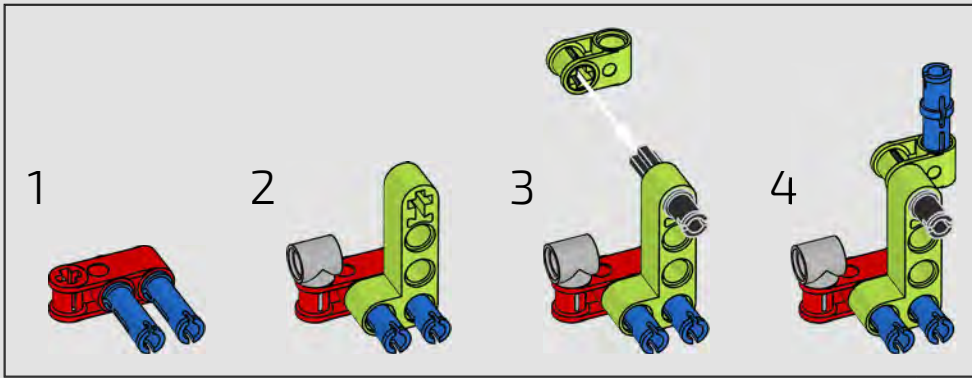
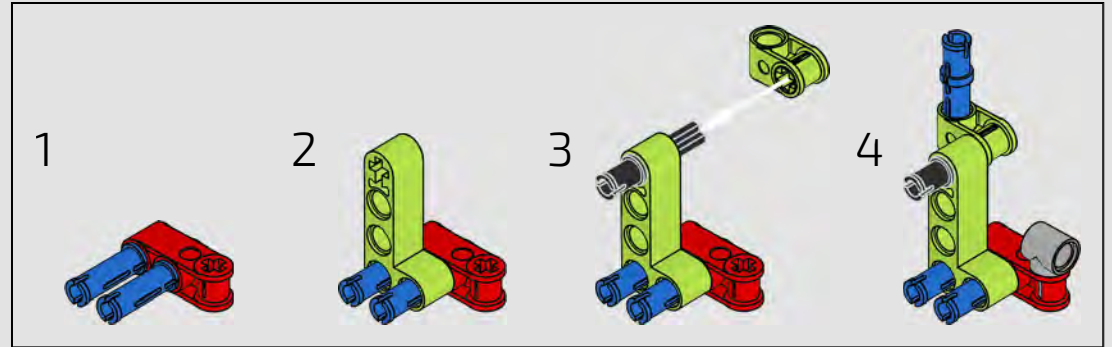

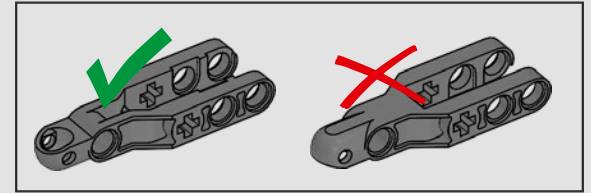
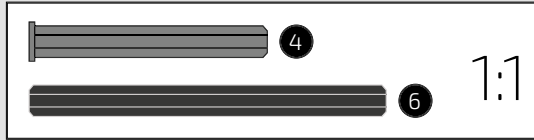
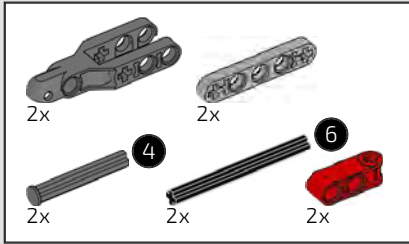

226

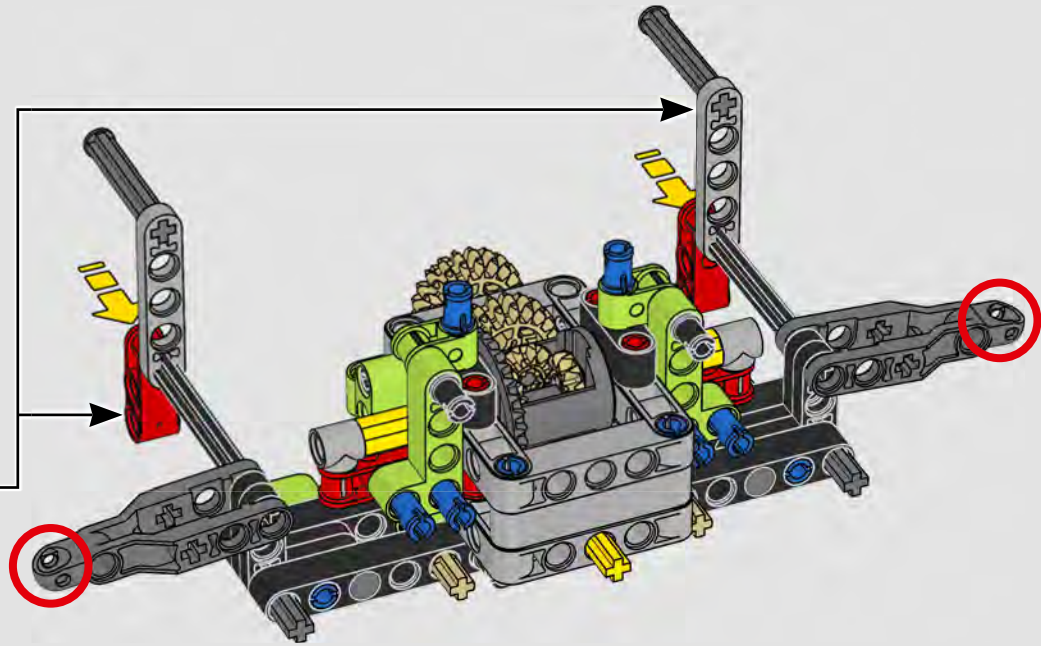
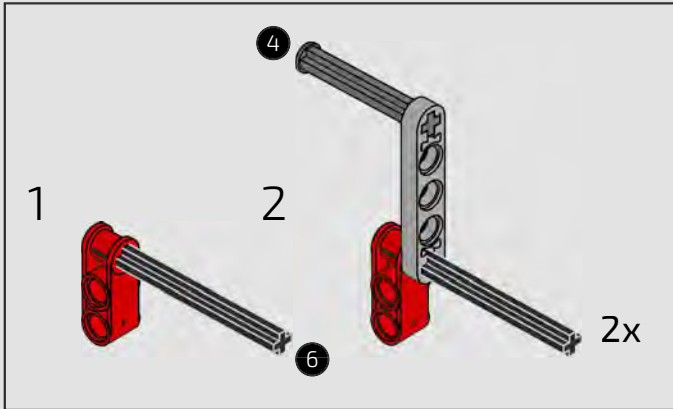

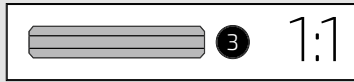
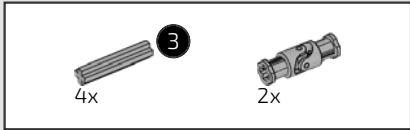

227

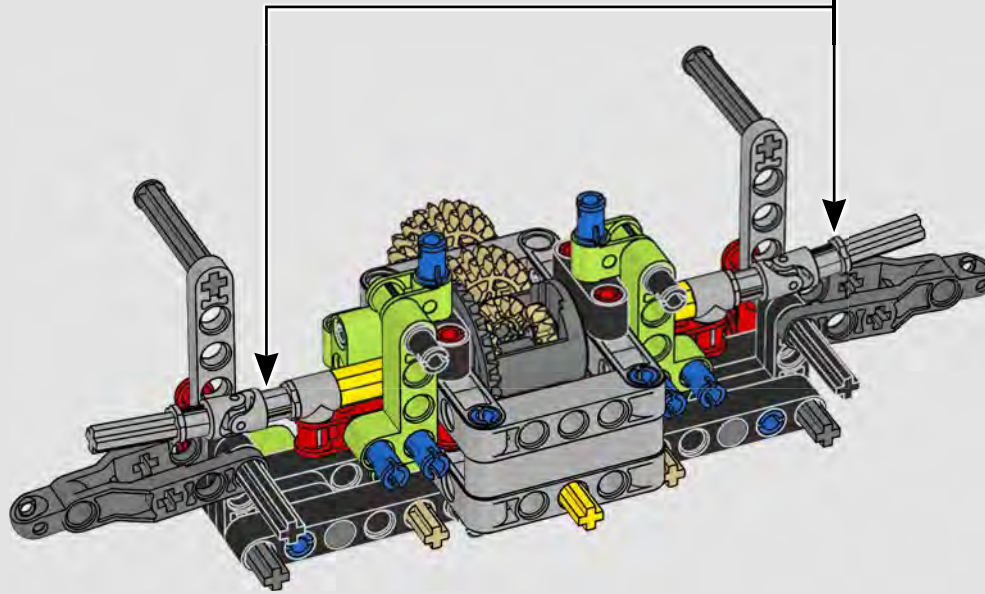
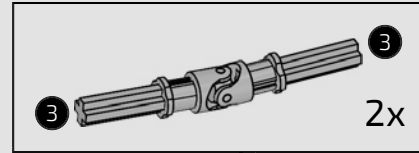

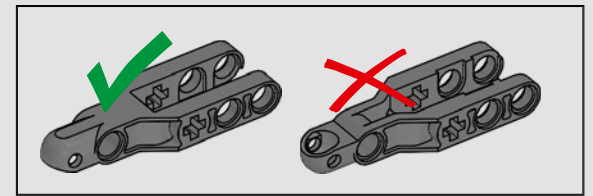
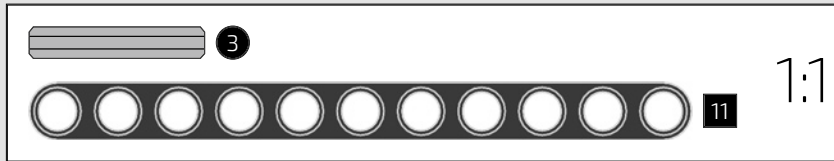
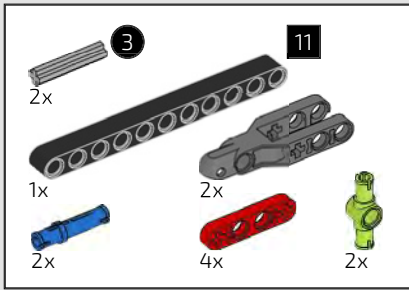

228

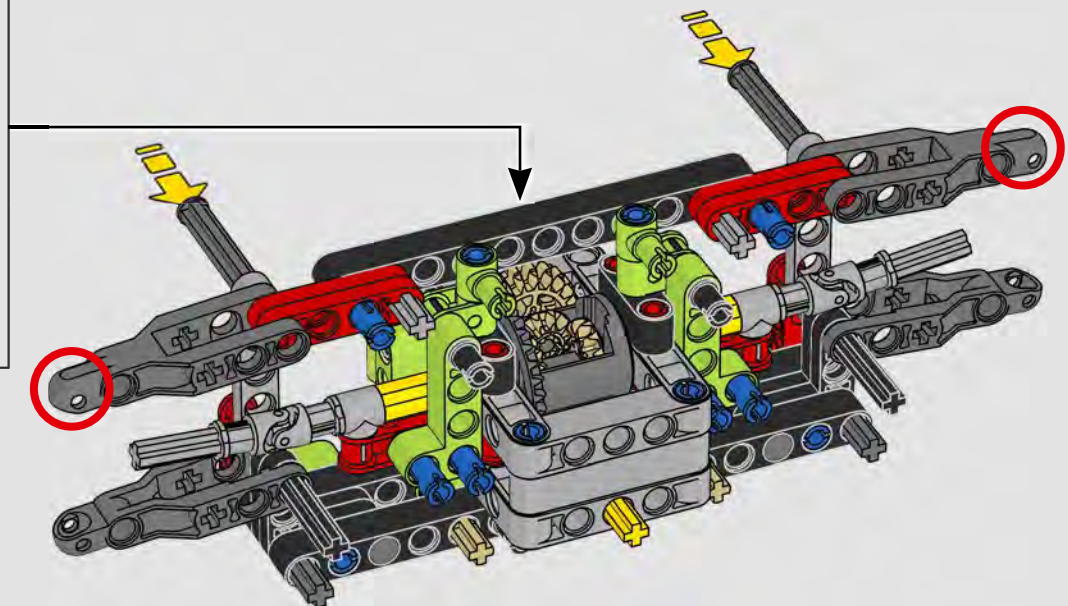
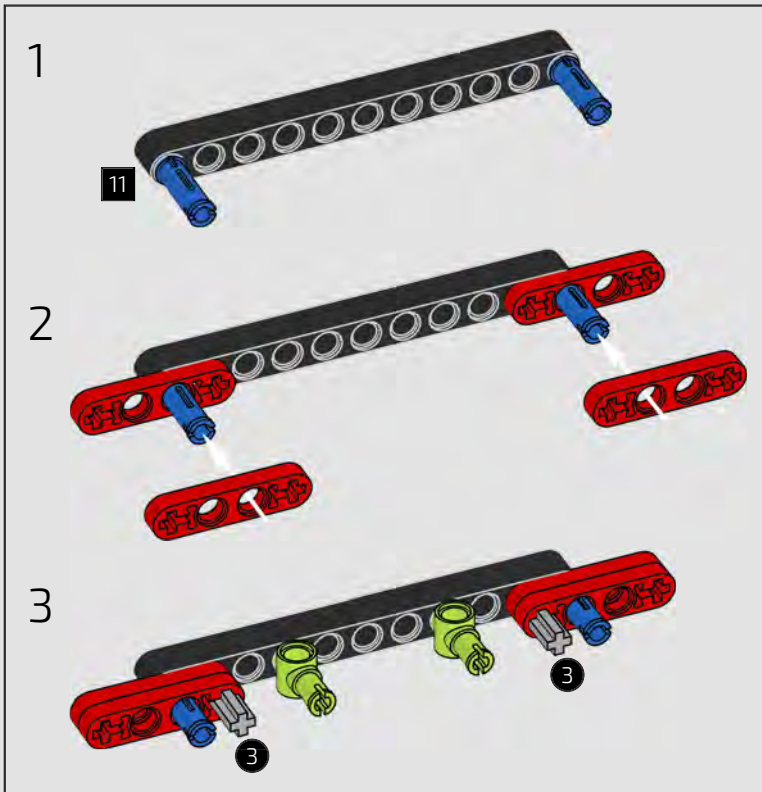

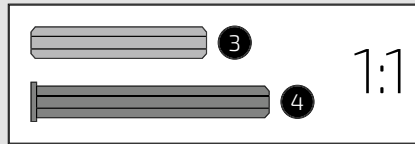
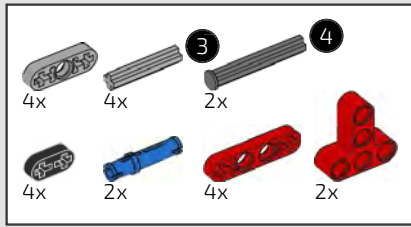

229

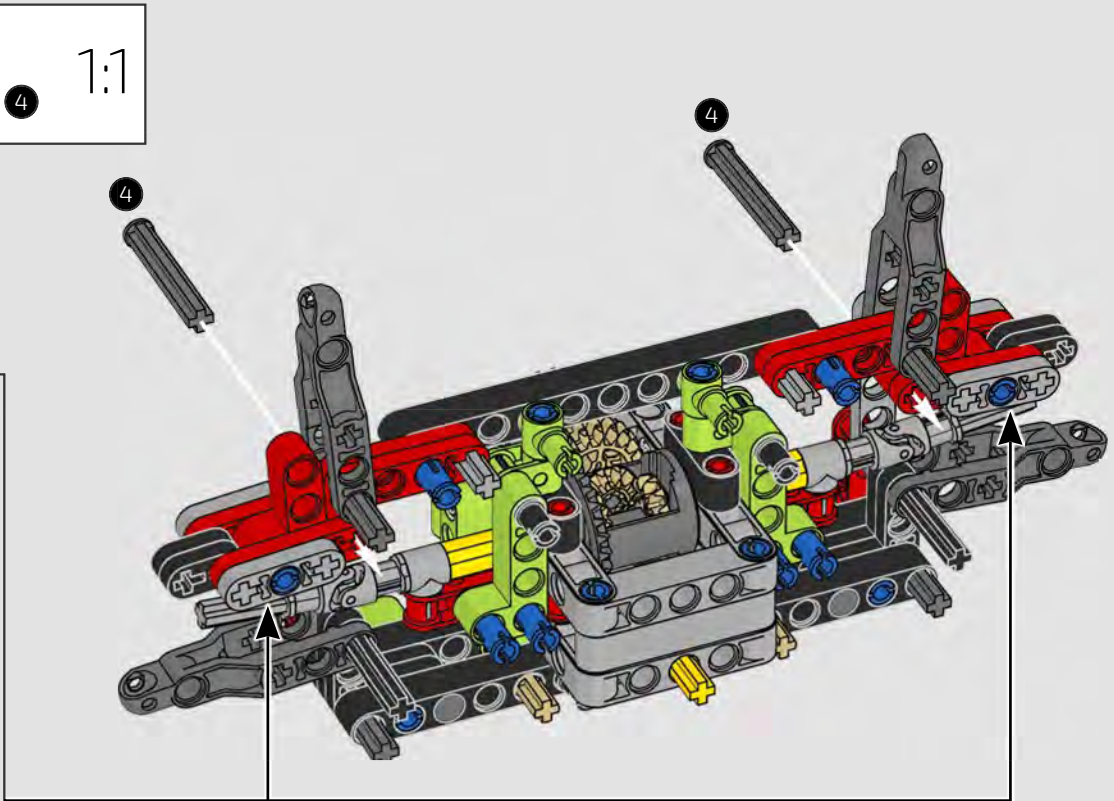
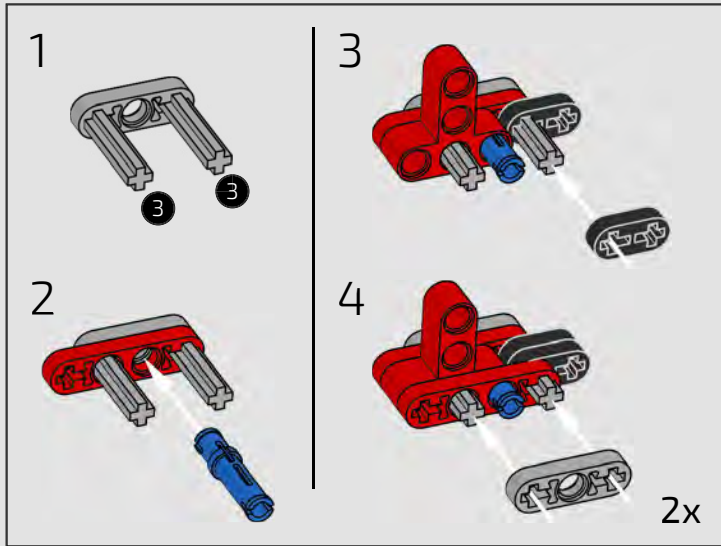

230

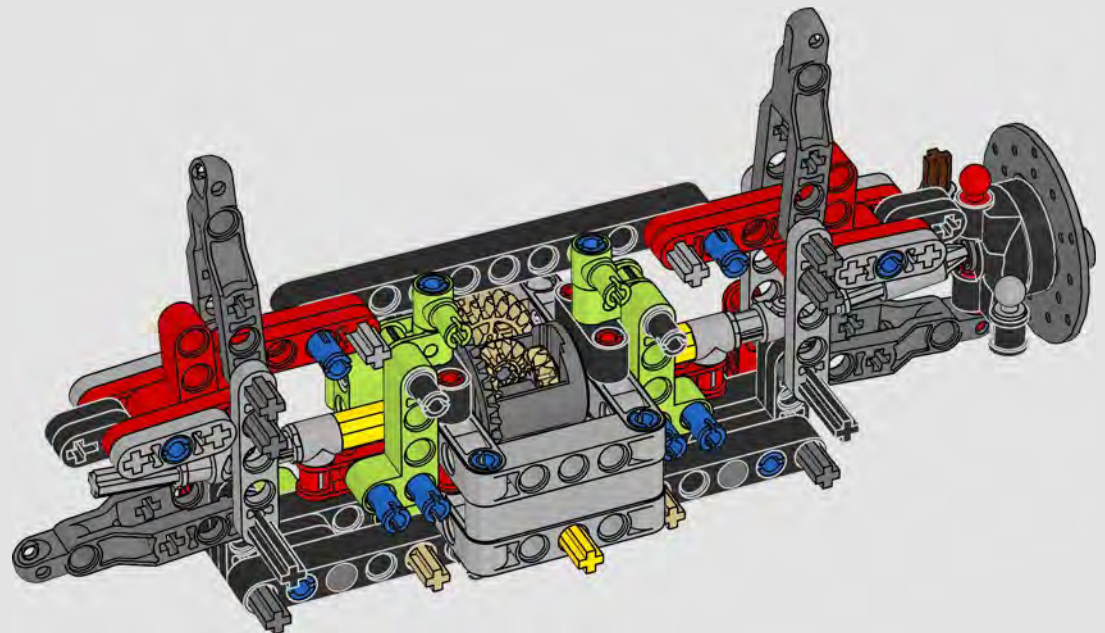

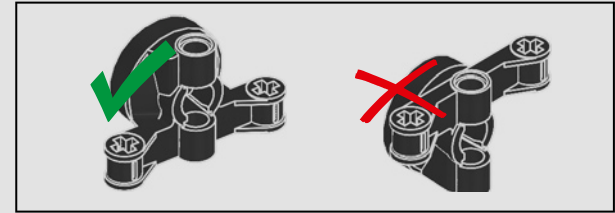
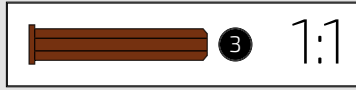
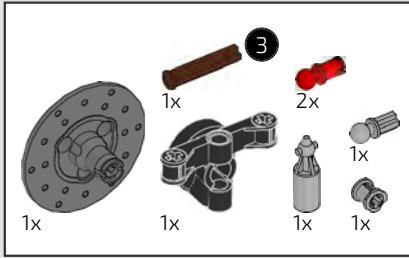

231

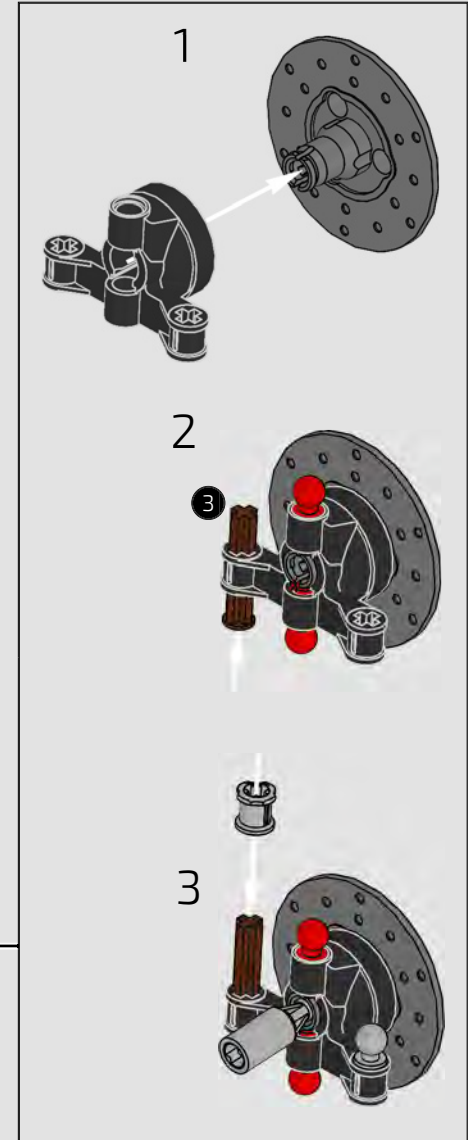
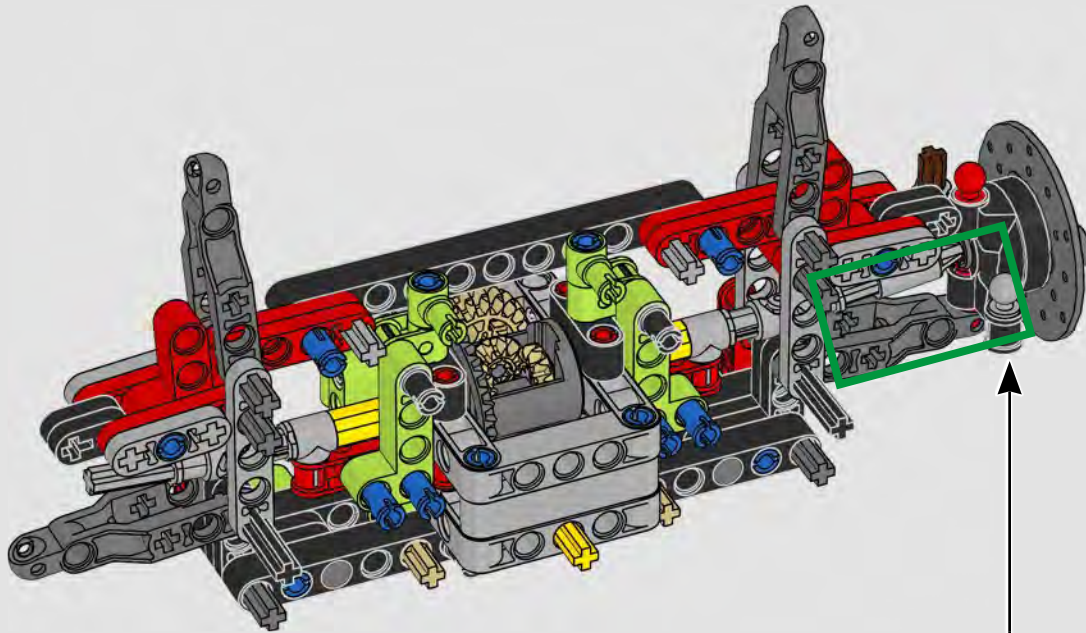

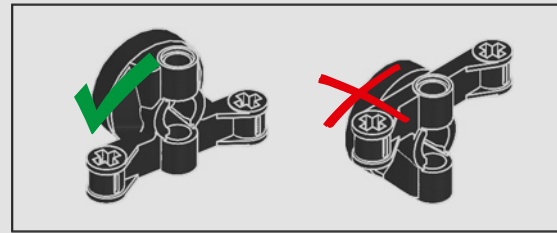
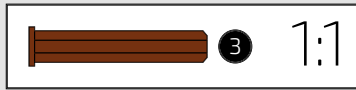
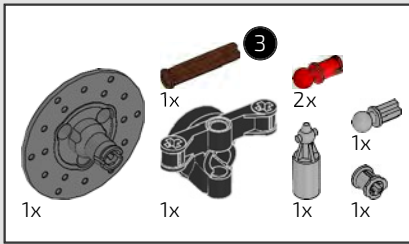

232

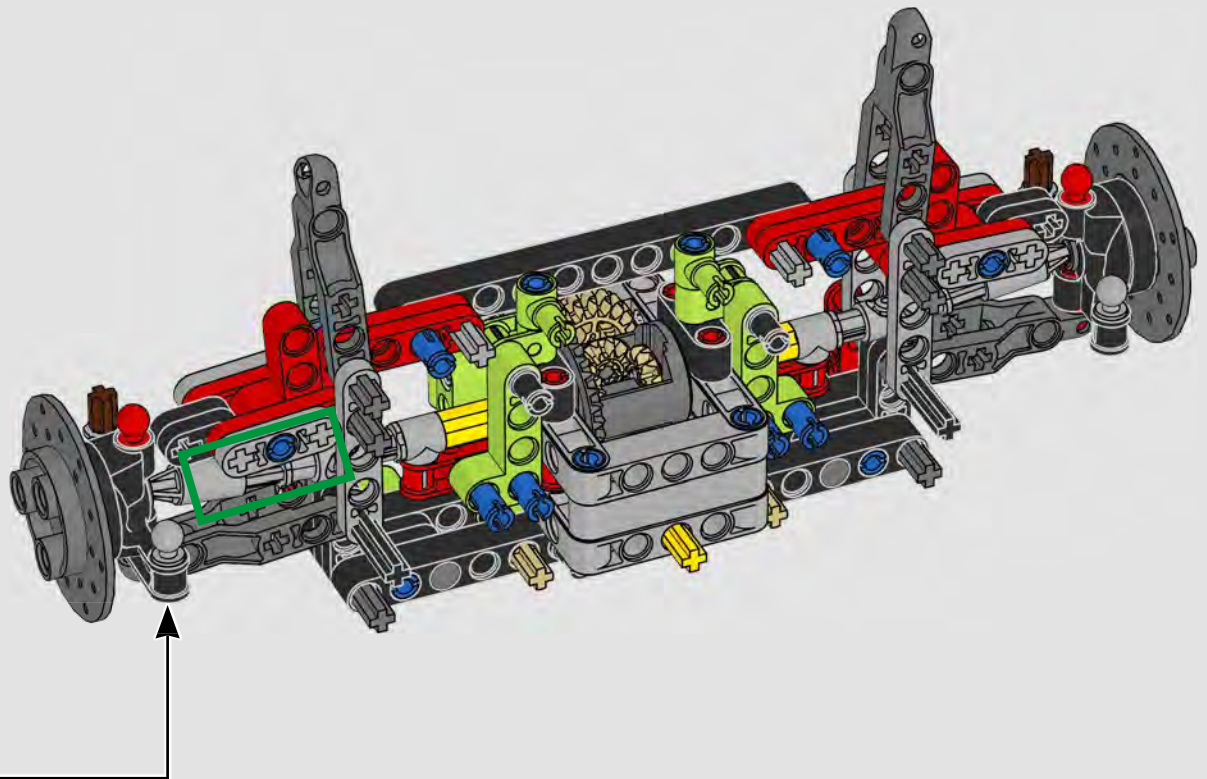
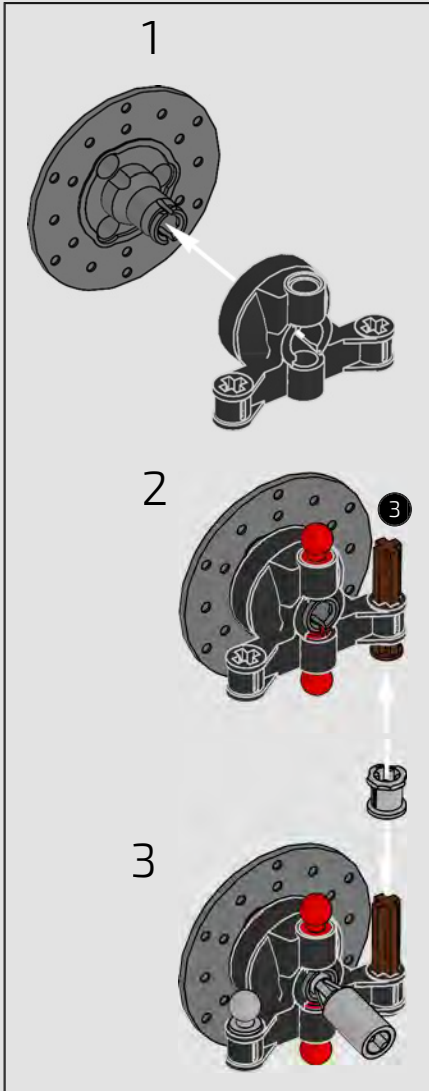

233

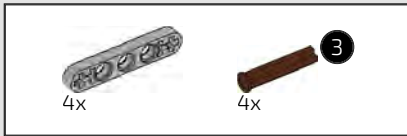
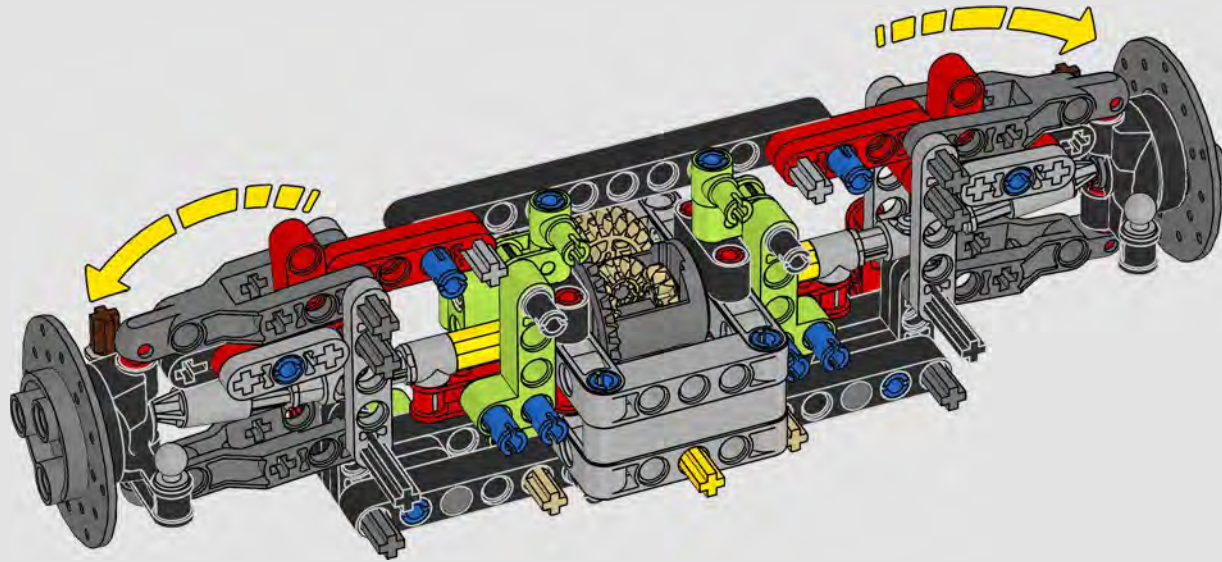

234

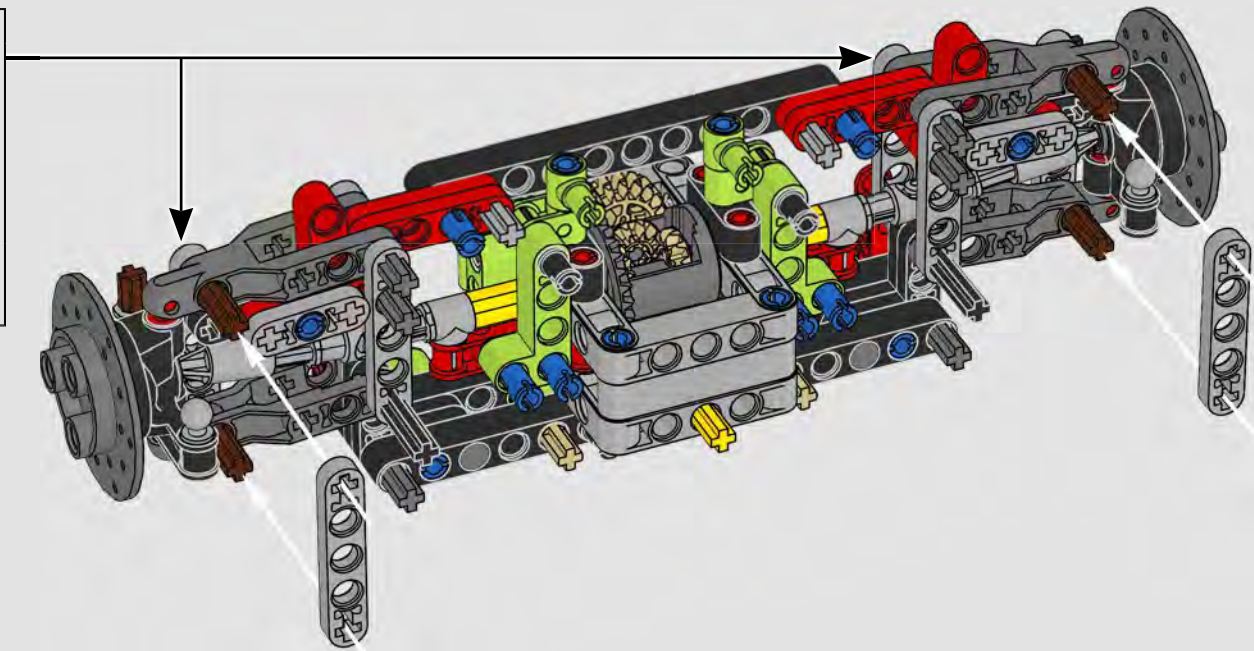
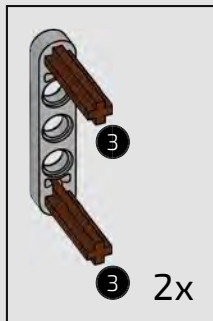

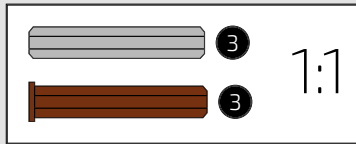

235

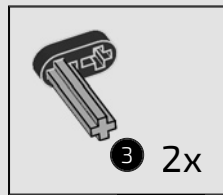
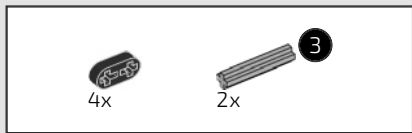
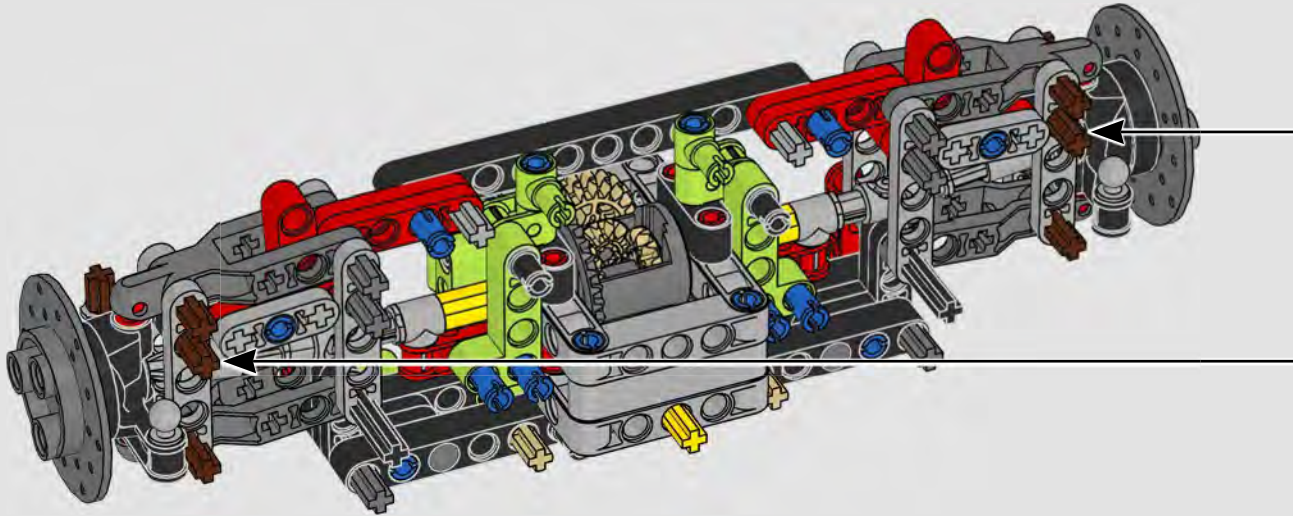

236

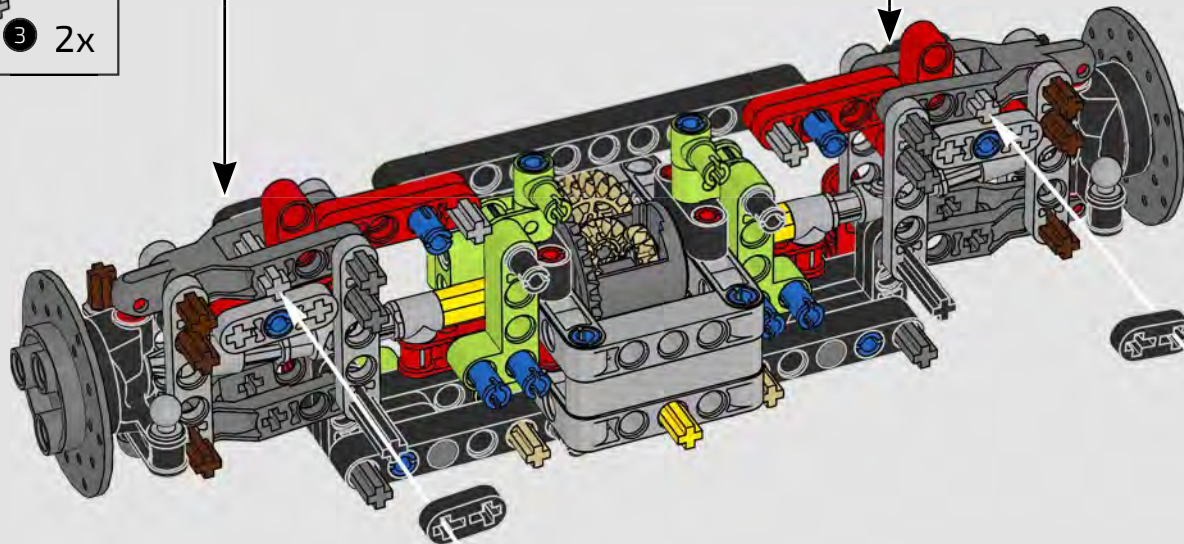

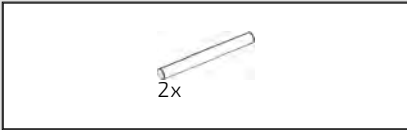

237

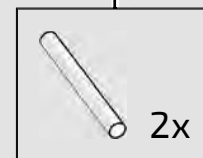
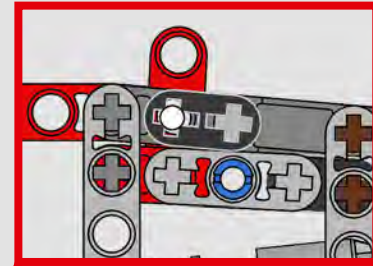
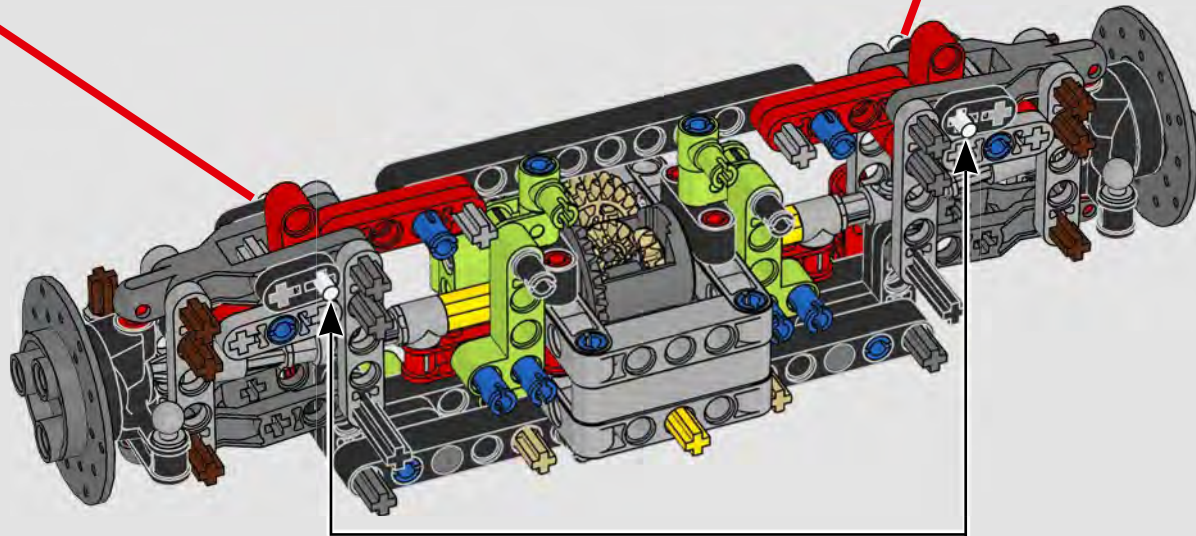
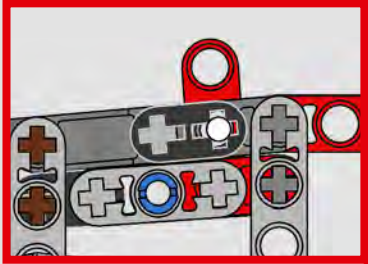

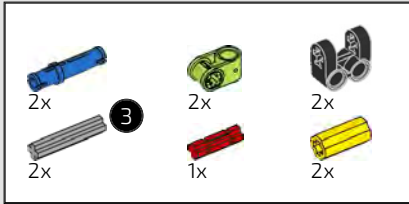

238

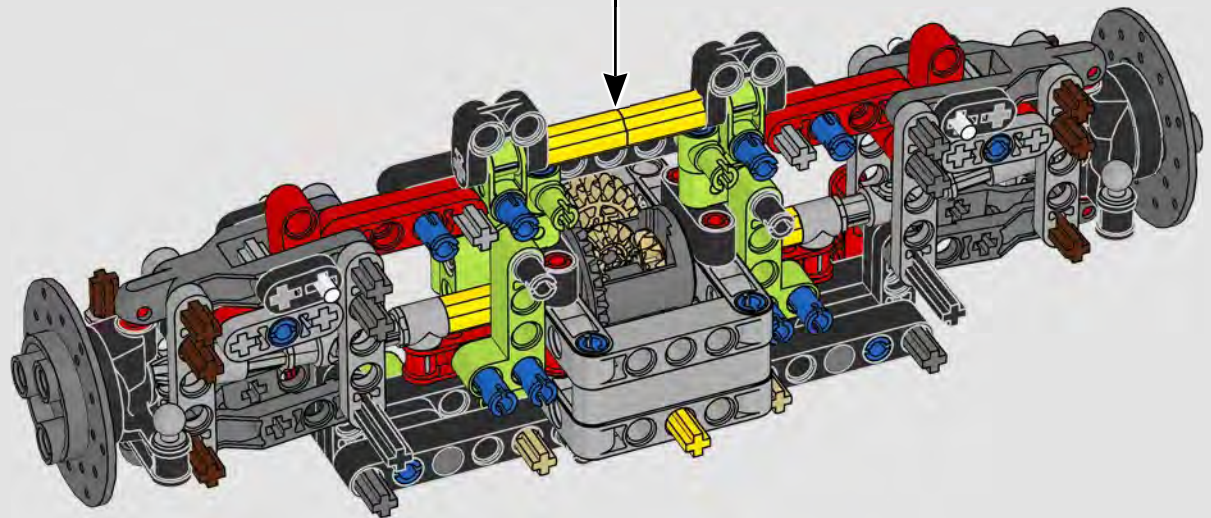
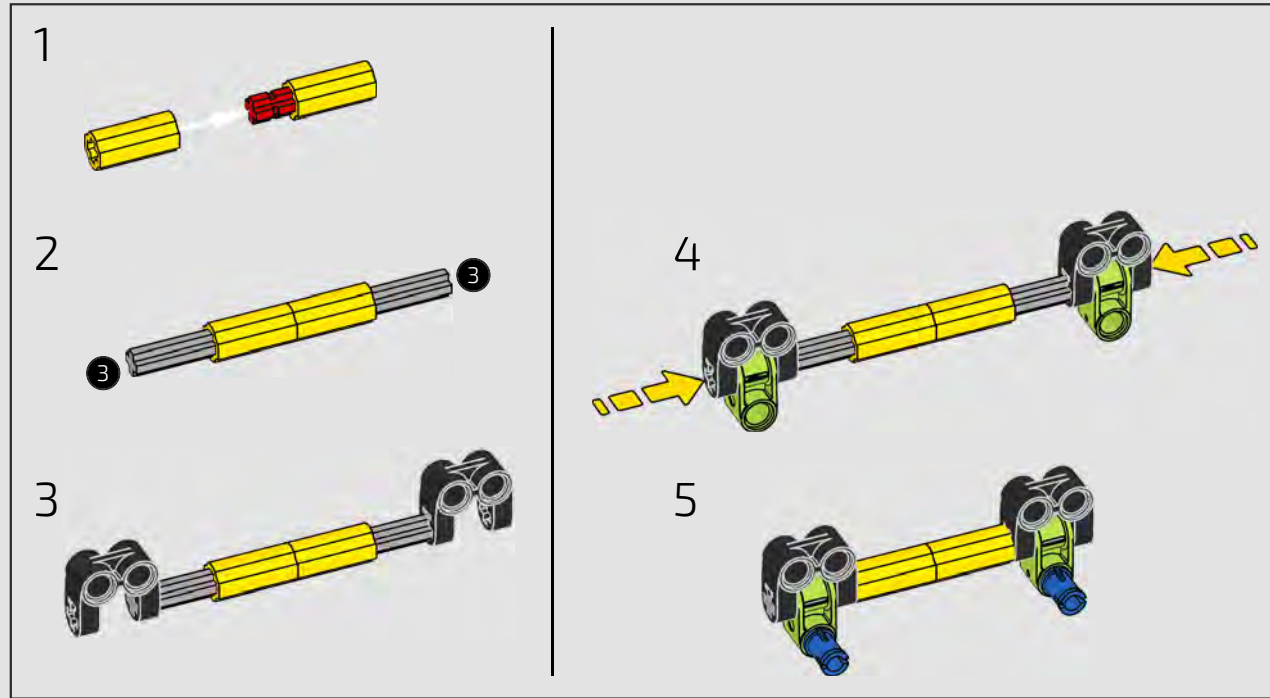
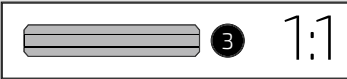

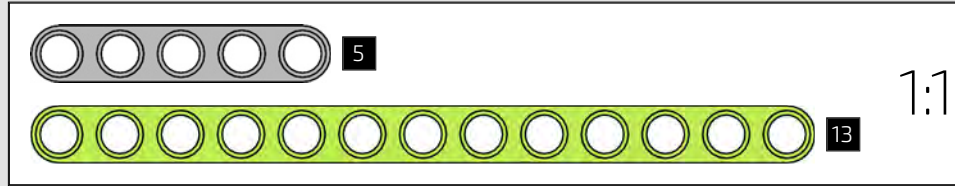
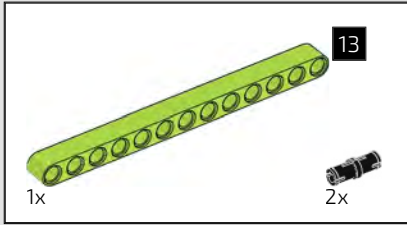

239

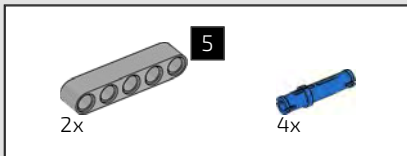
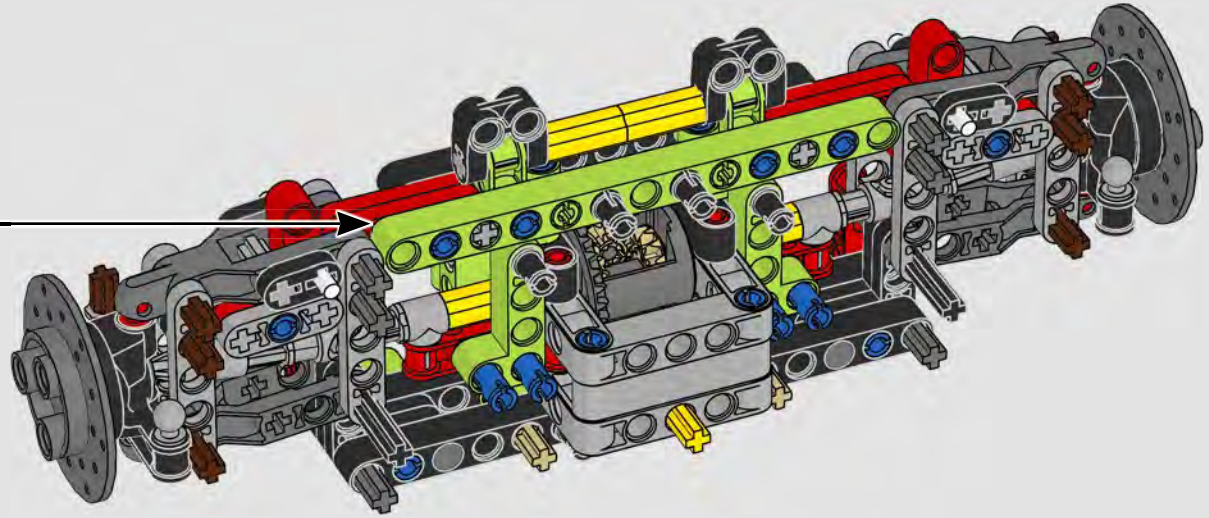
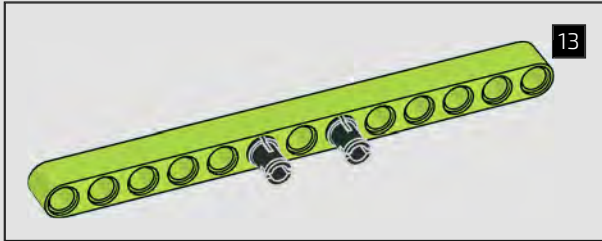

240

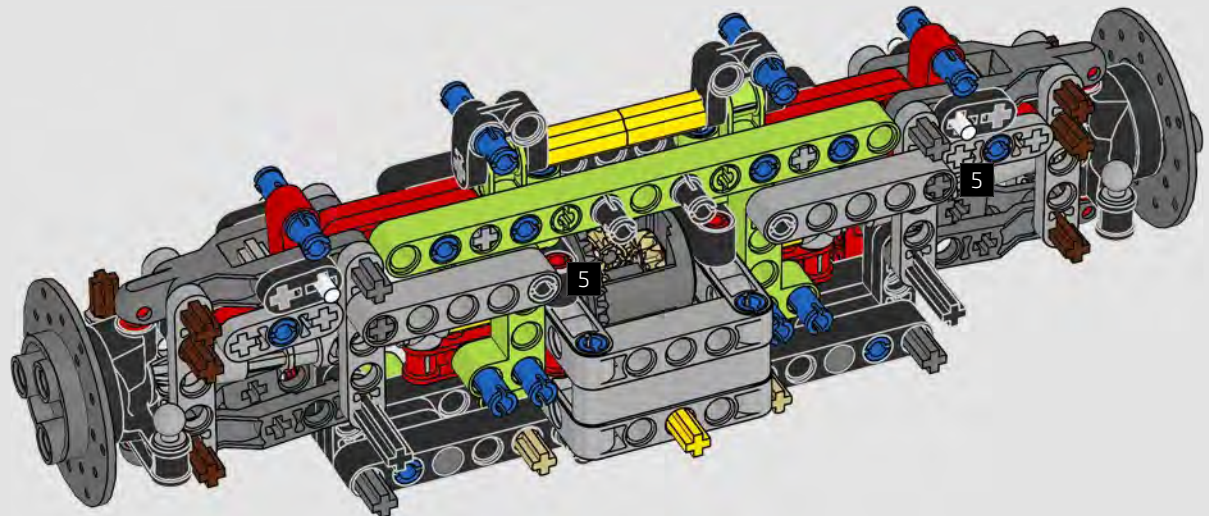

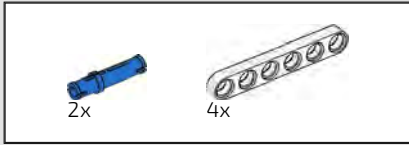

241

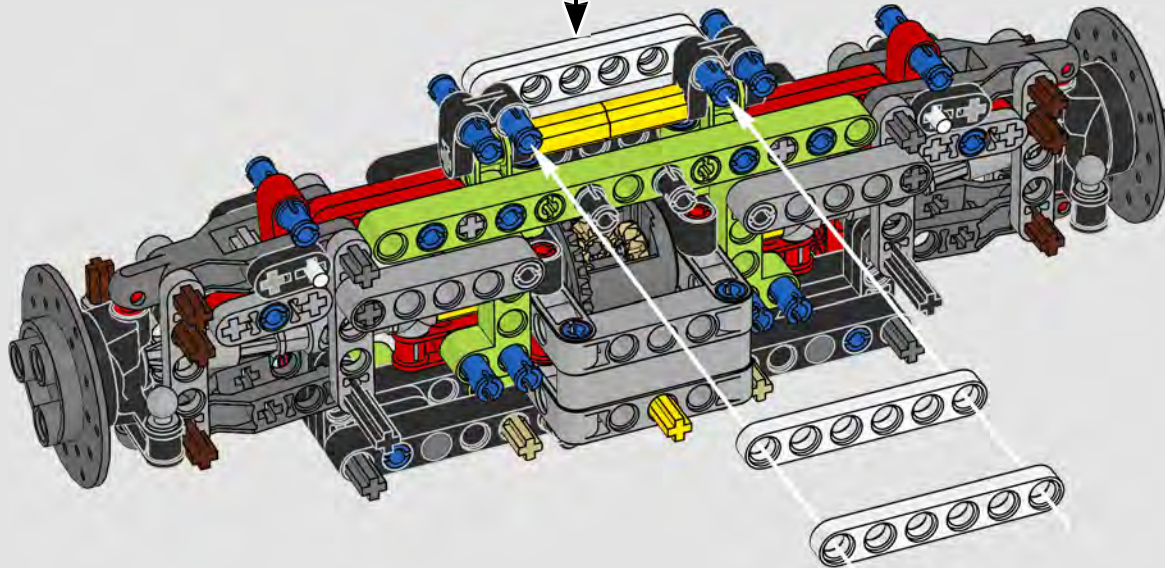
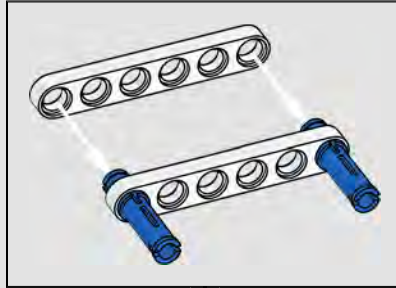

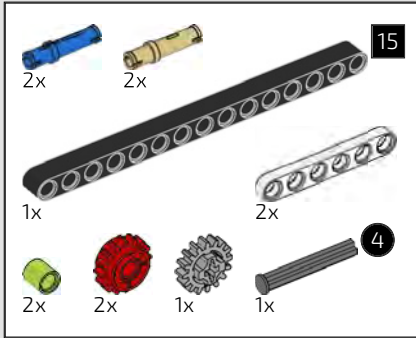

242

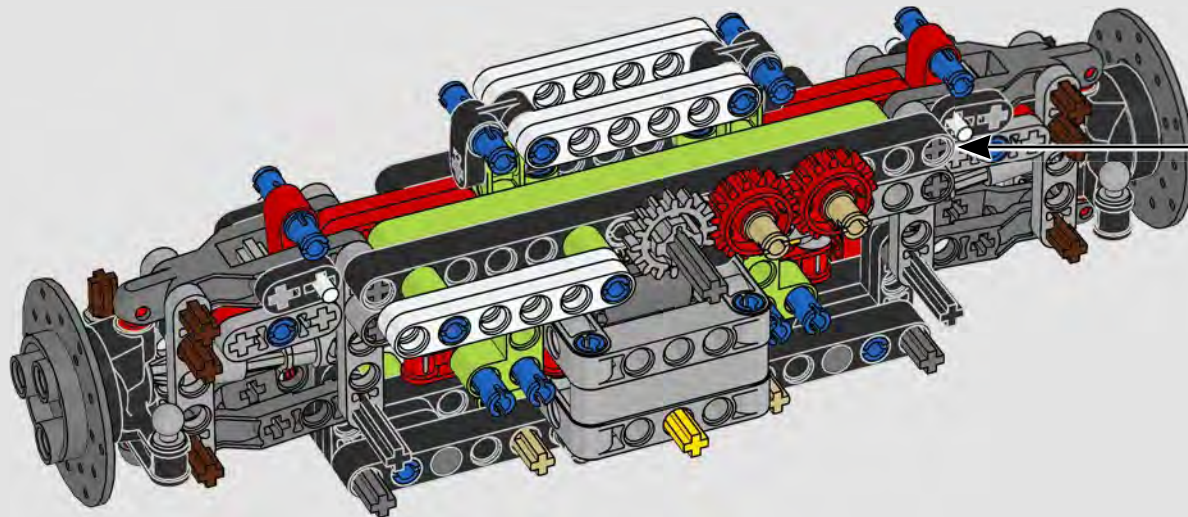
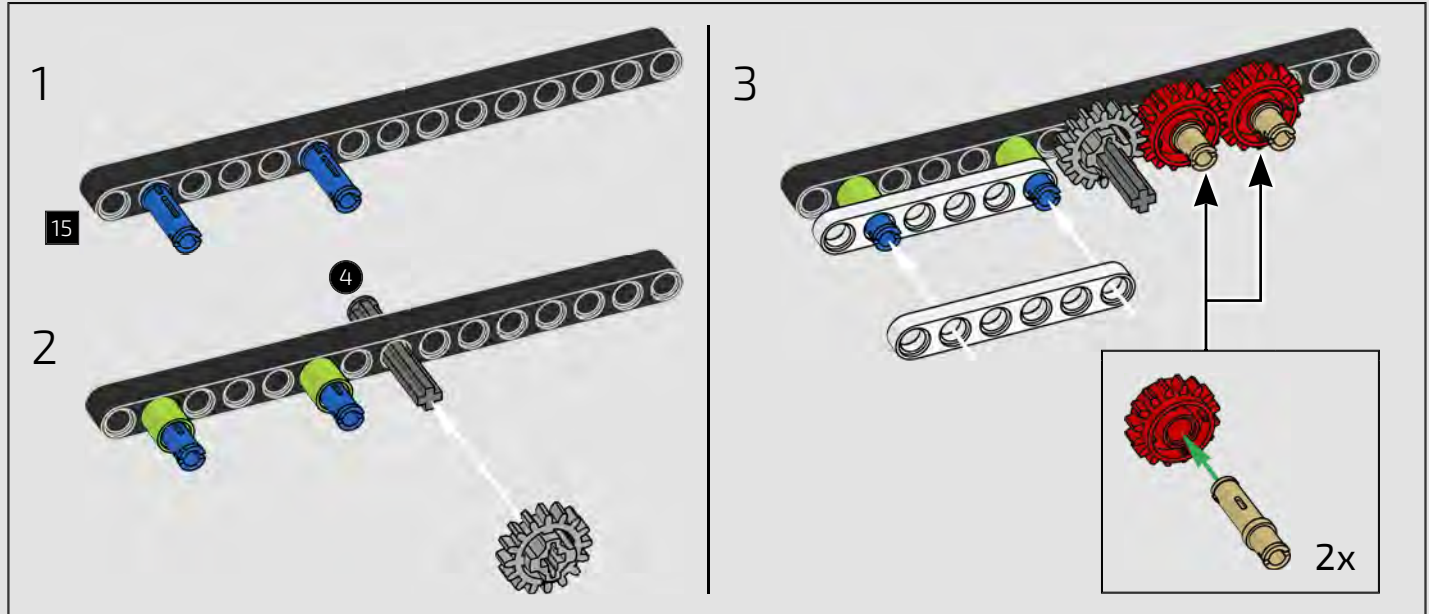
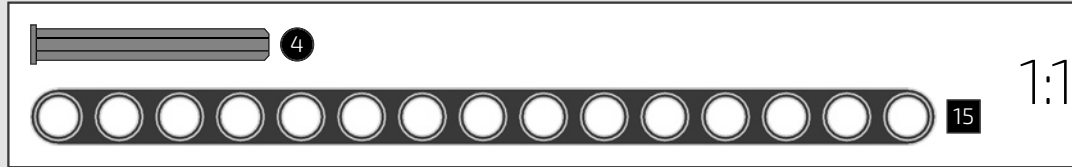

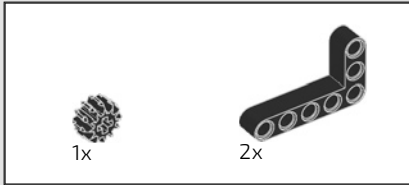

243

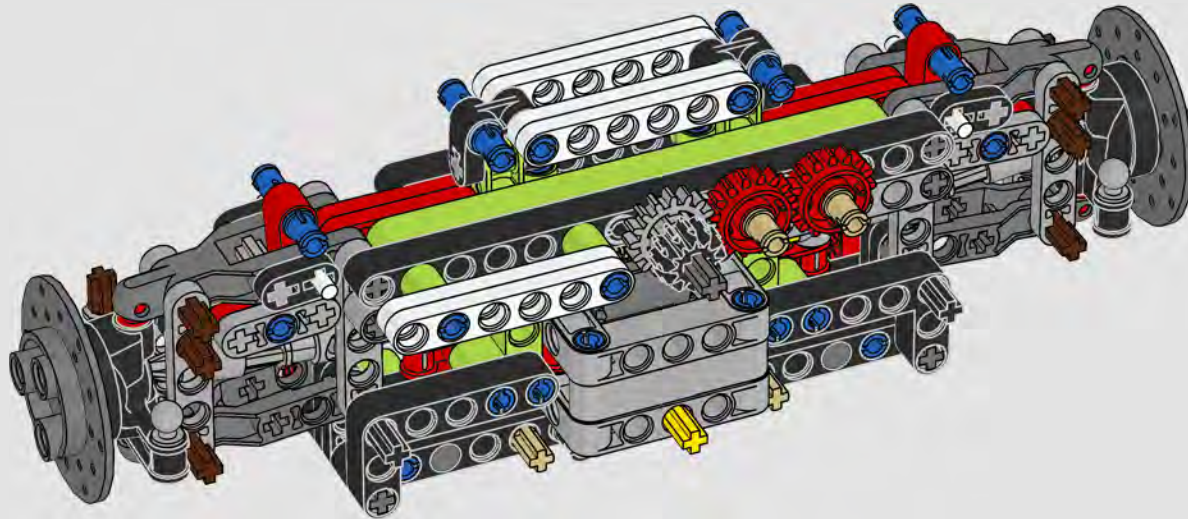

244

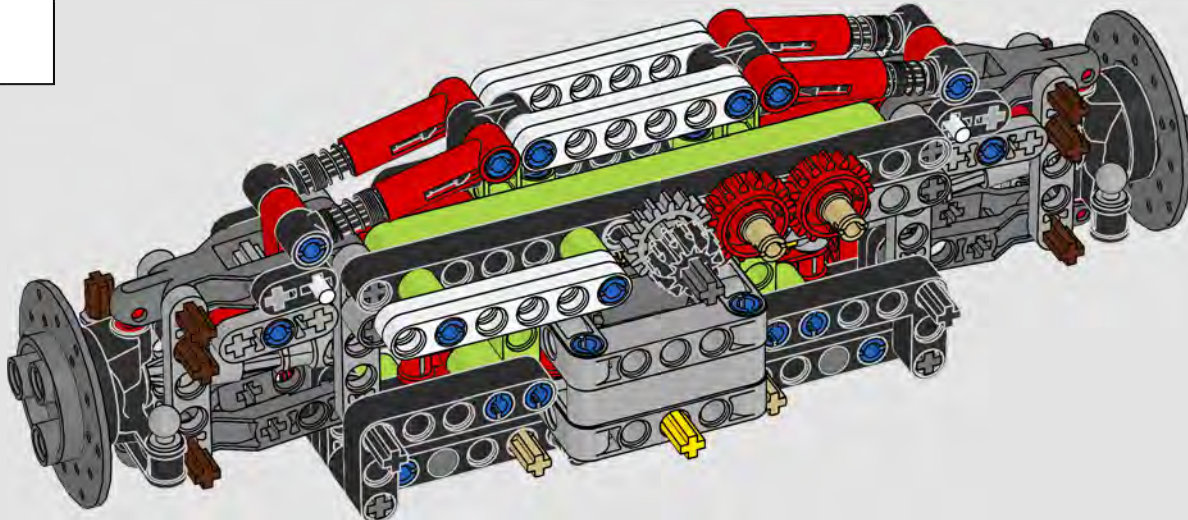

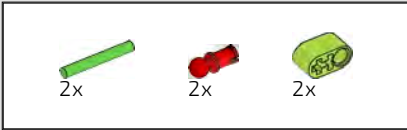

245

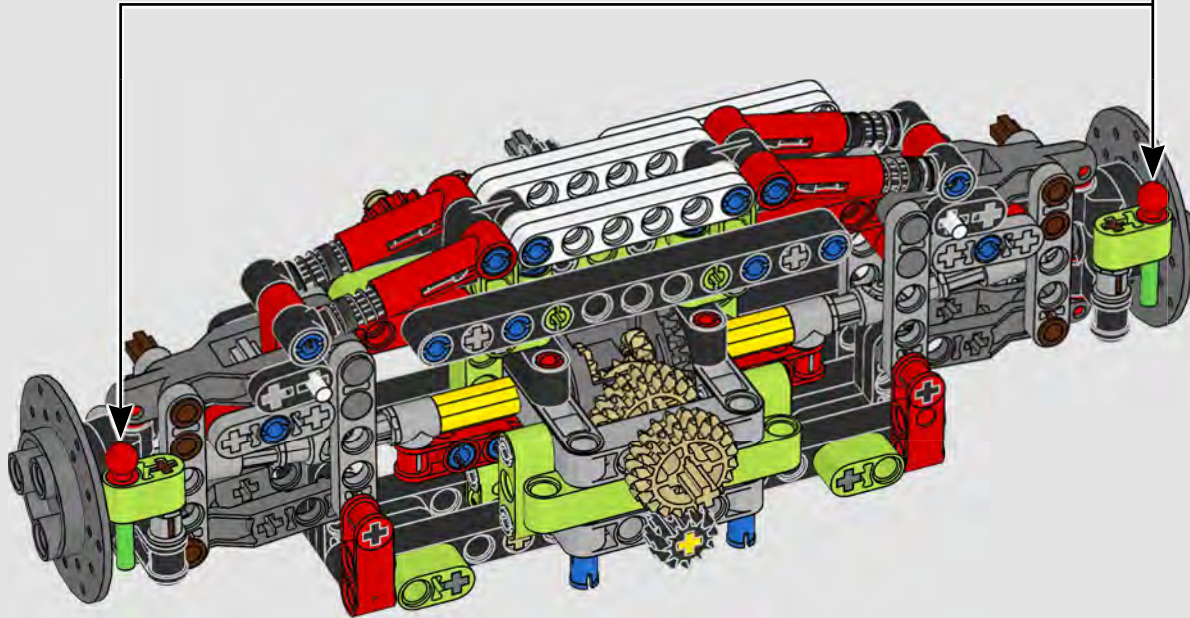
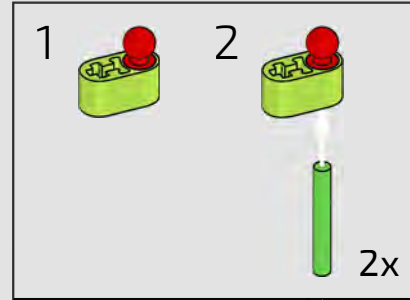

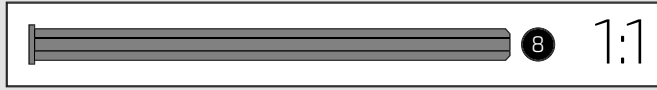
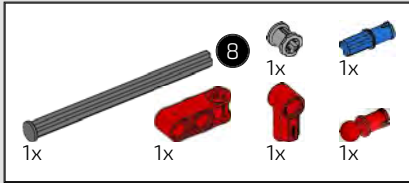

246

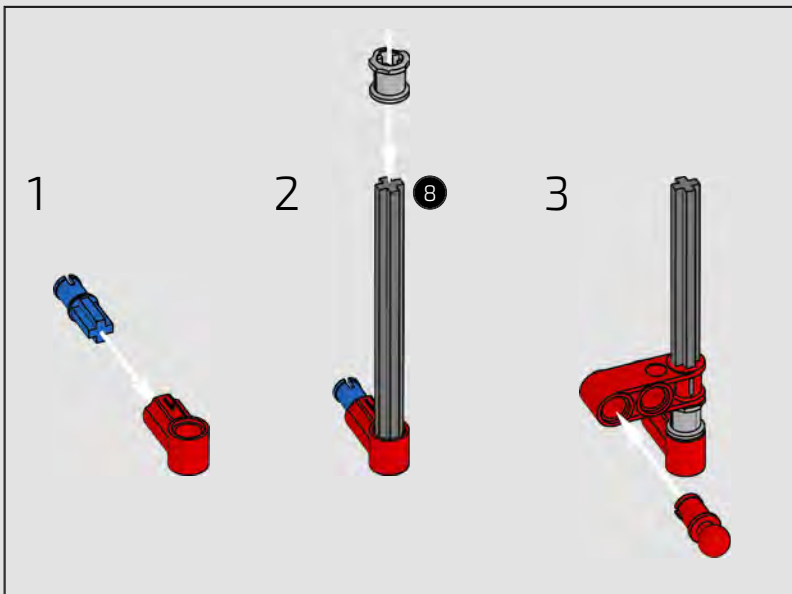
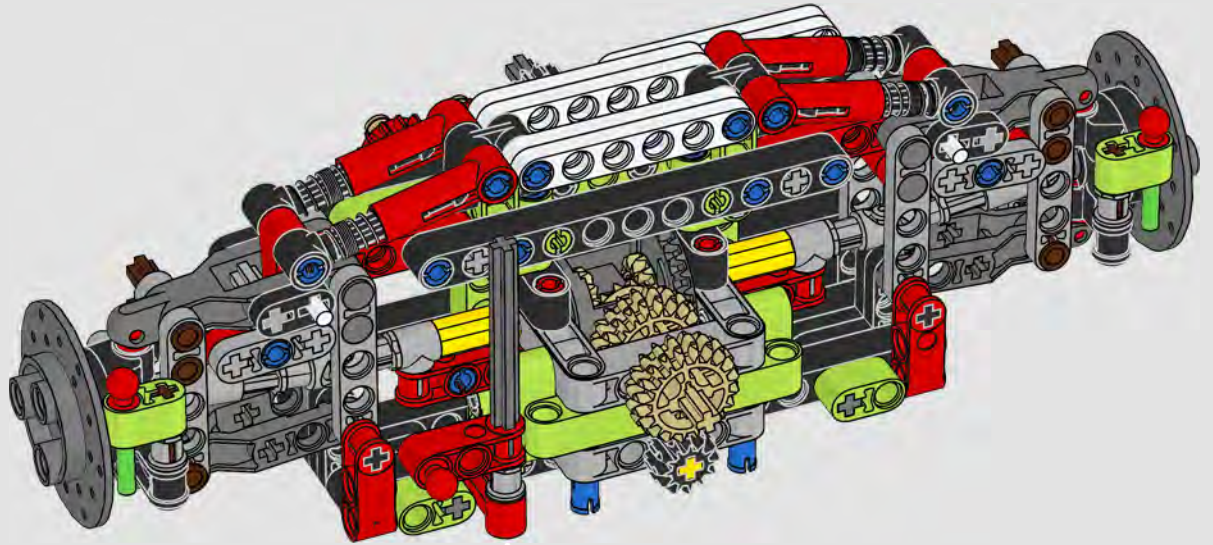

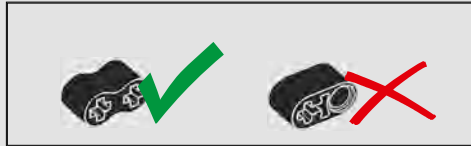
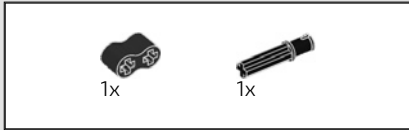

247

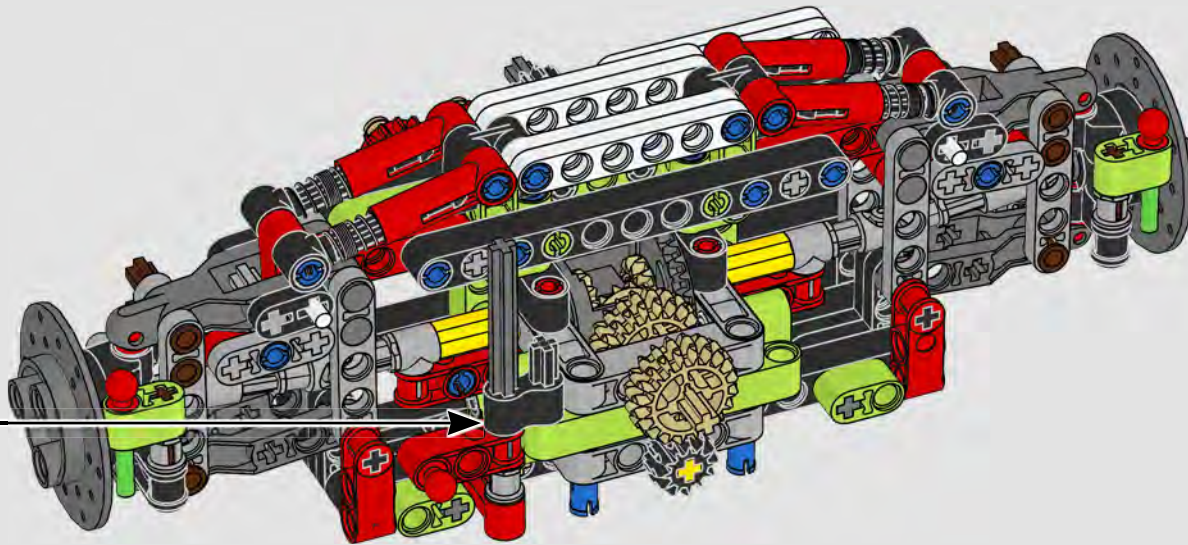
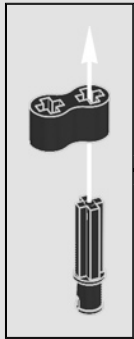

248

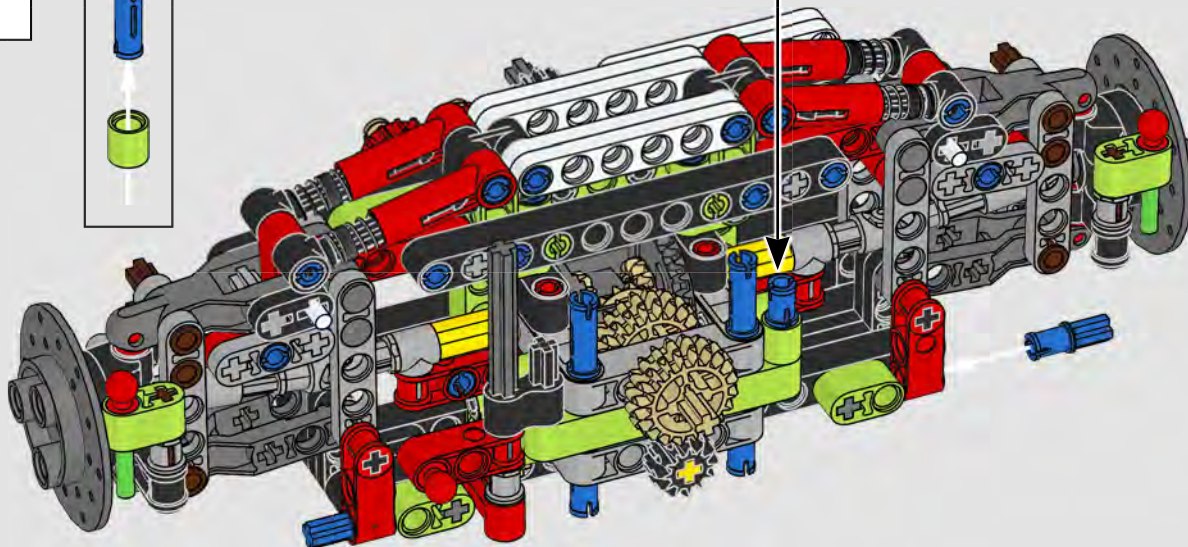

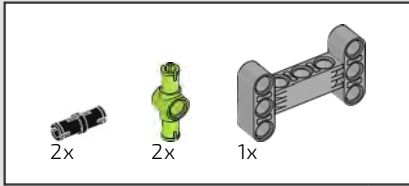

249

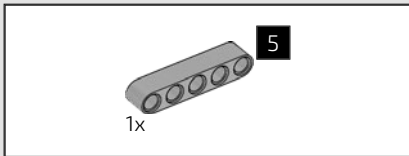
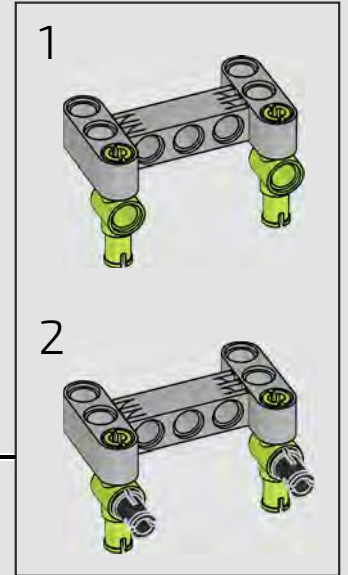
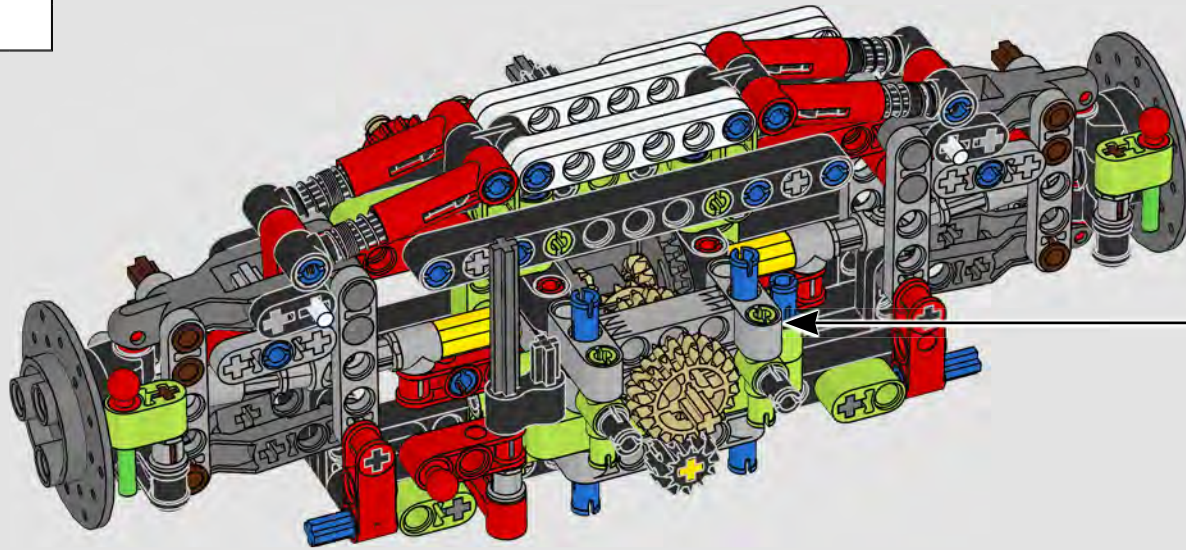

250

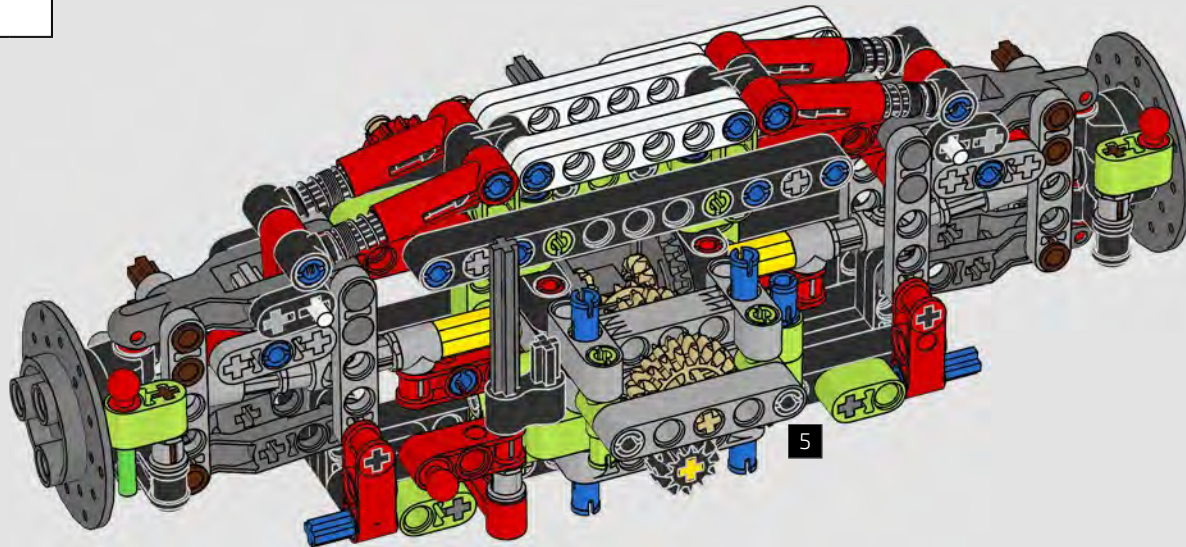
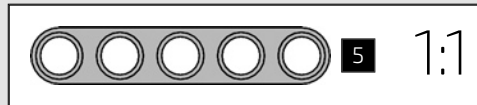

251

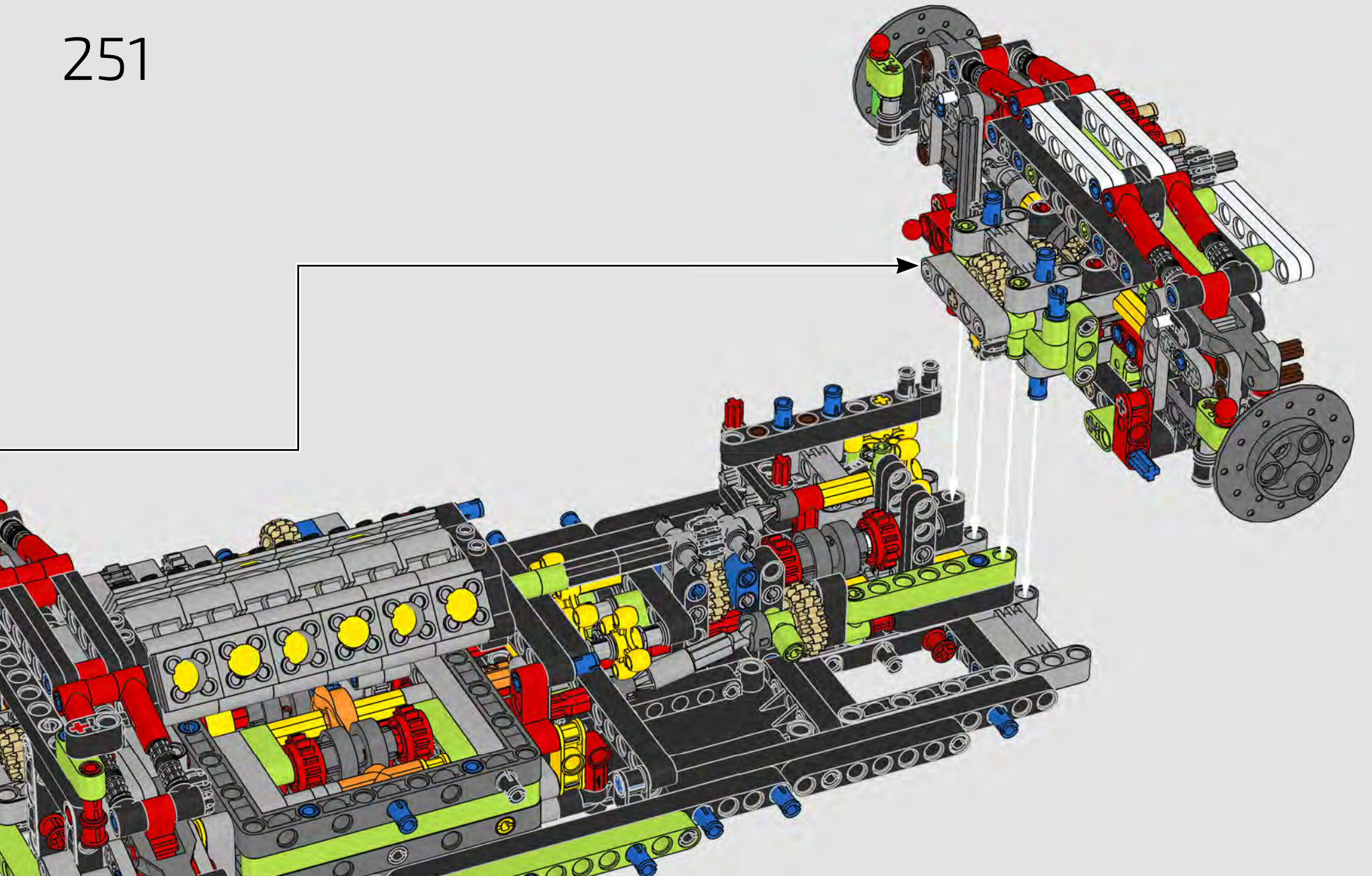

252

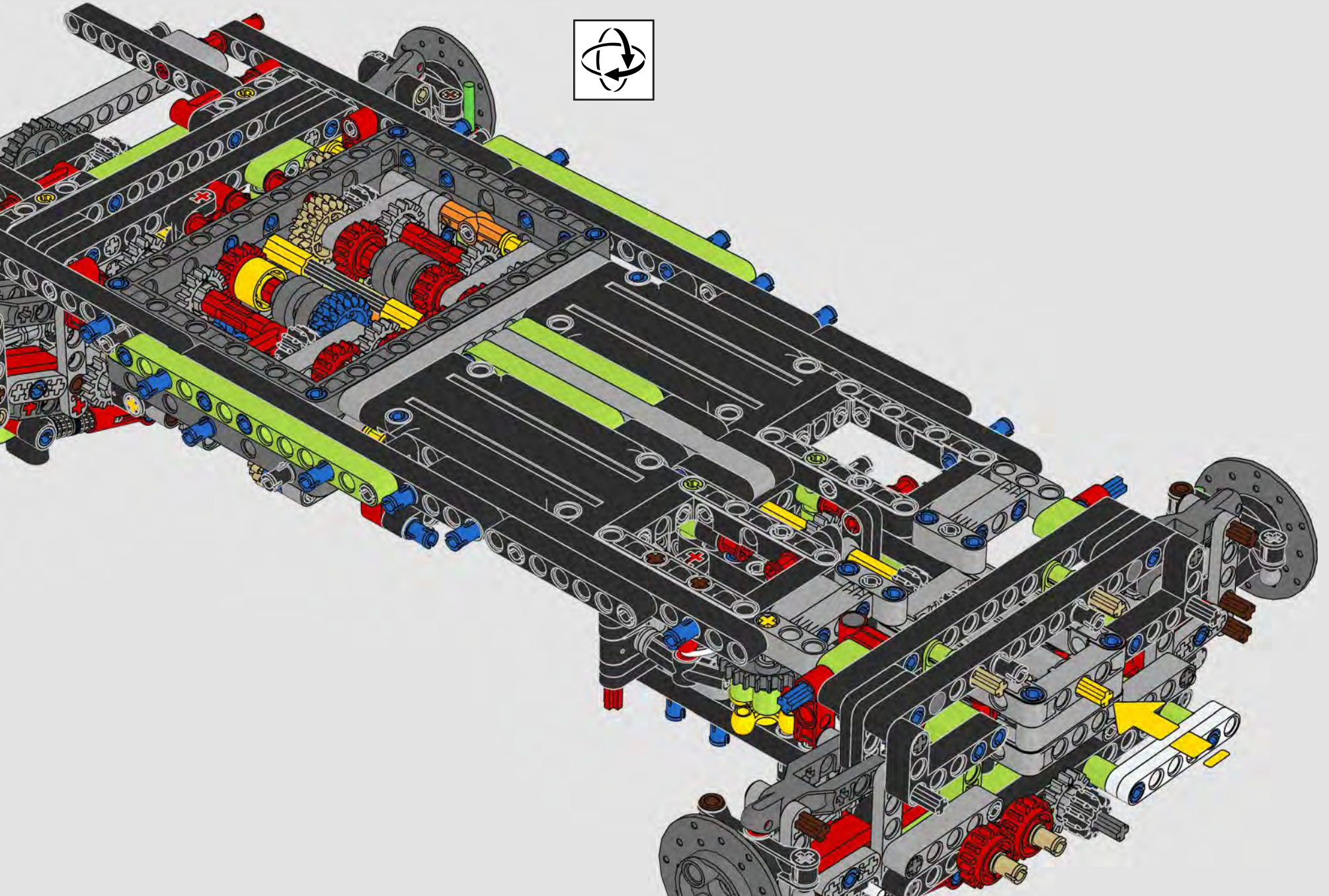



253

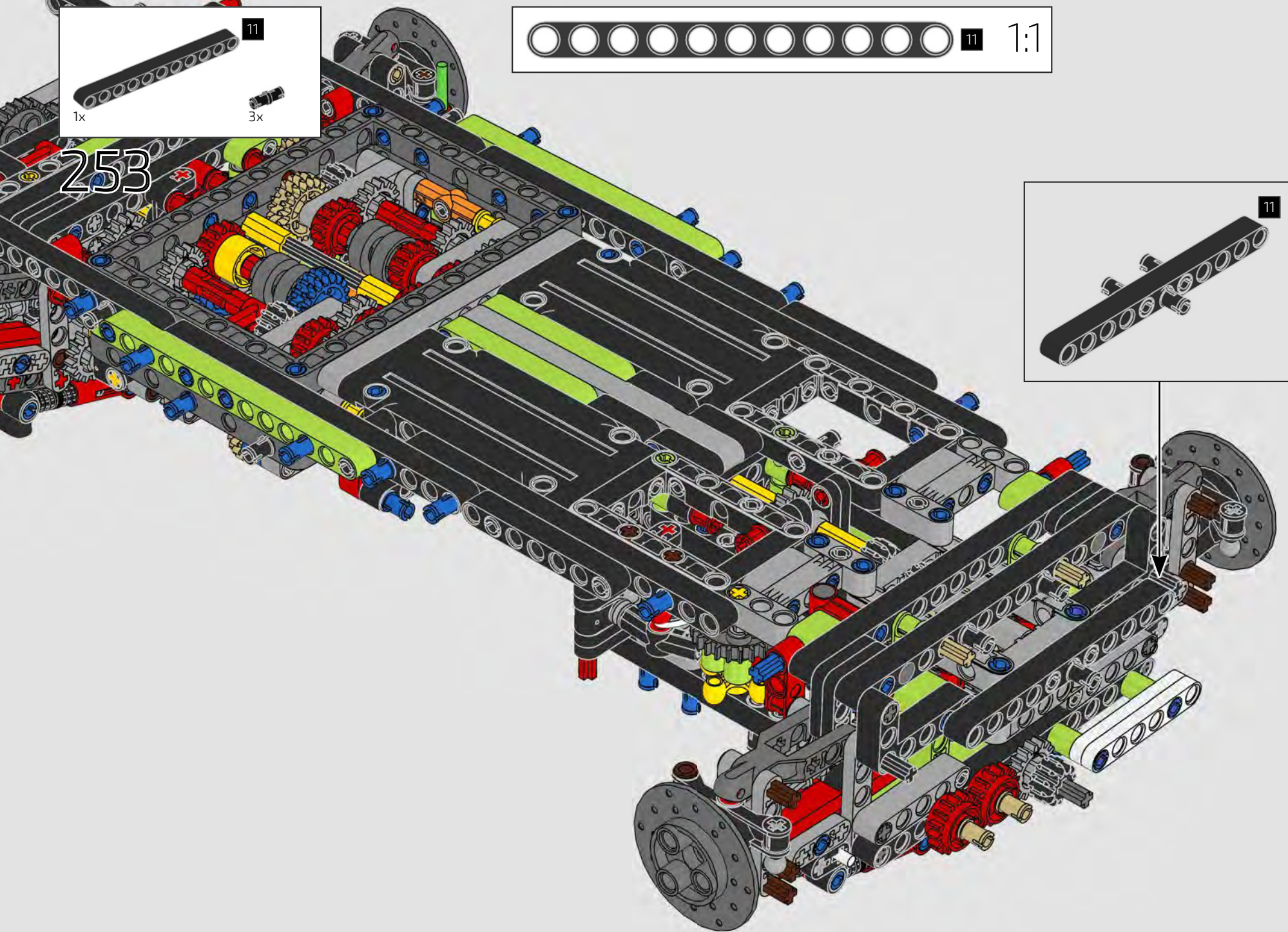
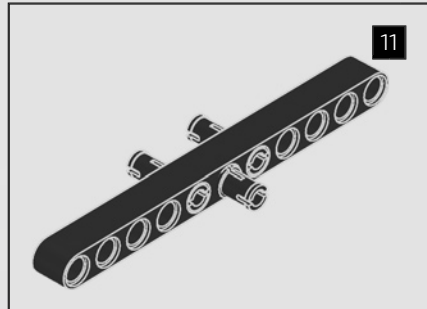

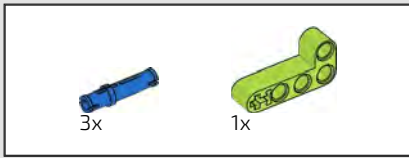

254

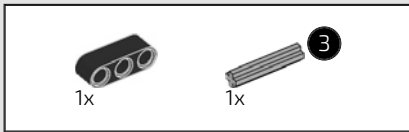
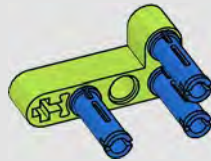

255

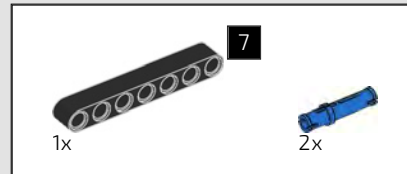
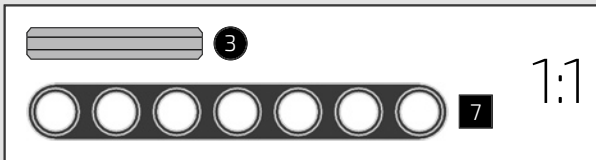
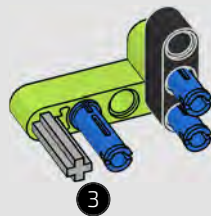

256

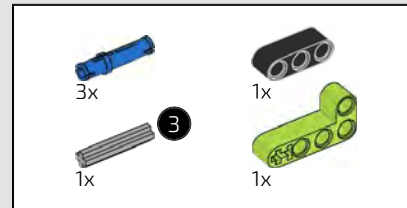
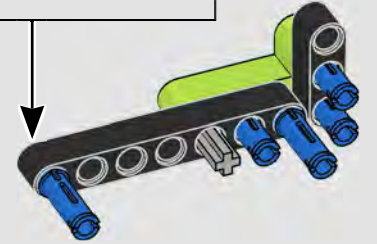

257

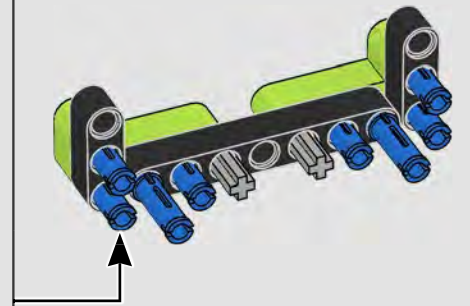
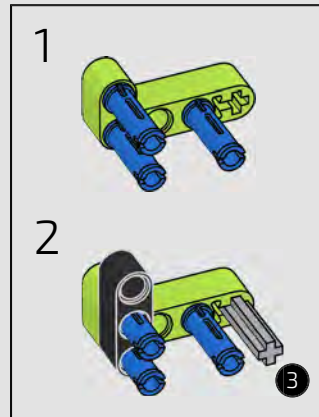

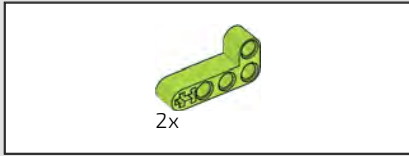

258

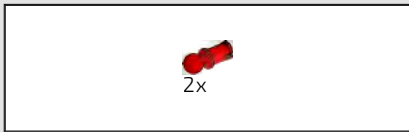
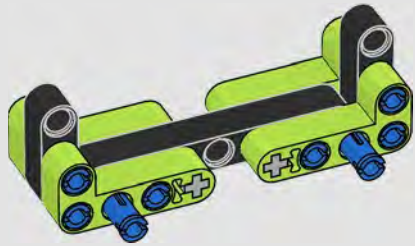

259

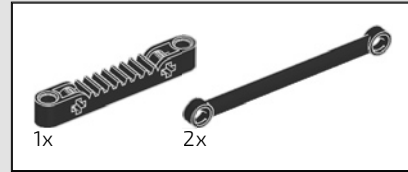
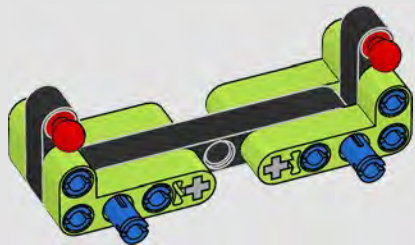

260

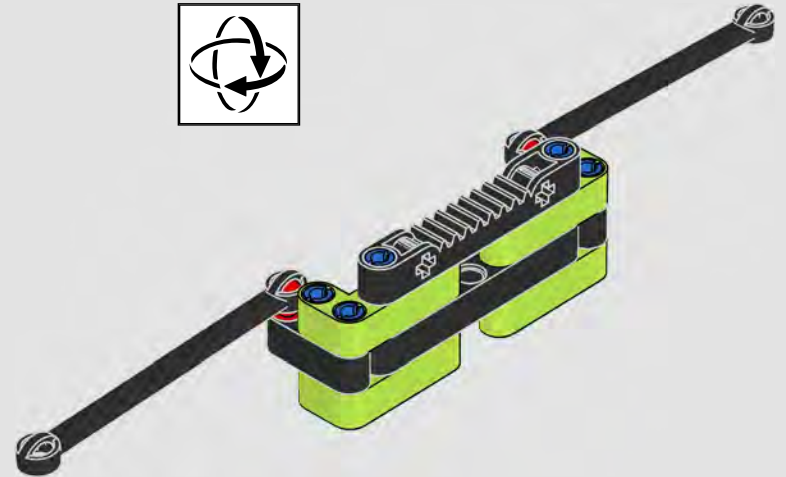

261

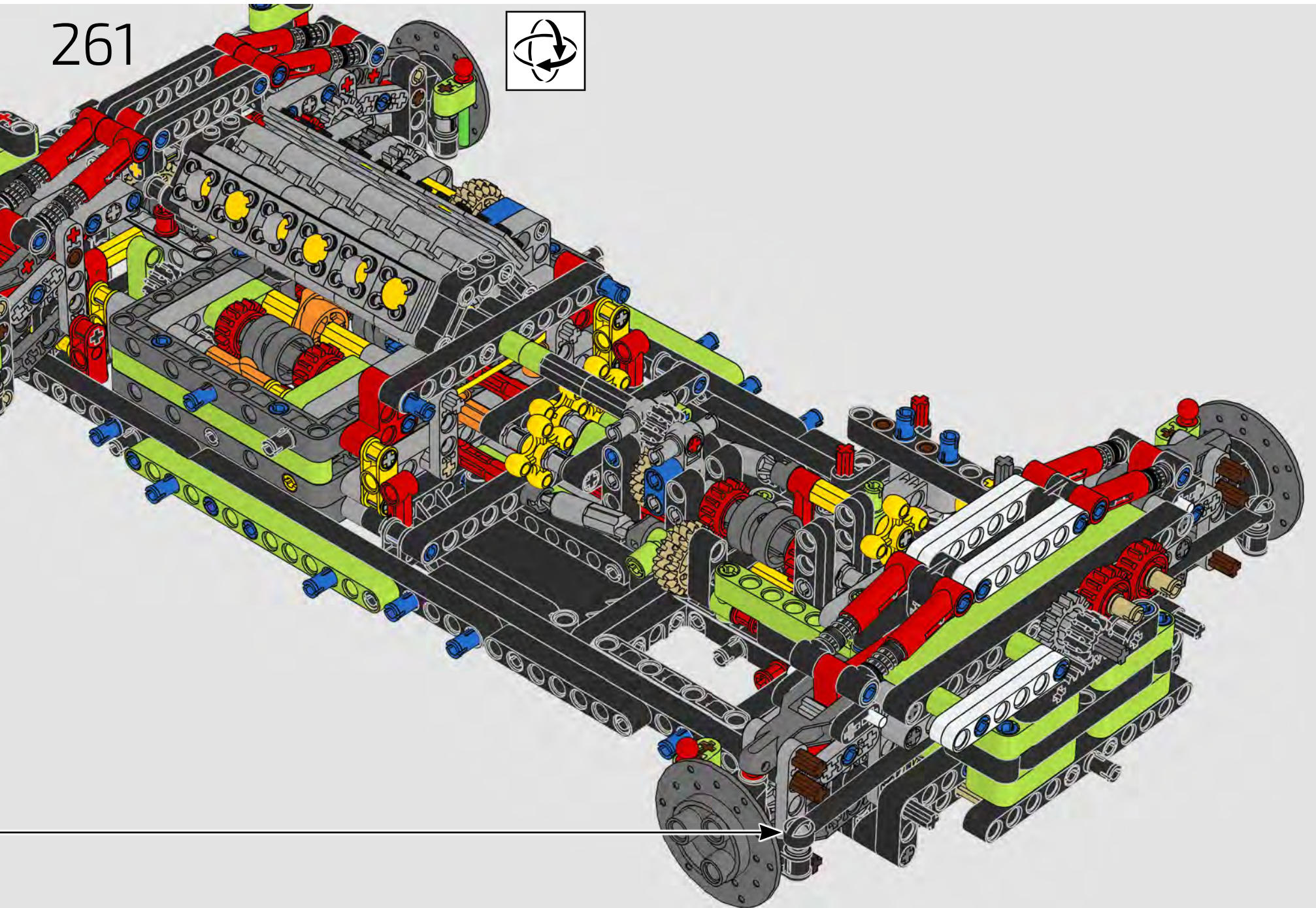

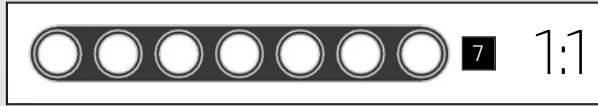
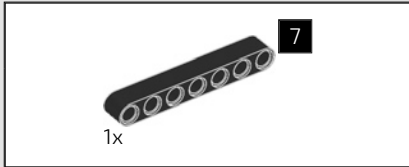

262

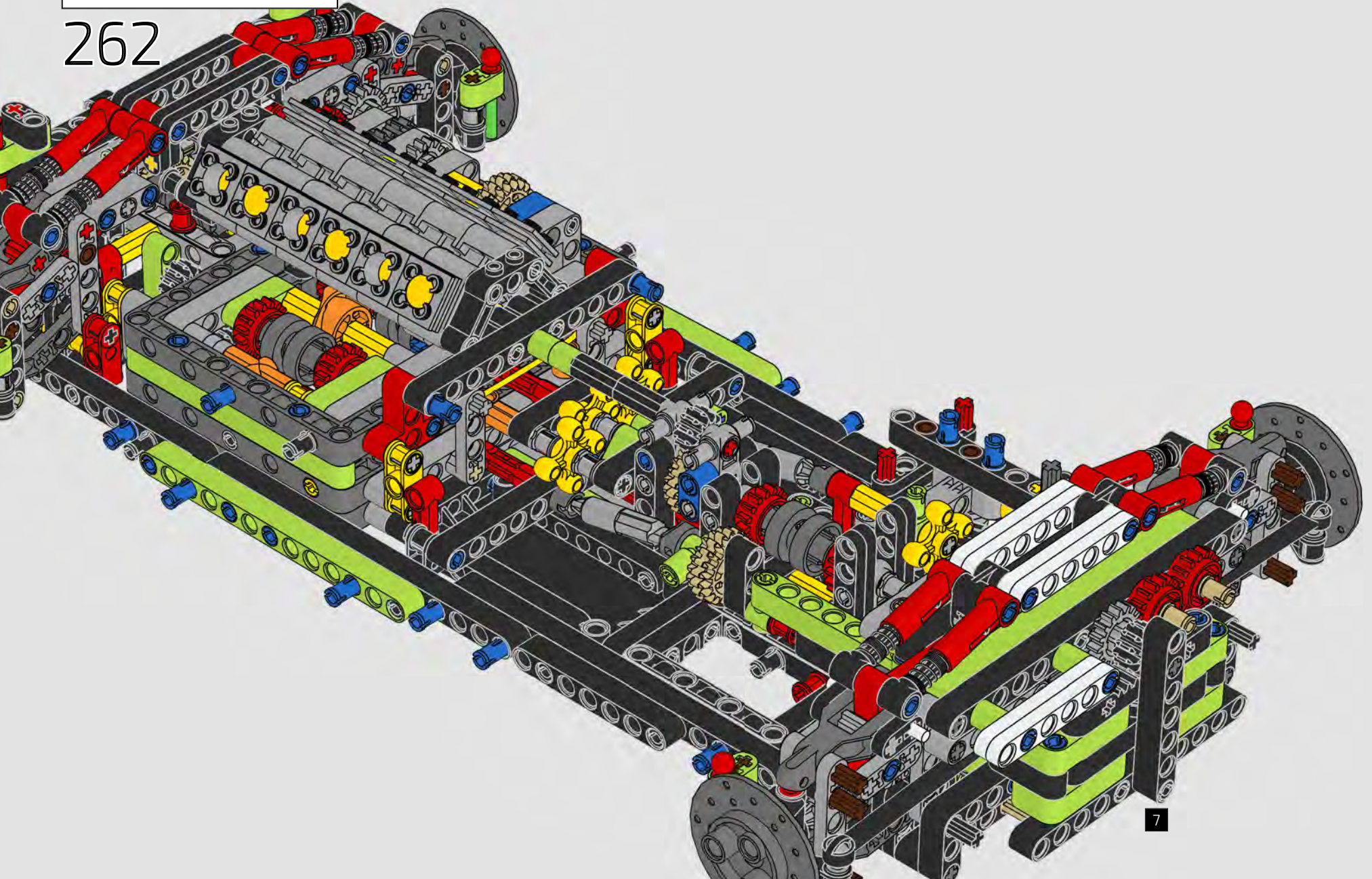

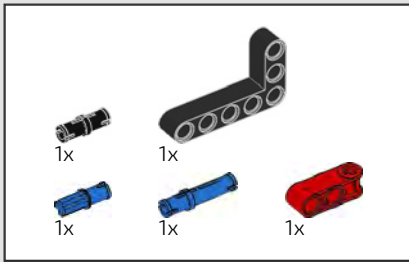

263

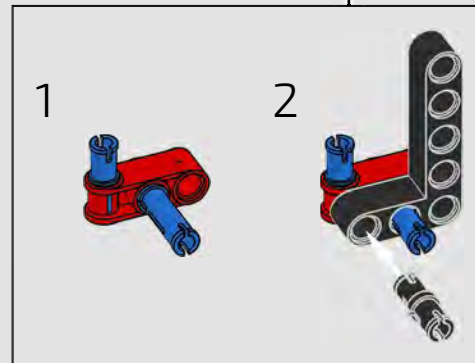
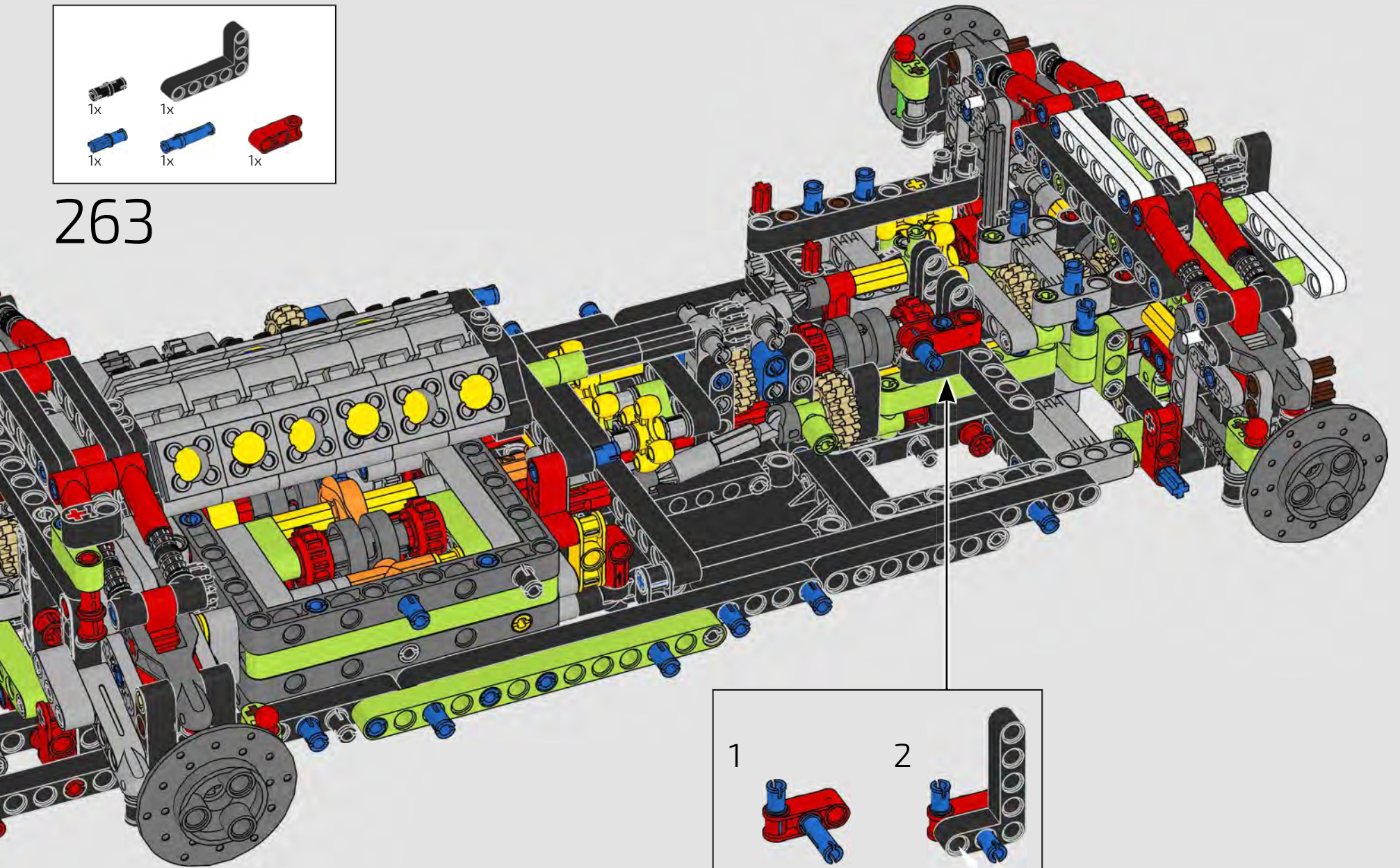

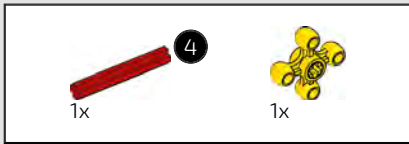

264

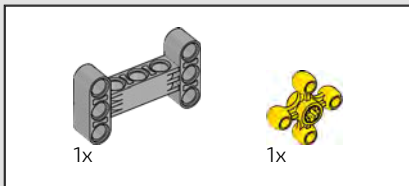
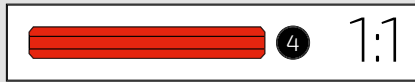
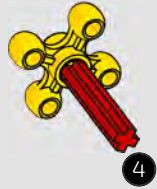

265

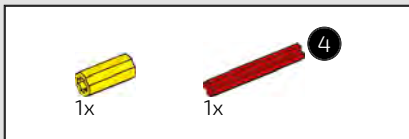
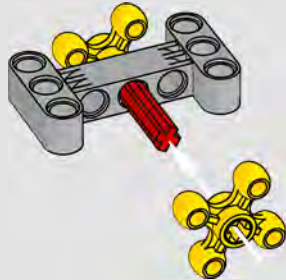

266

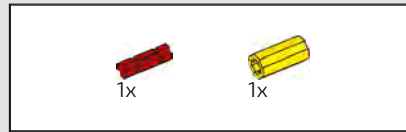
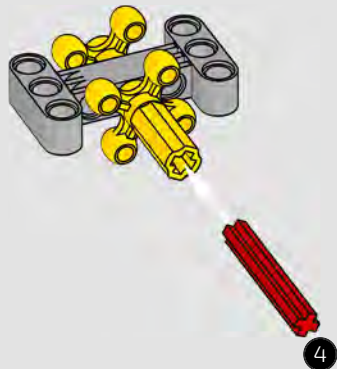

267

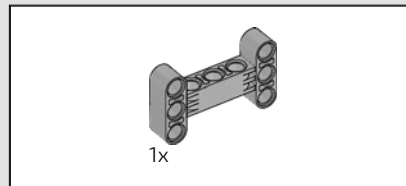
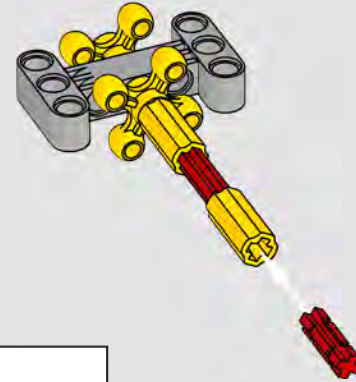

268

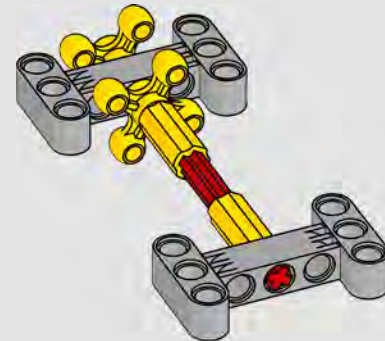

269

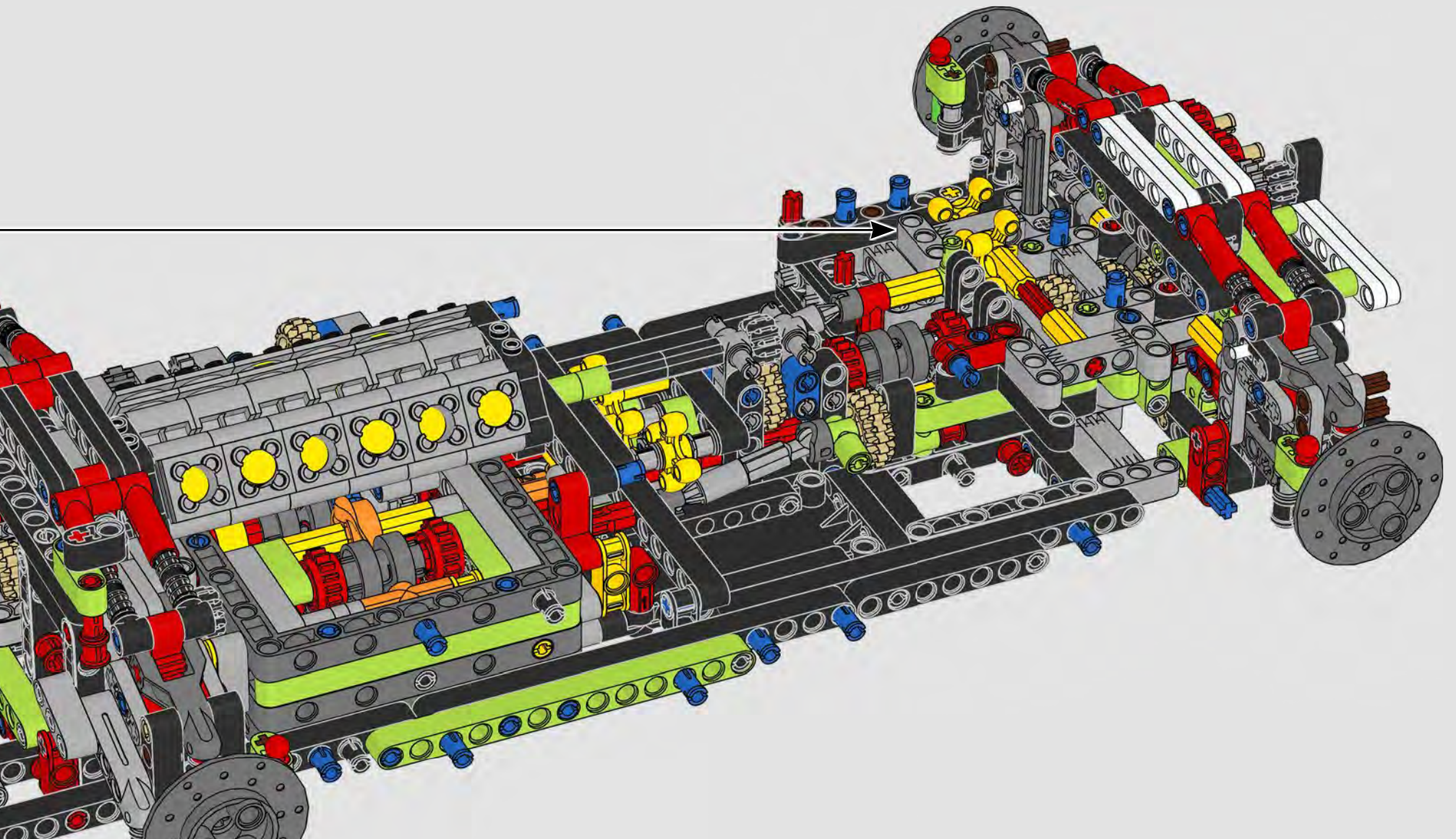

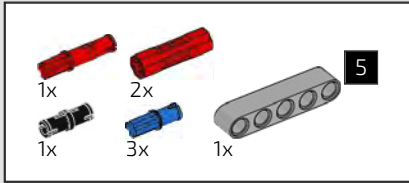

270

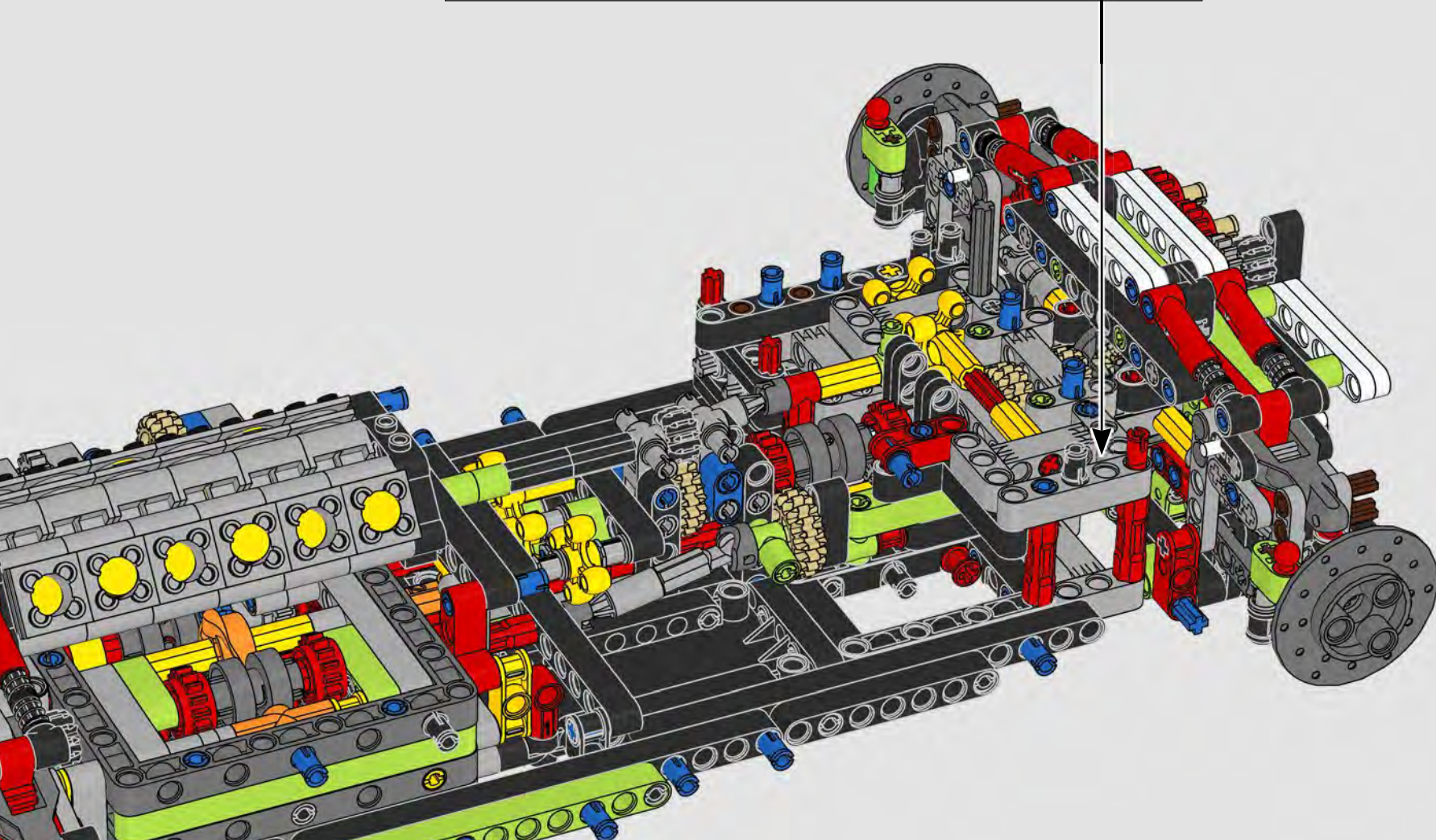
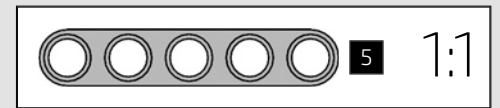
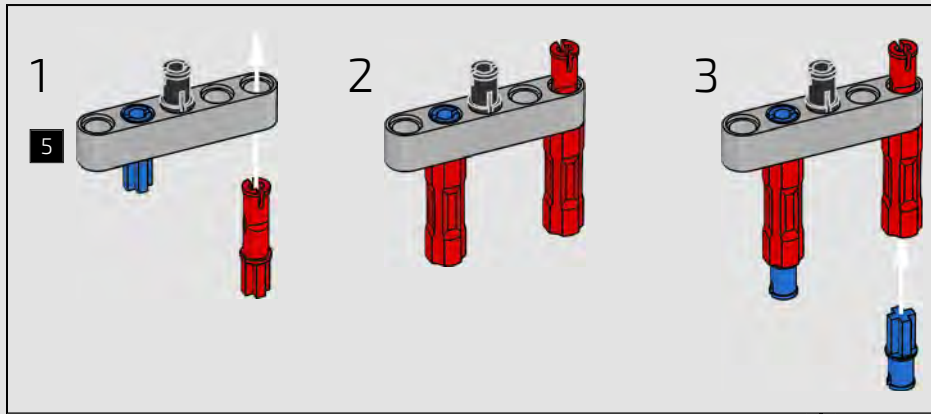

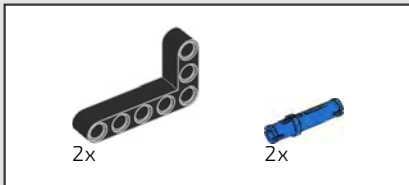

271

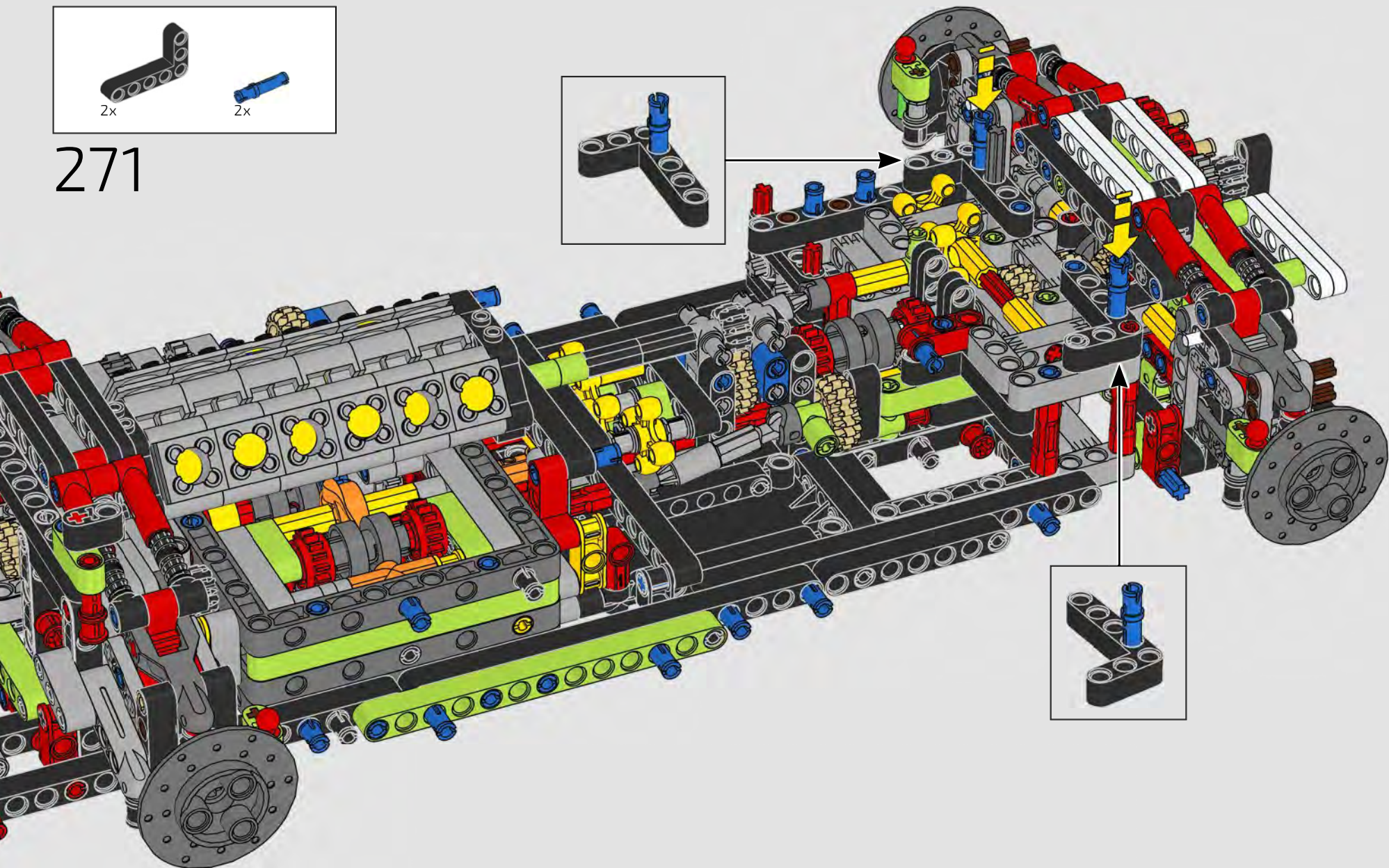

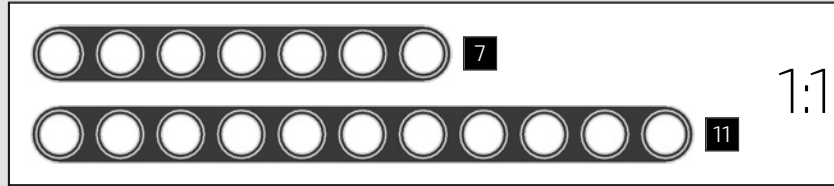
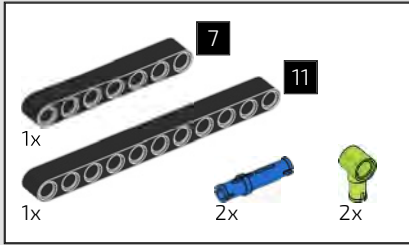

272

1



2



3

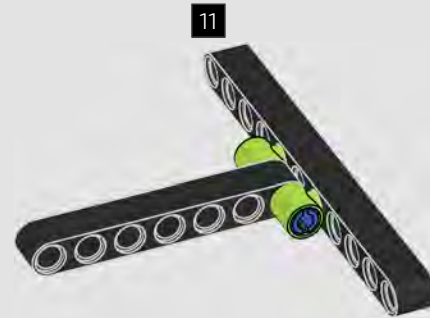

4

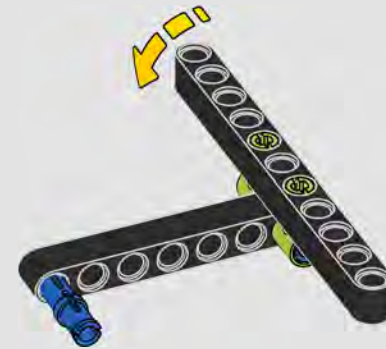

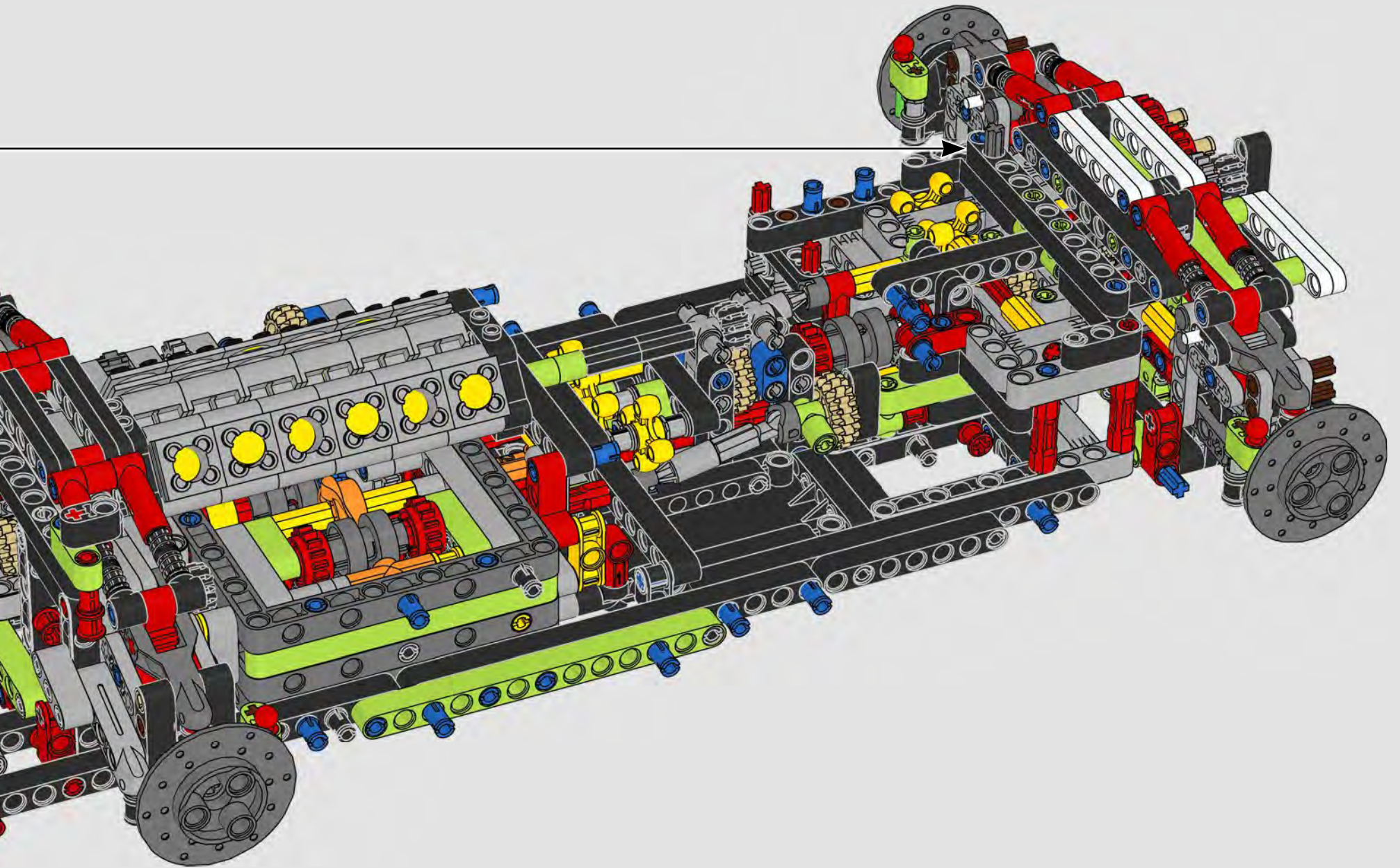

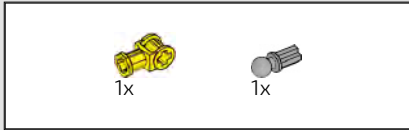

273

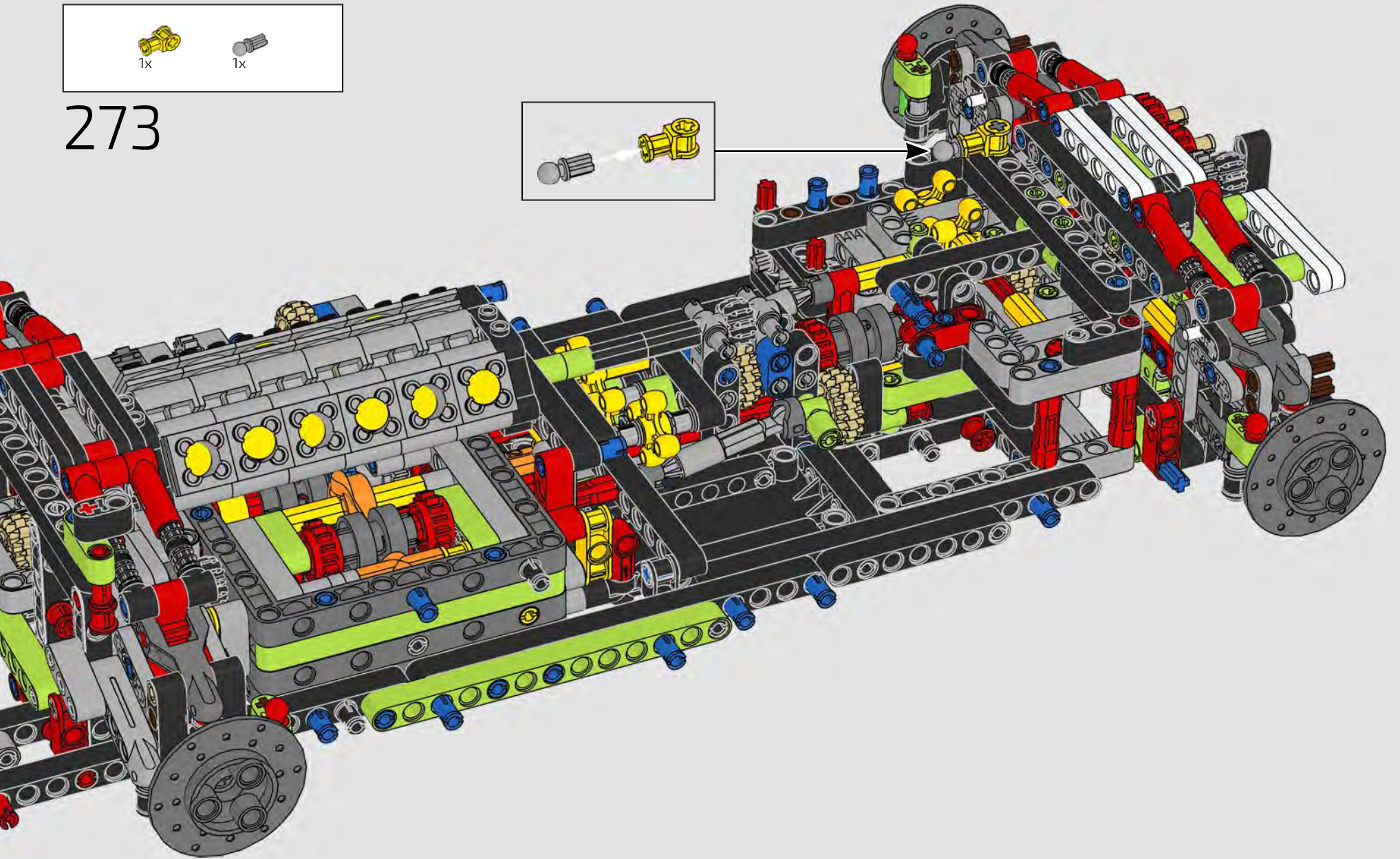
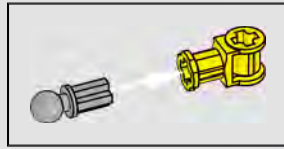

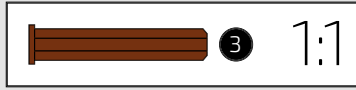
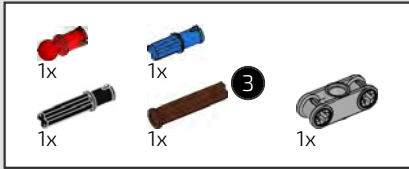

274

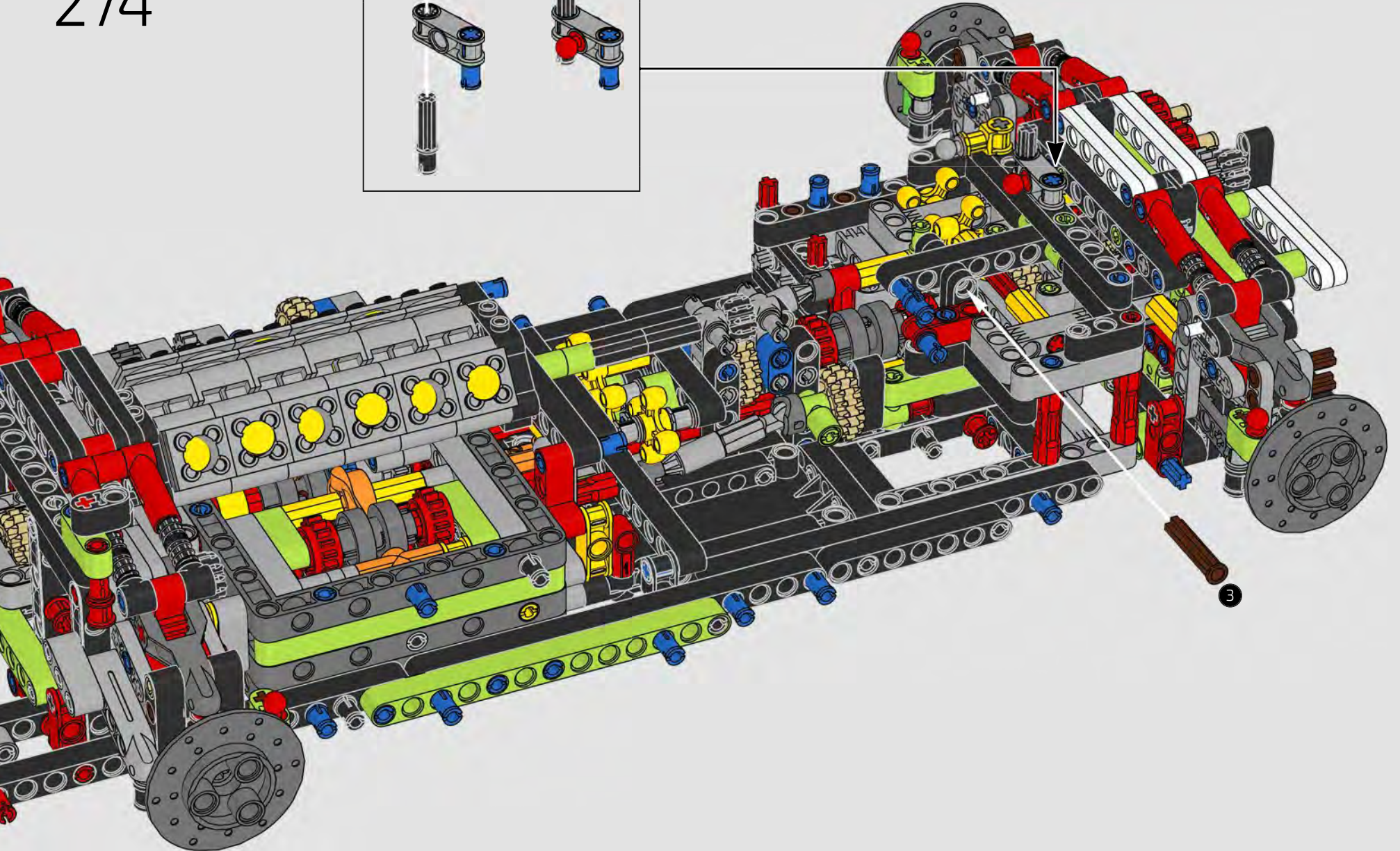
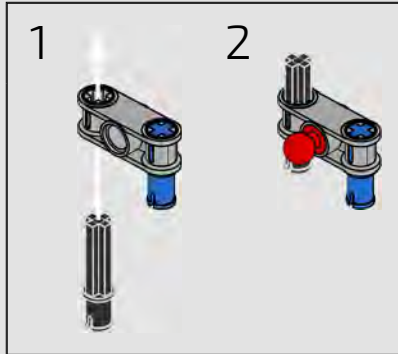

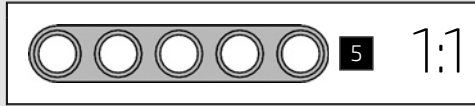
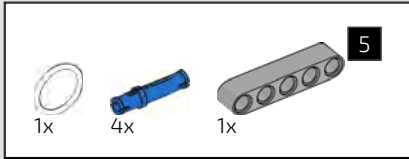

275

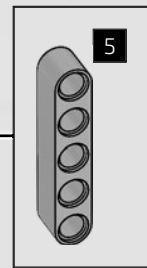
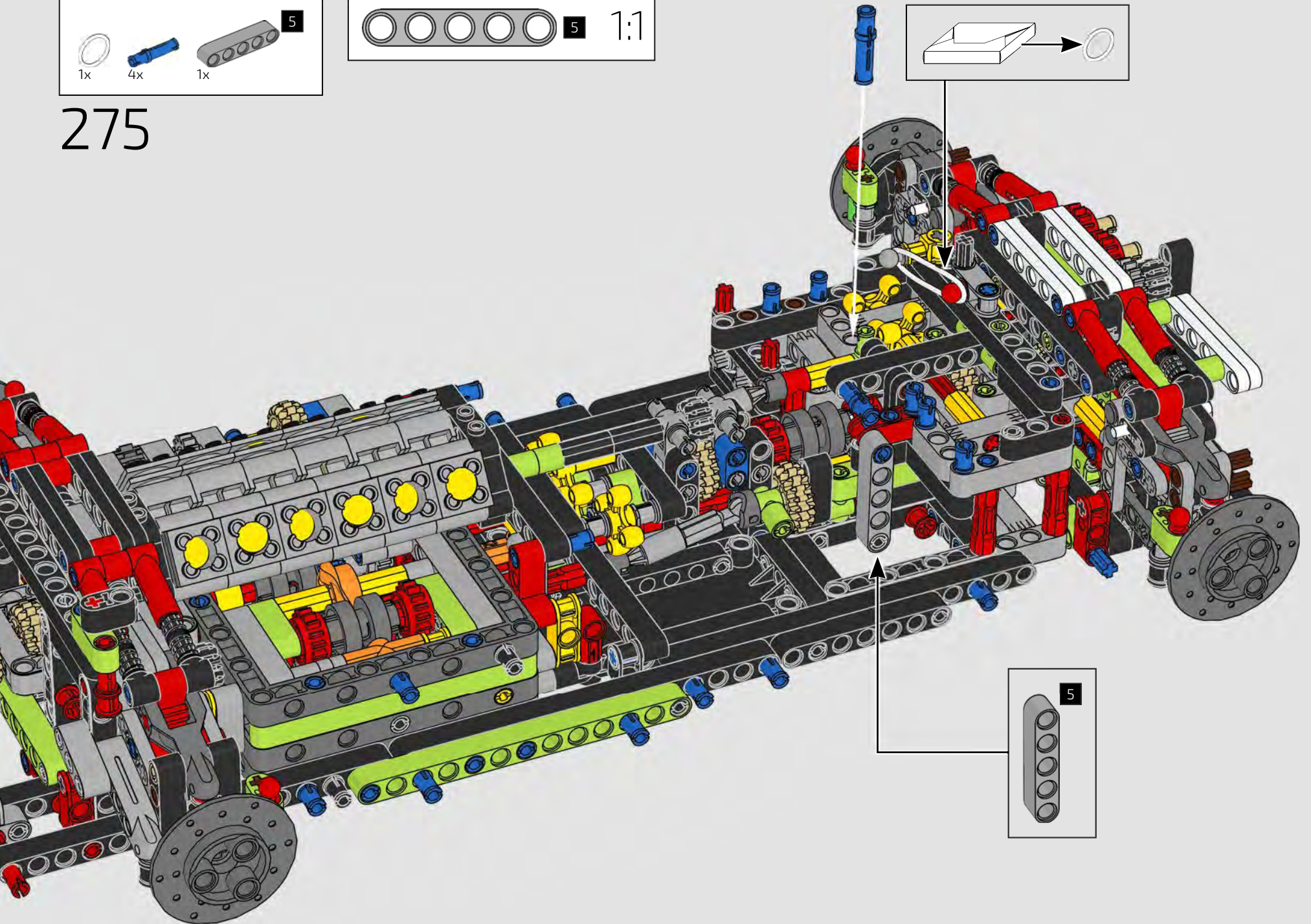

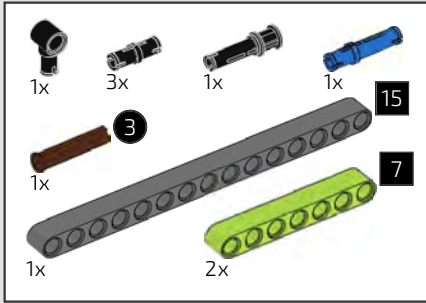

276

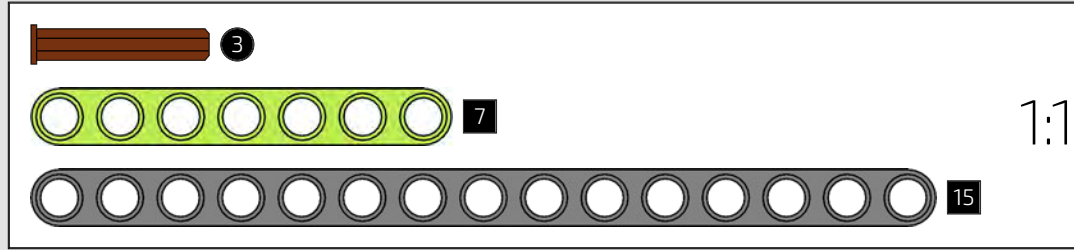

1



2

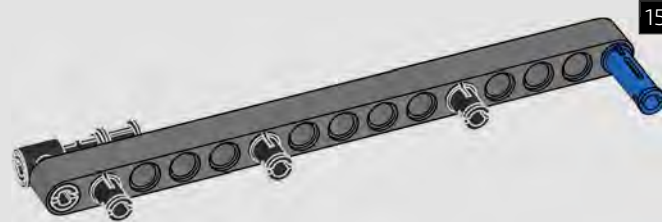

3

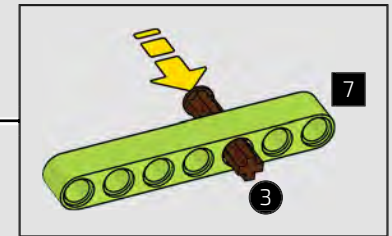
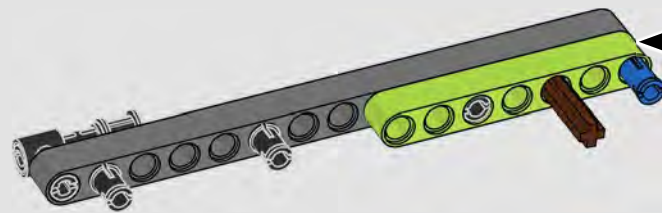

4

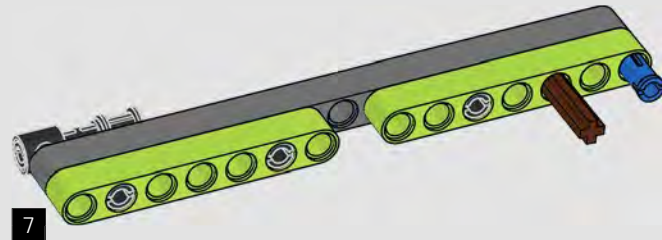

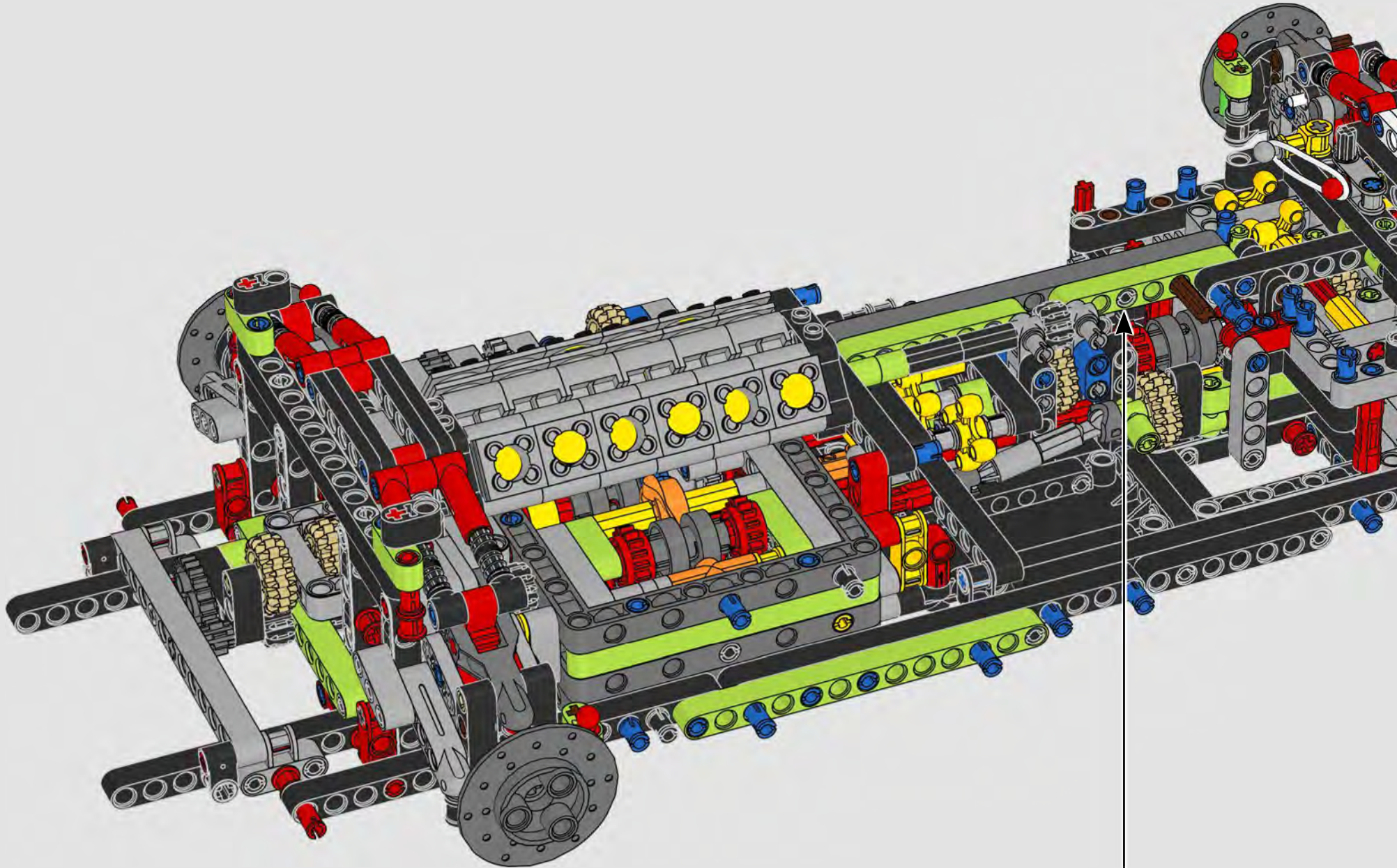



277

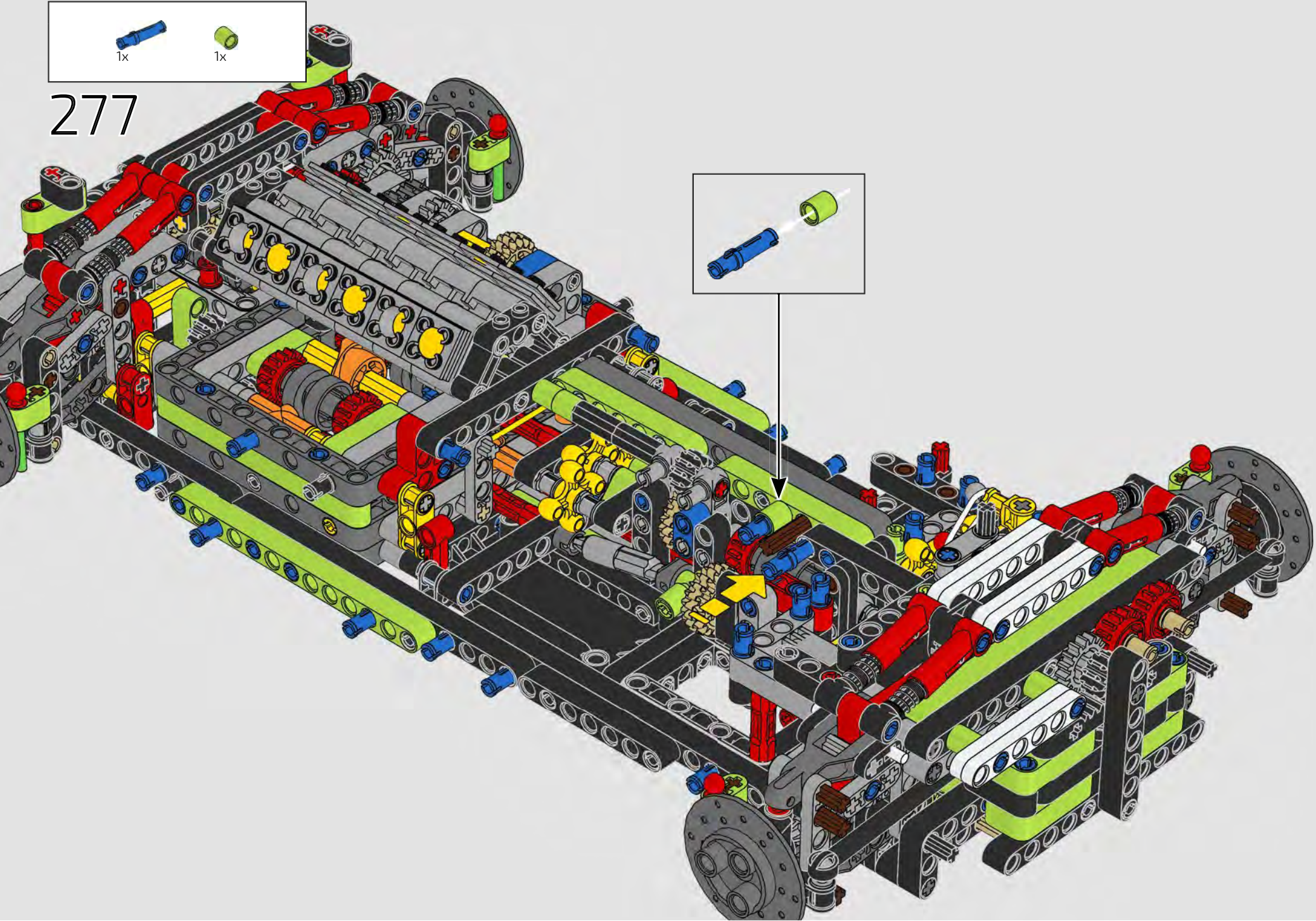

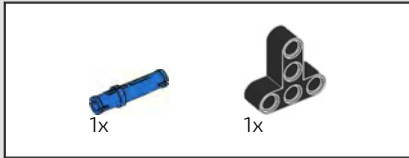

278

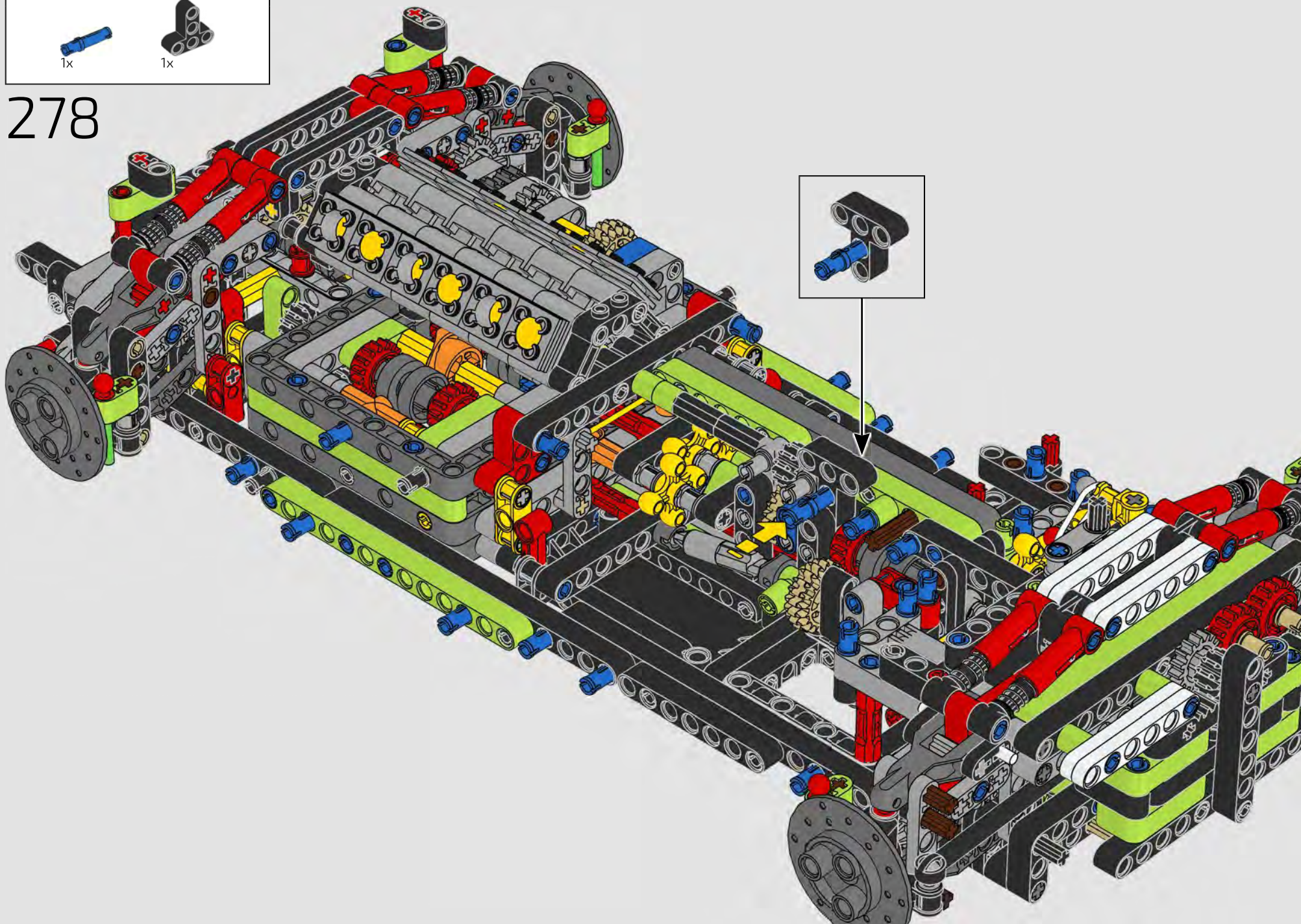



279

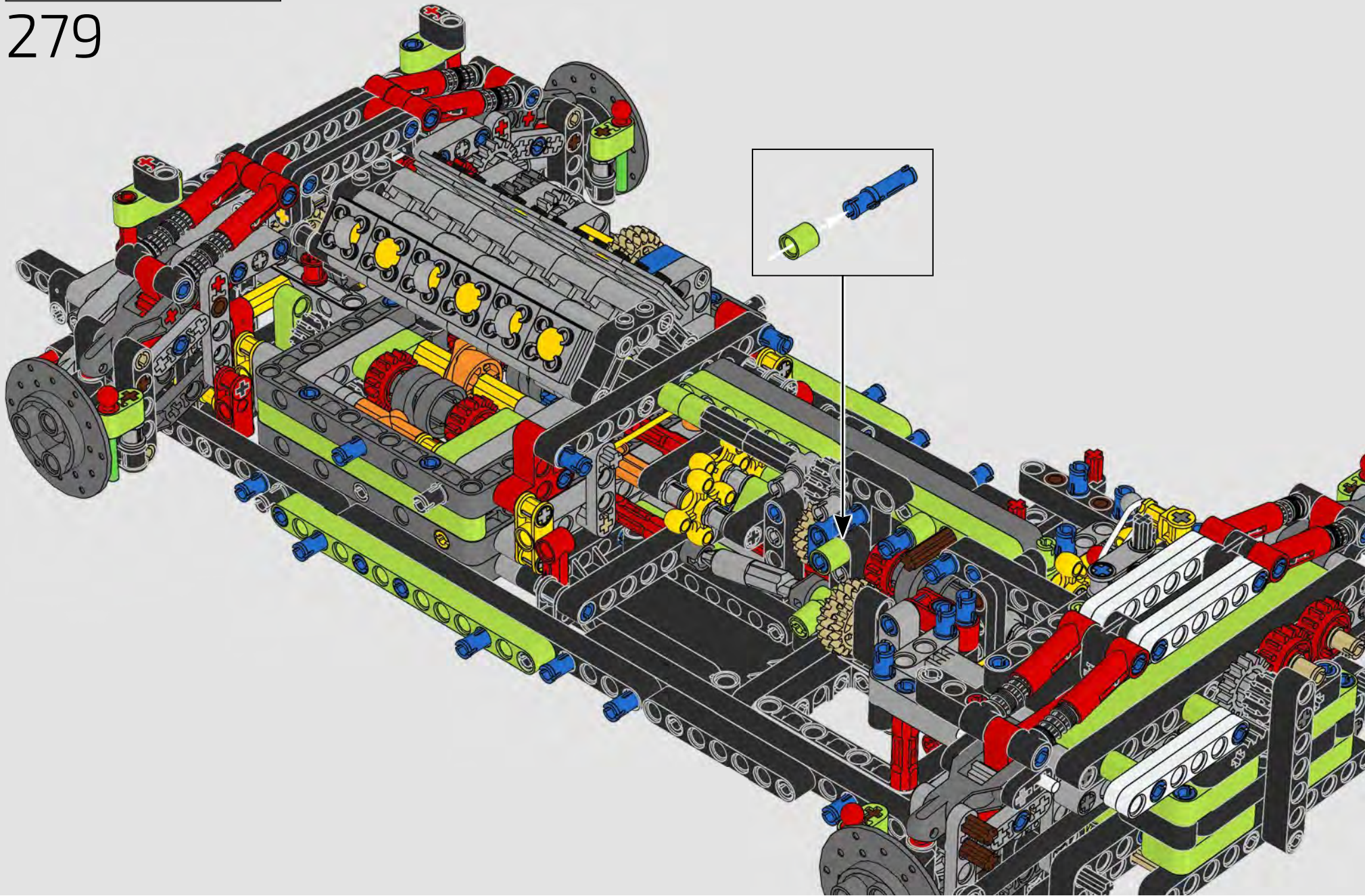

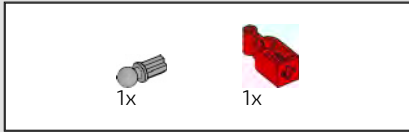

280

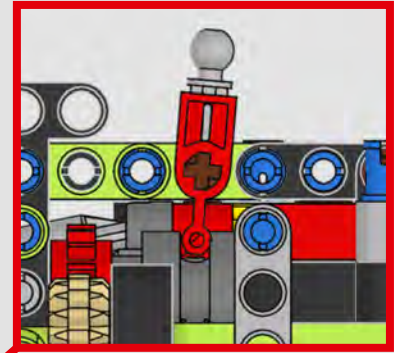
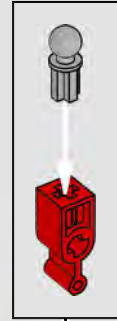
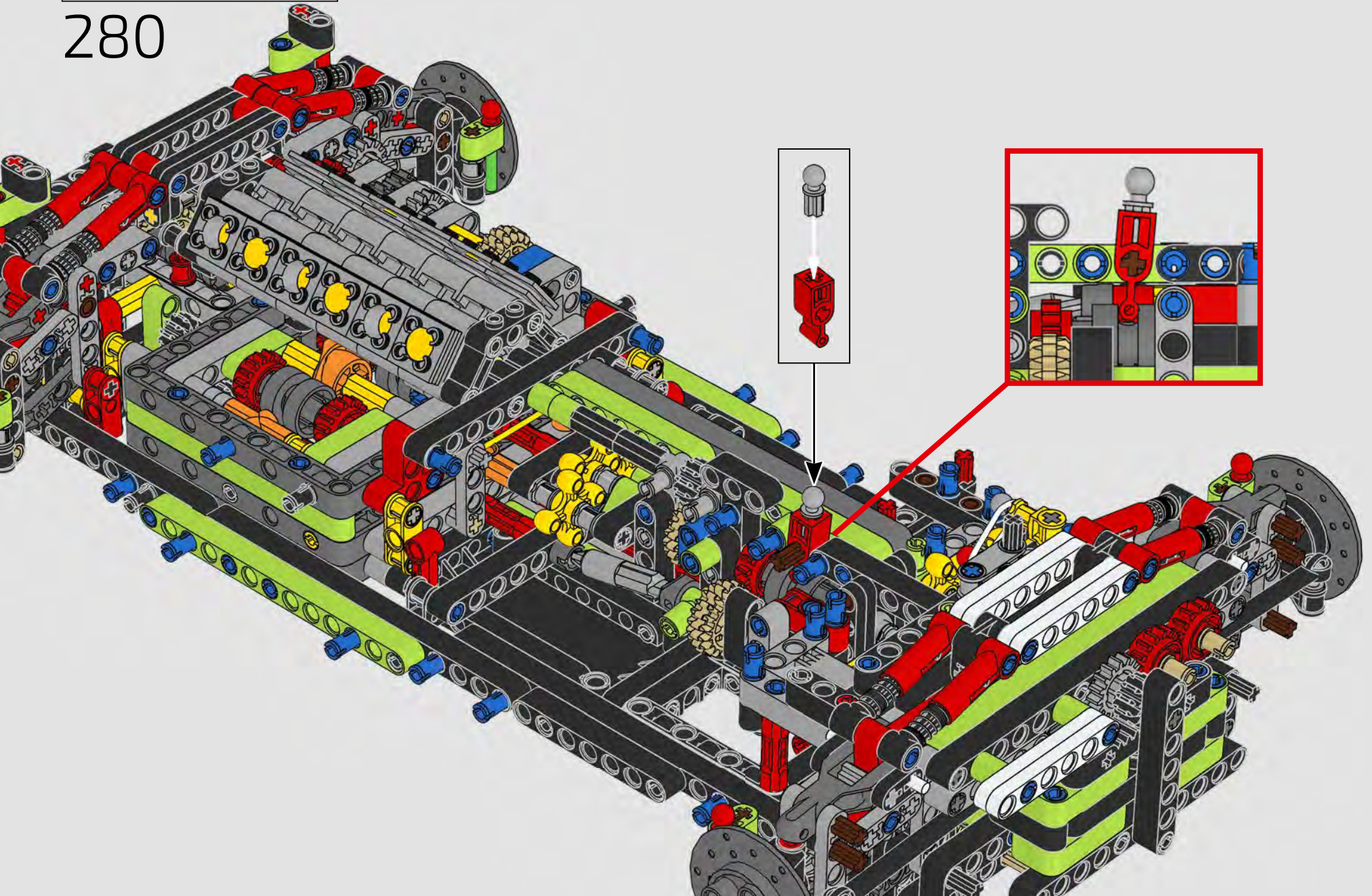

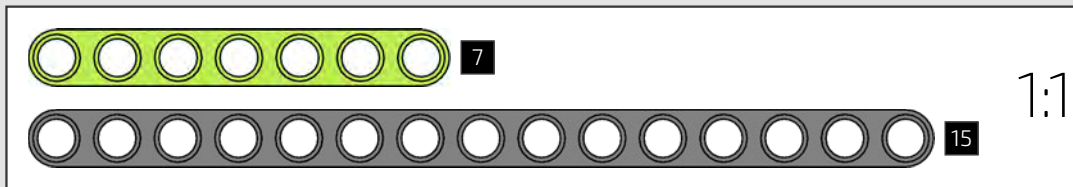
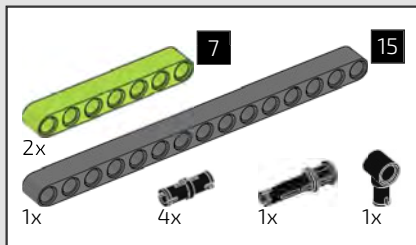

281

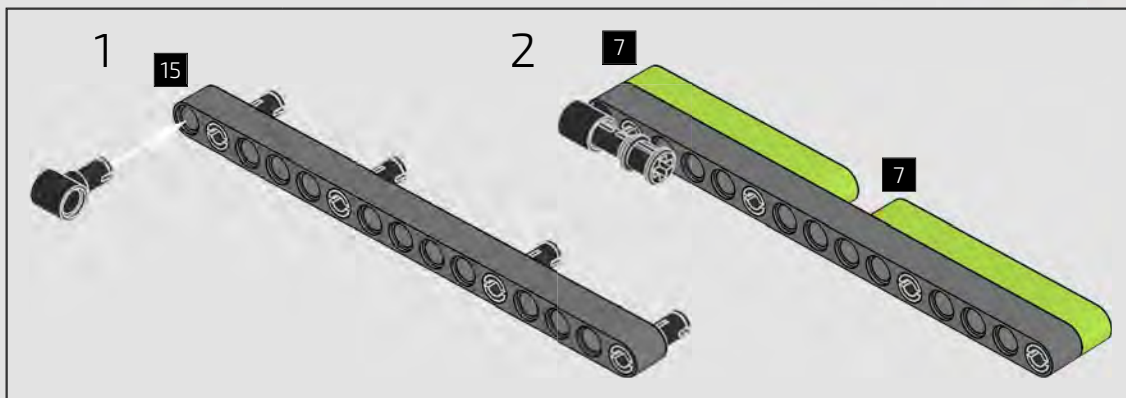
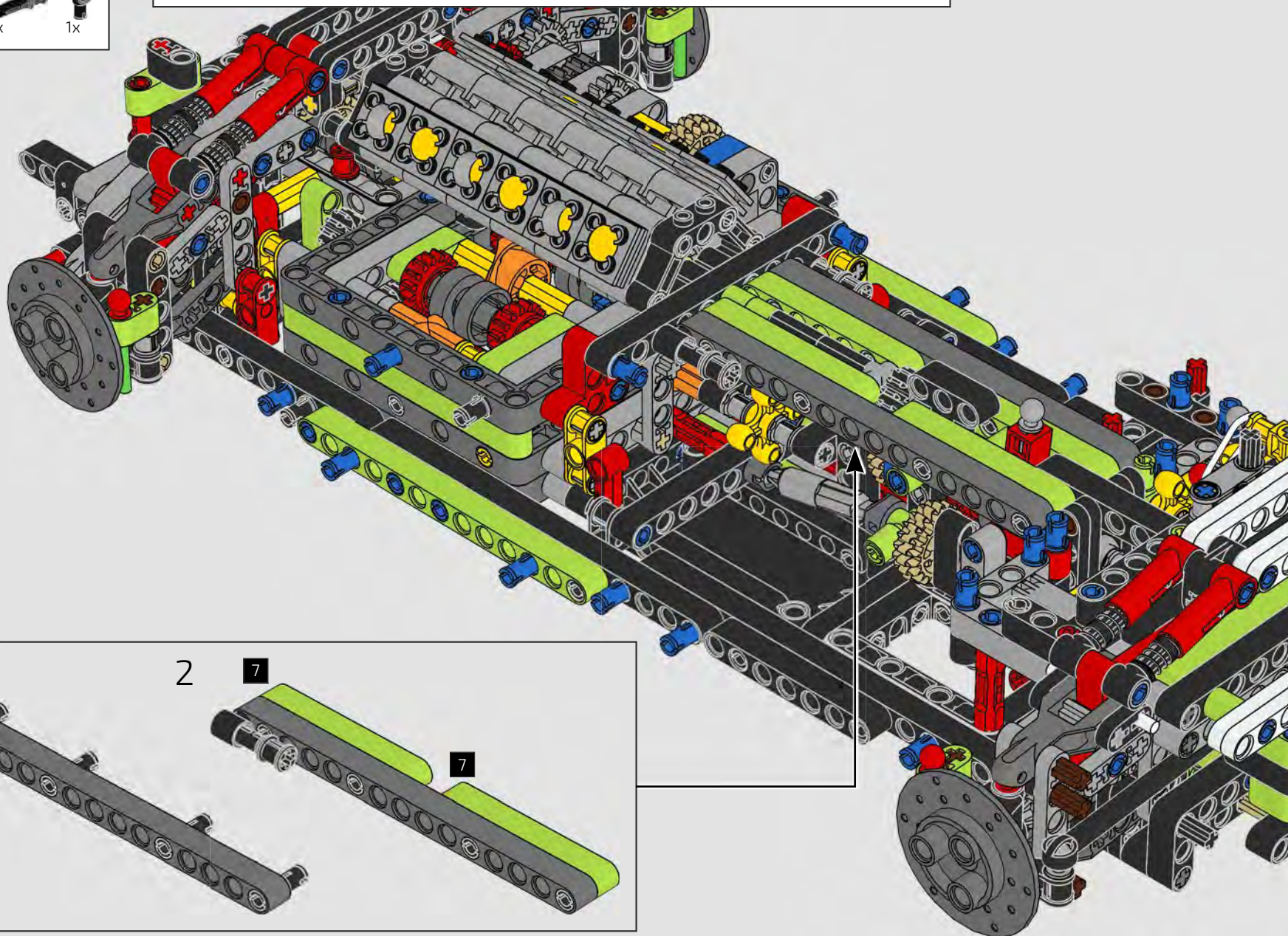



282

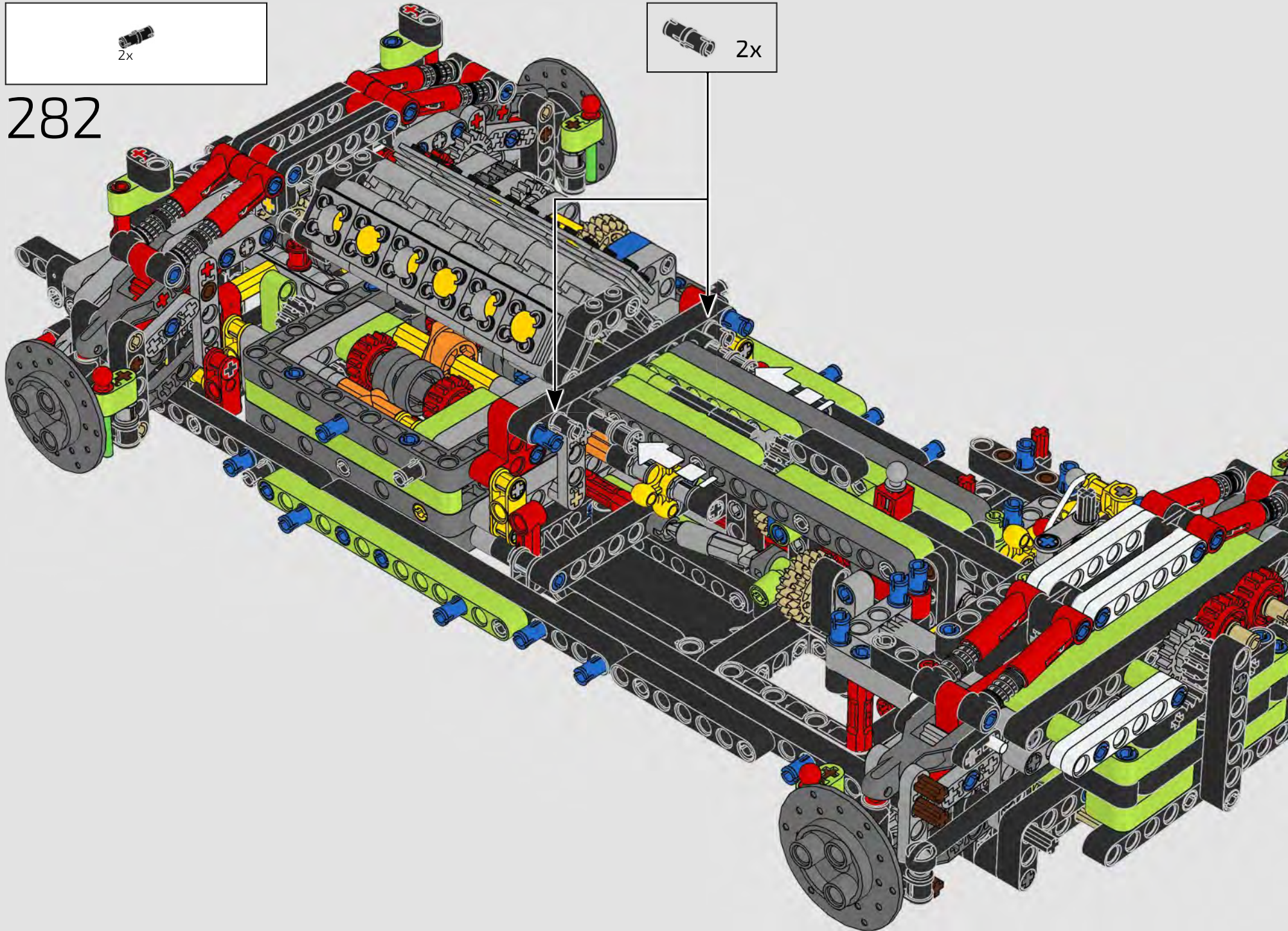

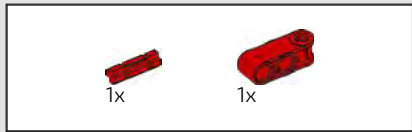

283

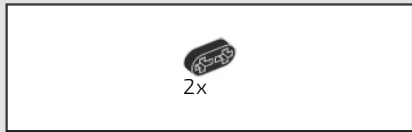
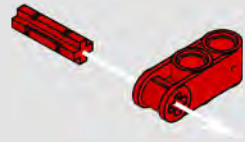

284

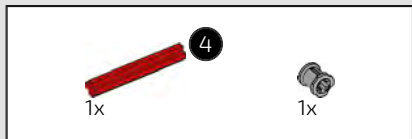

285

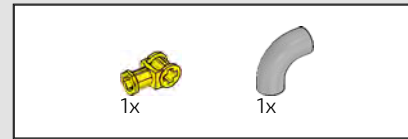
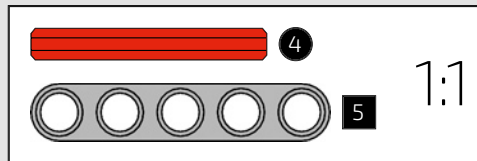
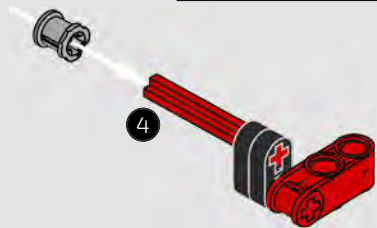

286

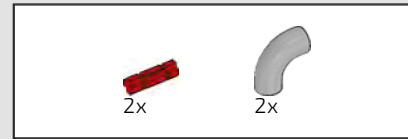
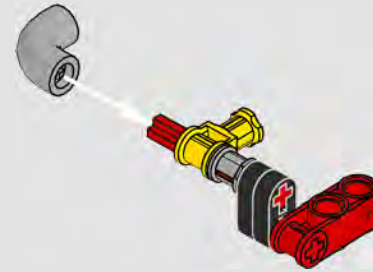

287

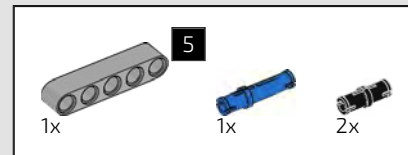
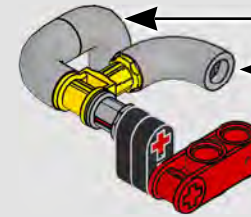
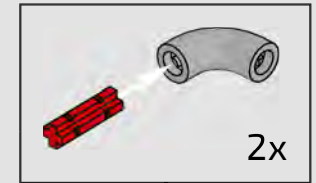

288

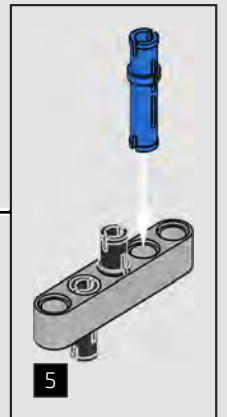
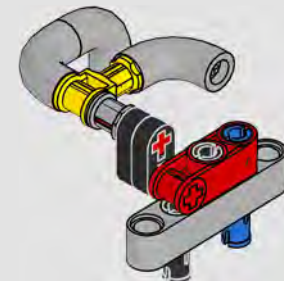

289

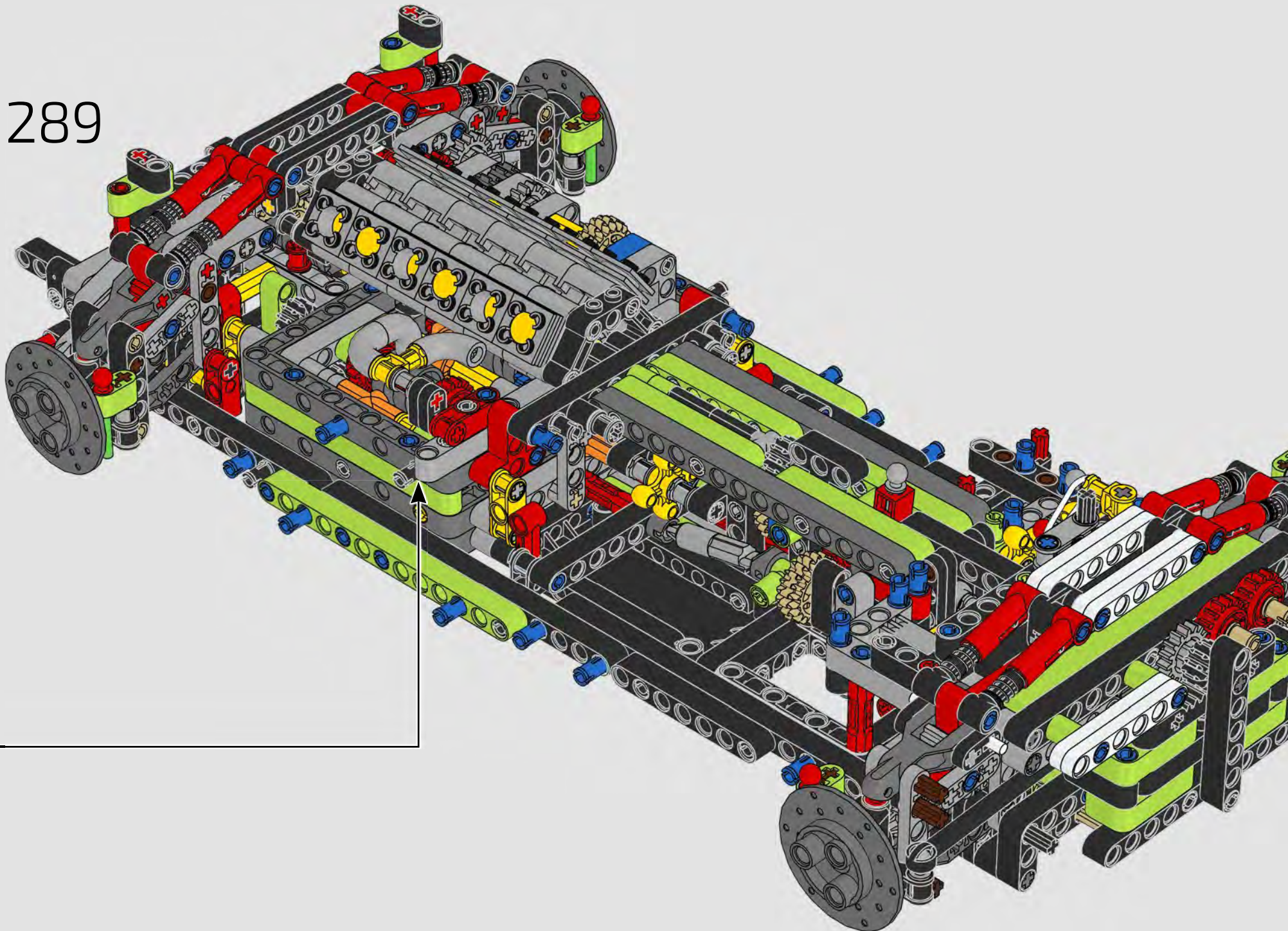

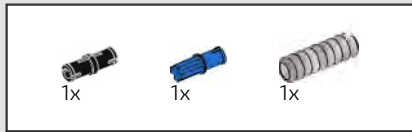

290

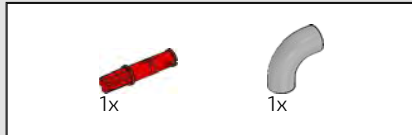
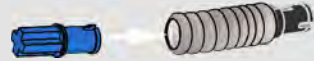

291

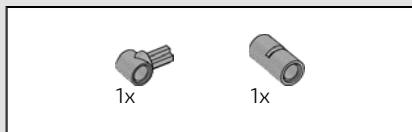
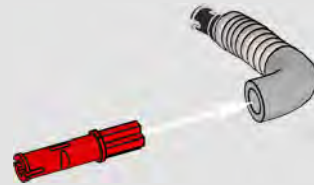

292

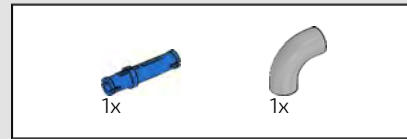
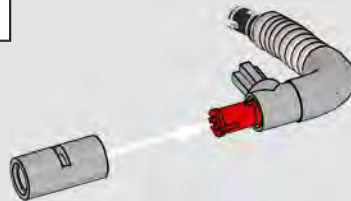

293

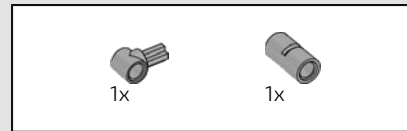
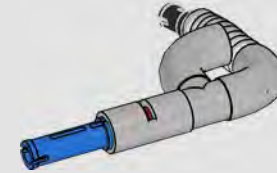

294

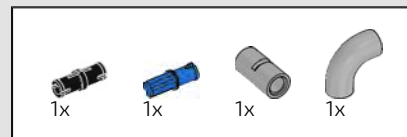
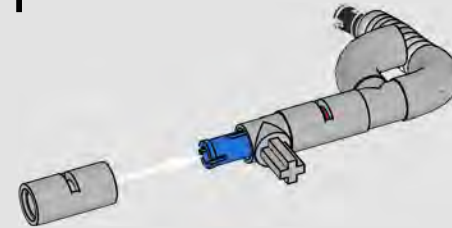

295

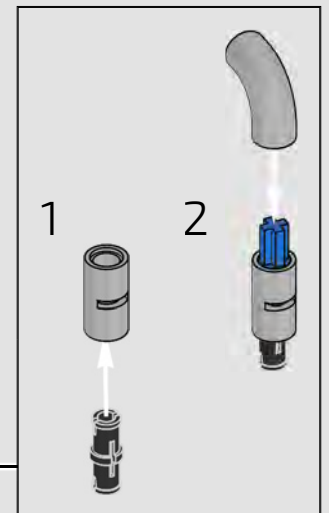
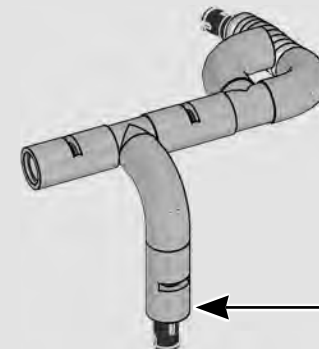

296

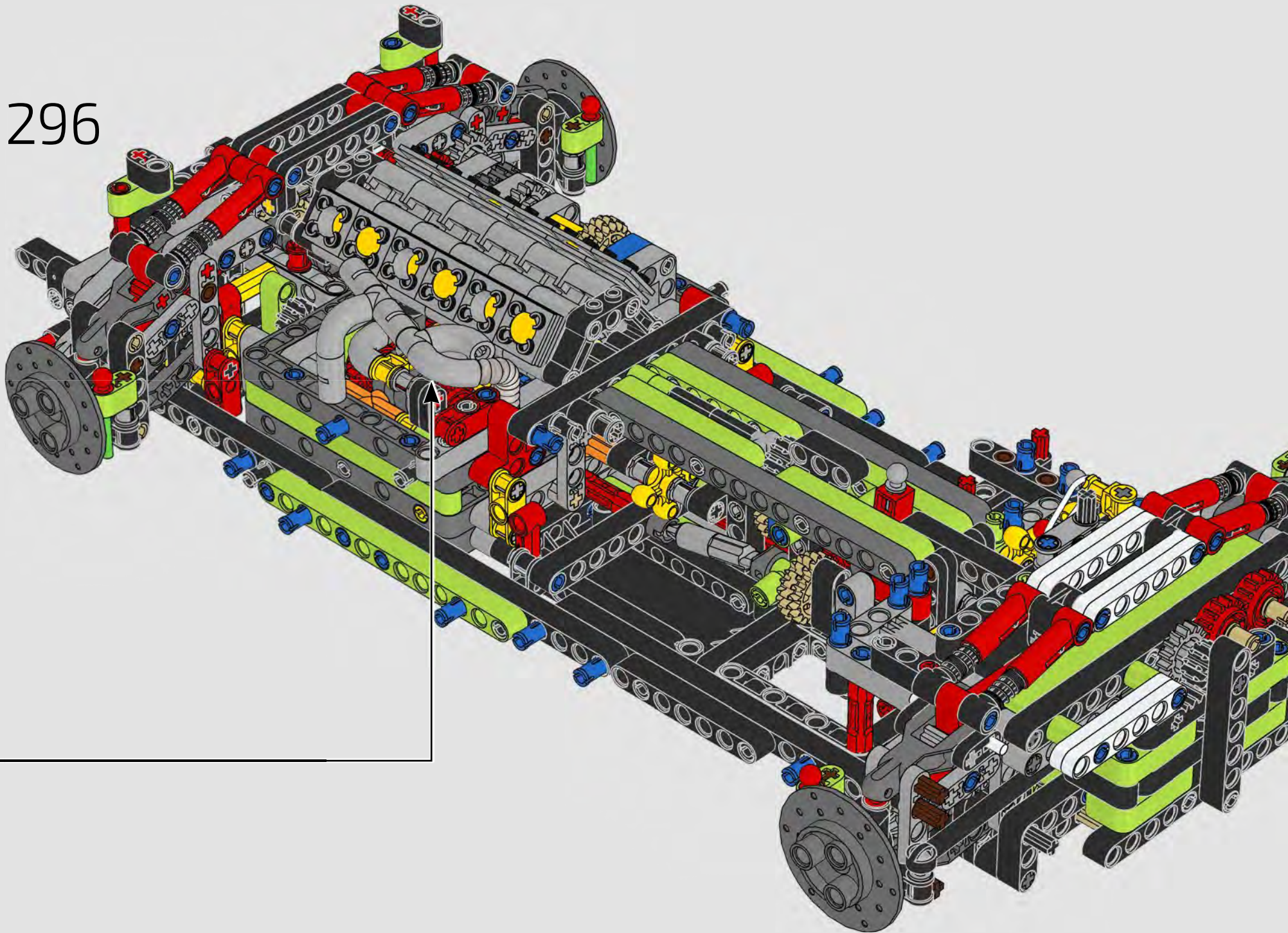

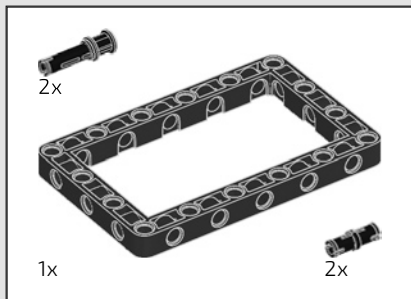

297

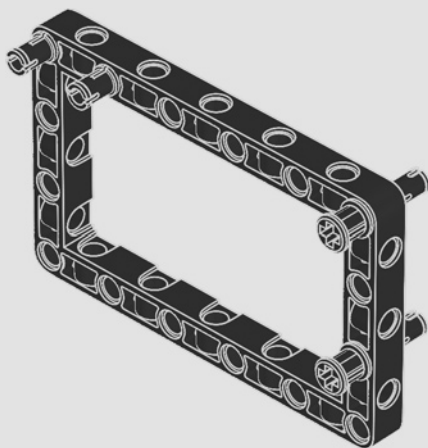

298

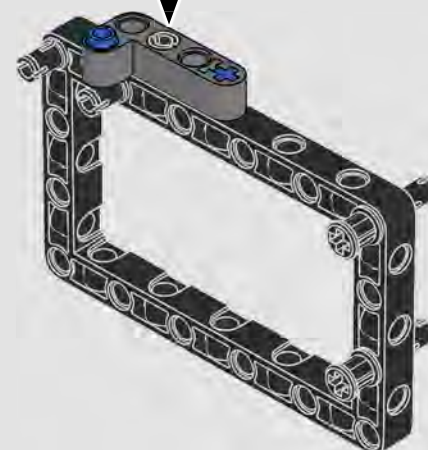
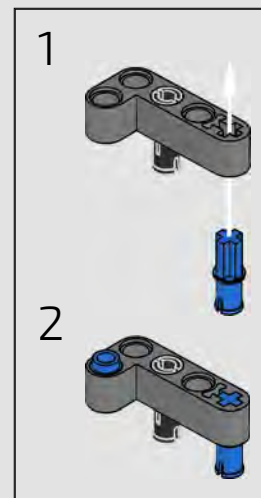

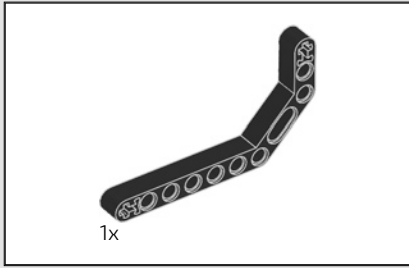

299

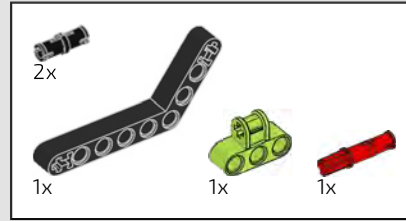
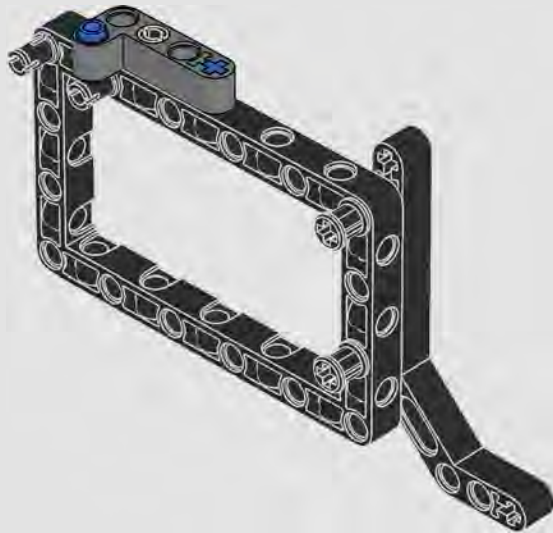

300

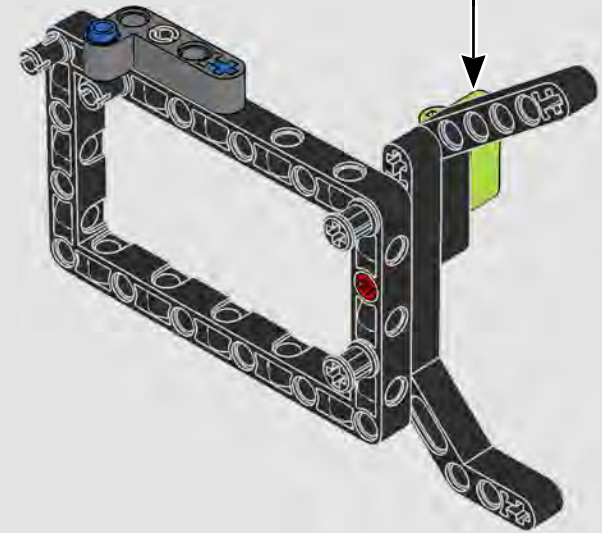
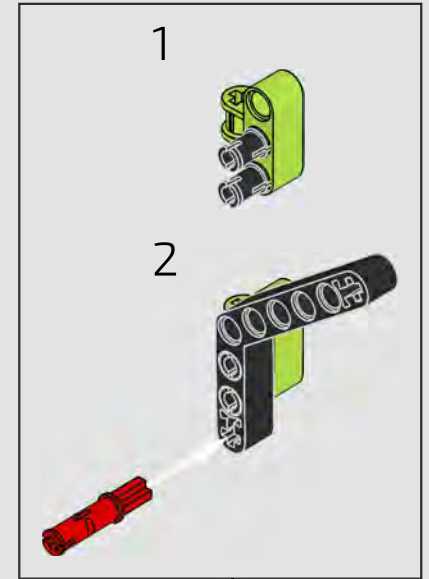

301

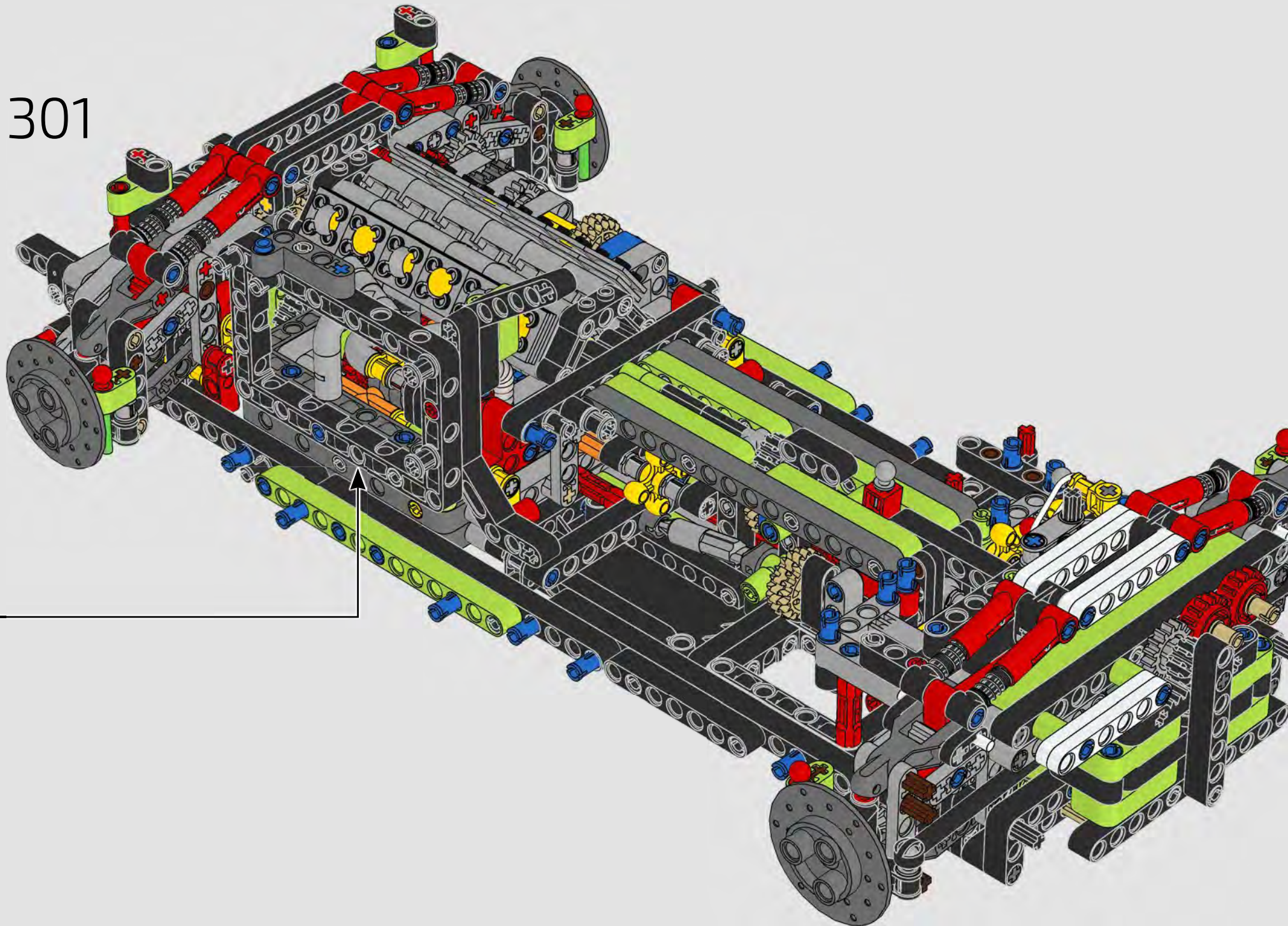

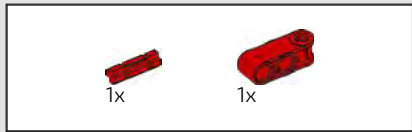

303

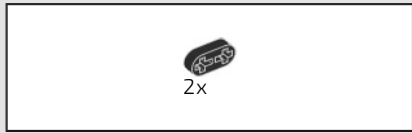
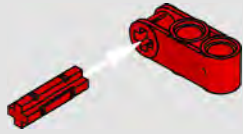

304

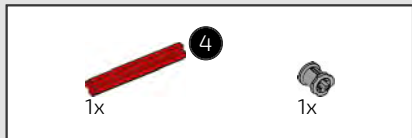

305

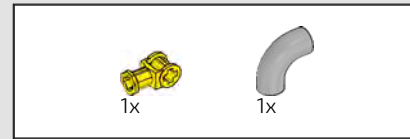
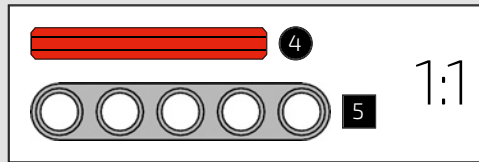

306

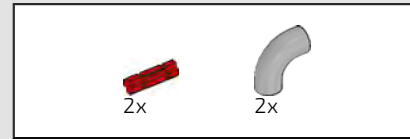
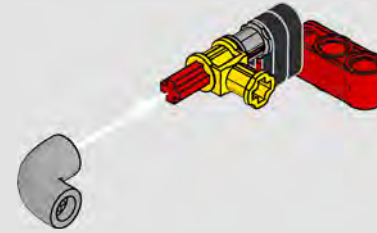

307

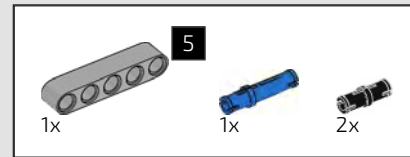
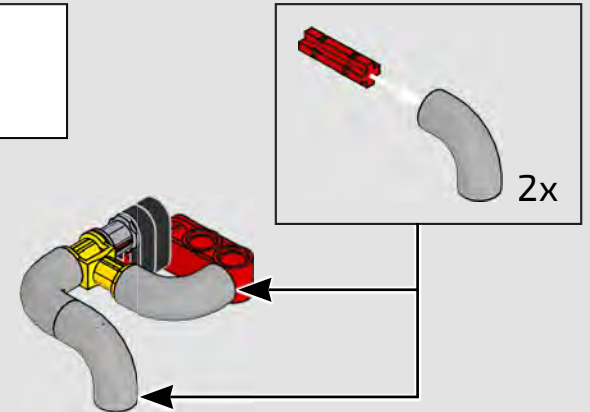

308

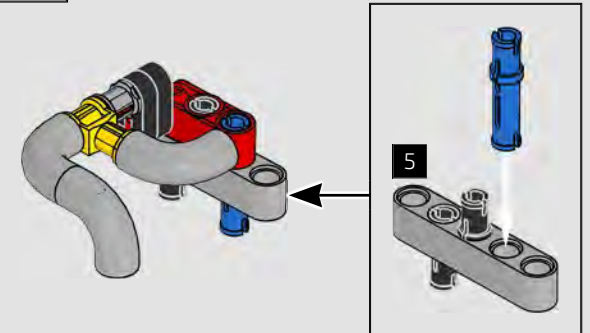



309

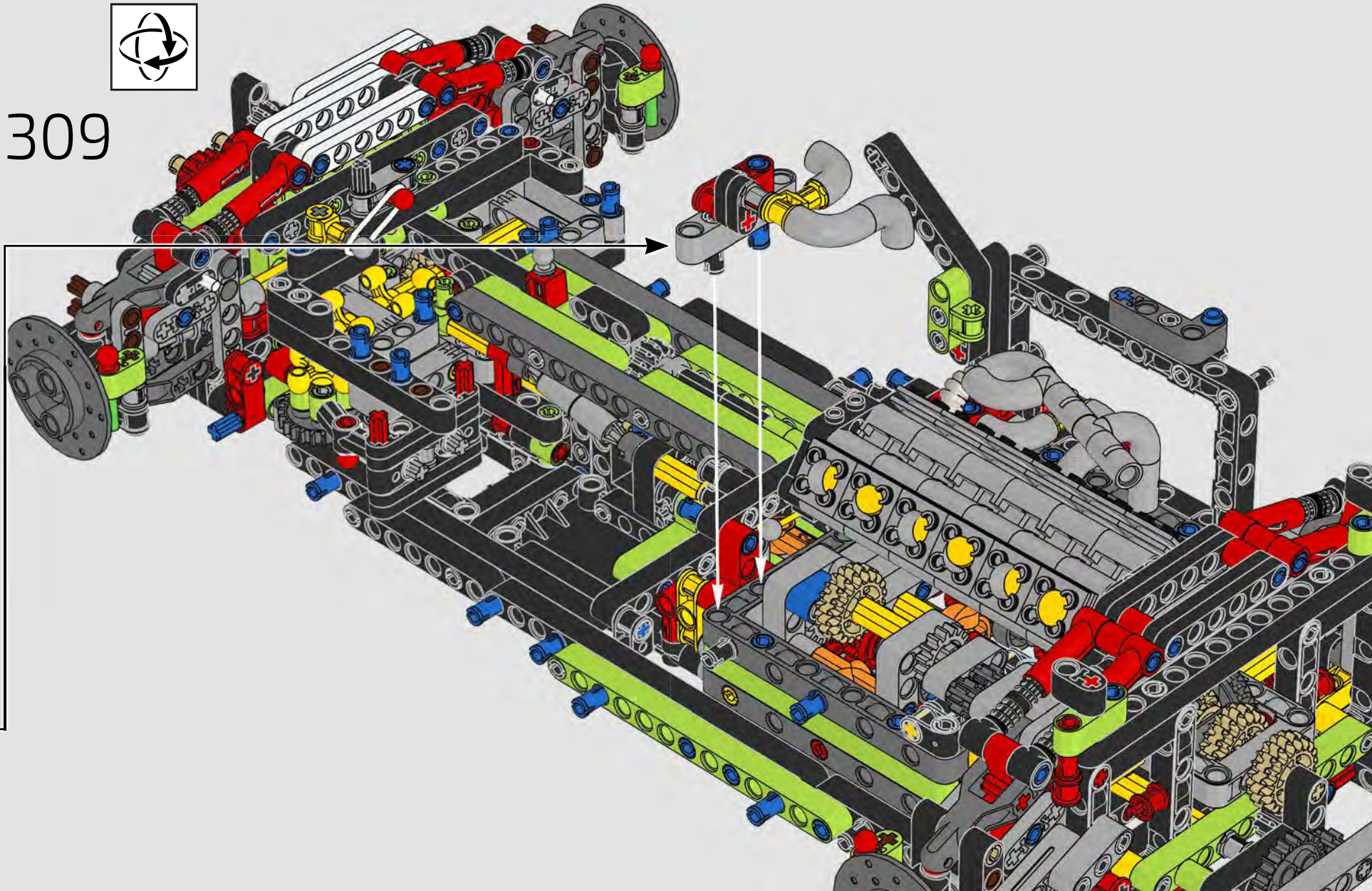

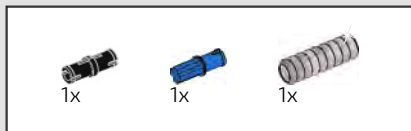

310



311

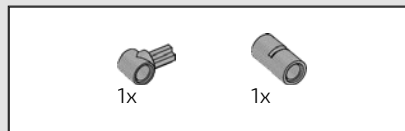

312

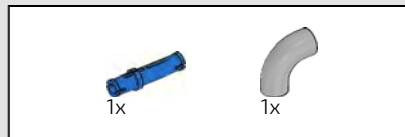

313



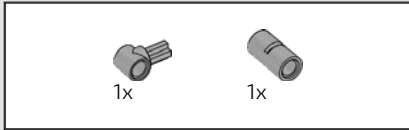

314

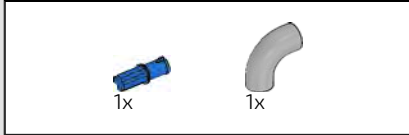
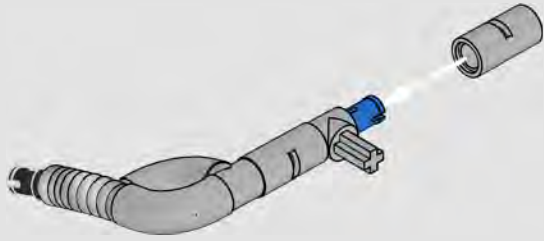

315

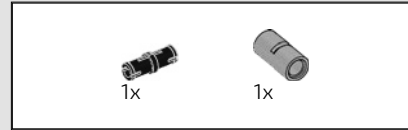
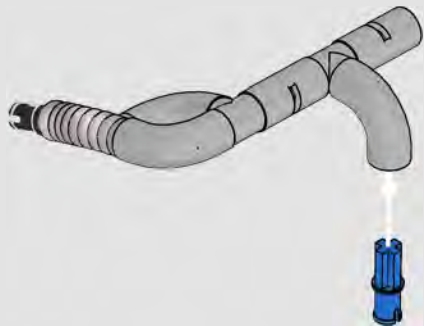

316

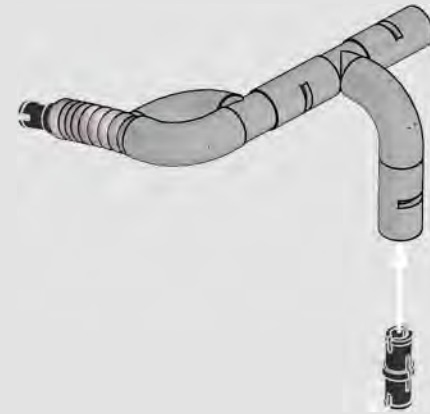

317

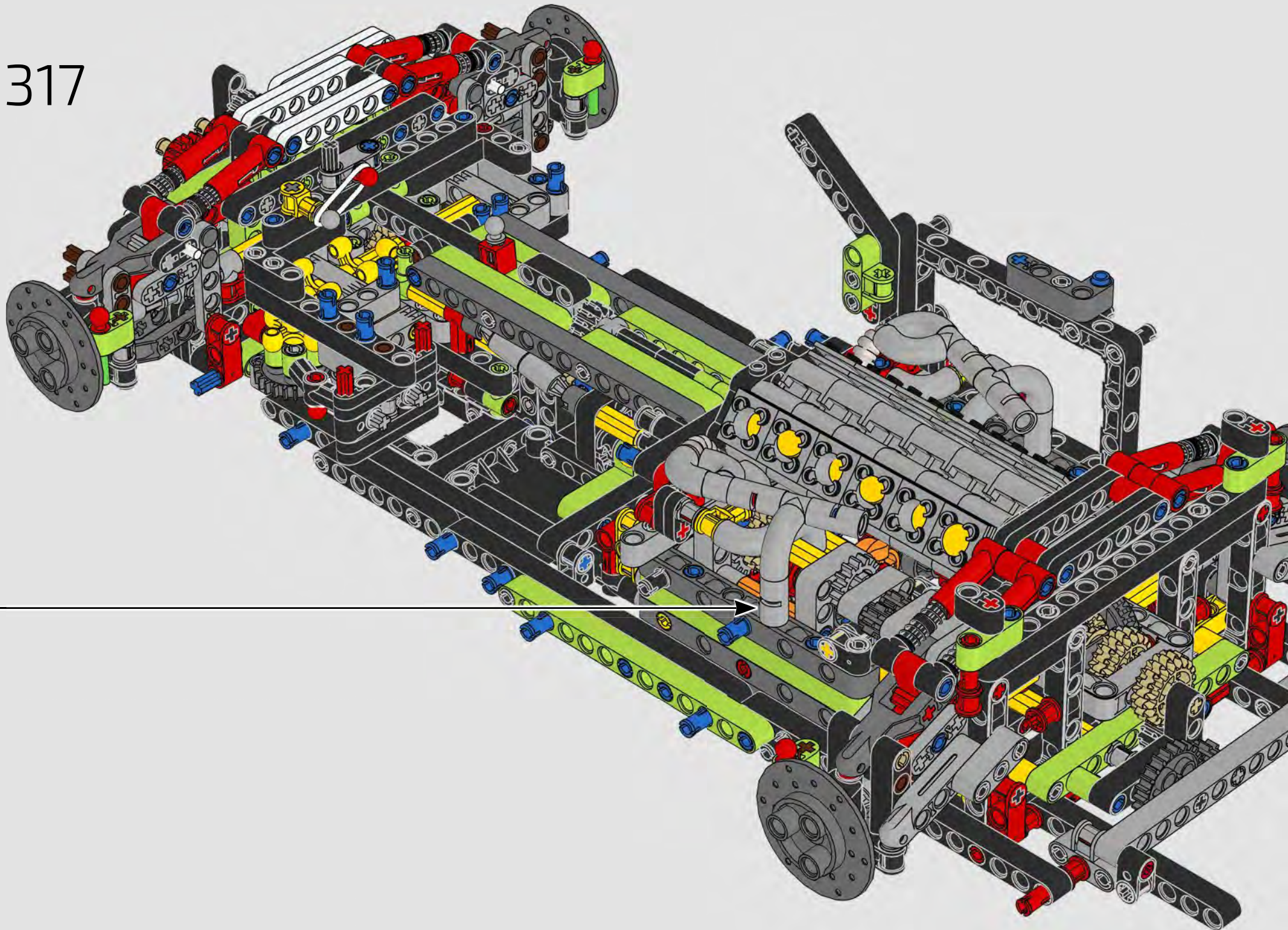

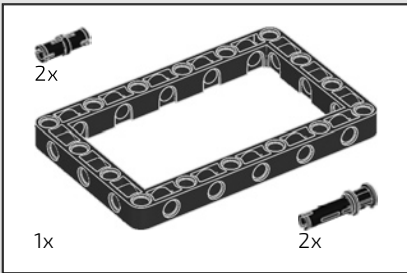

318

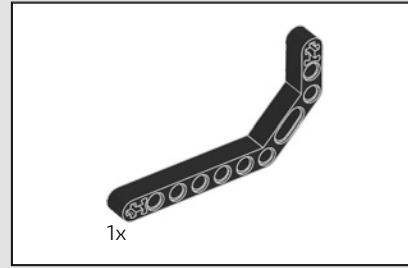
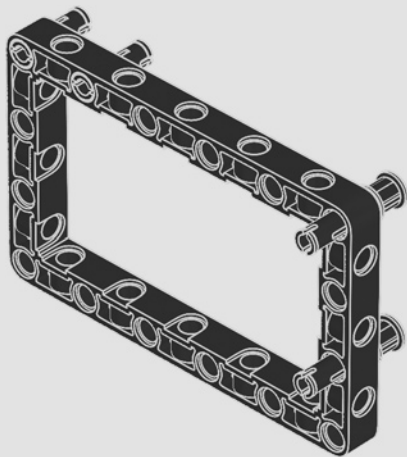

319

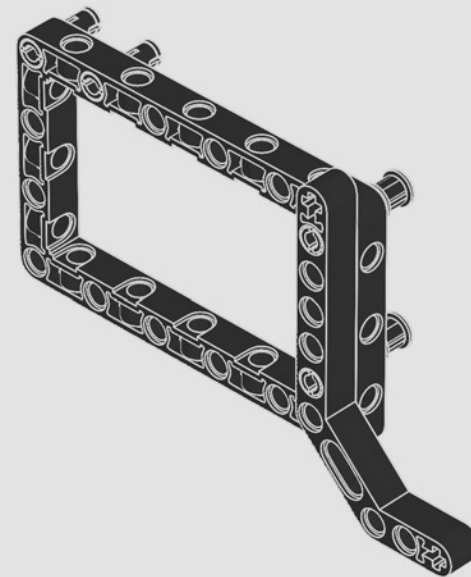

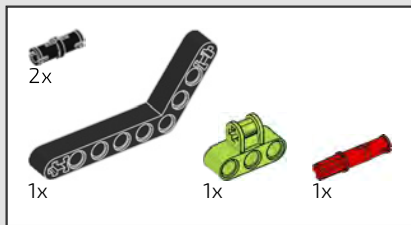

320

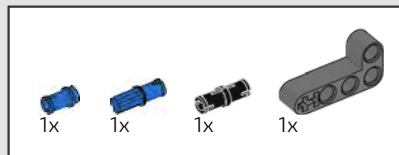
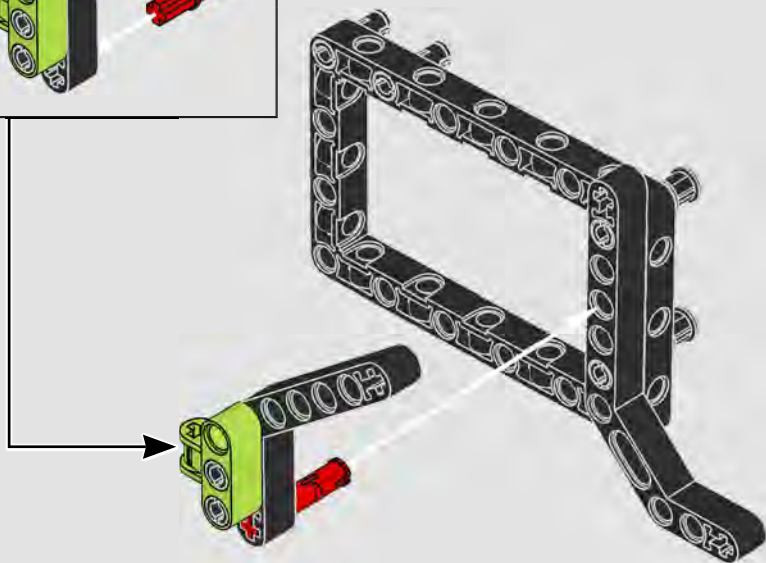
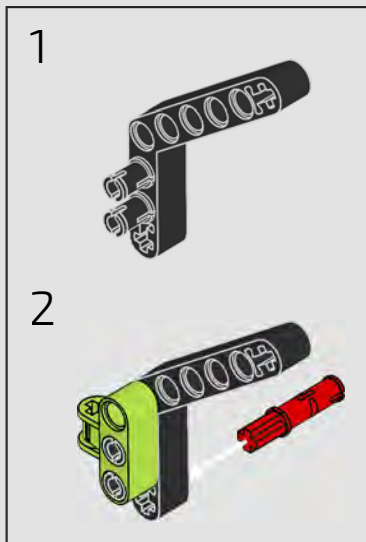

321

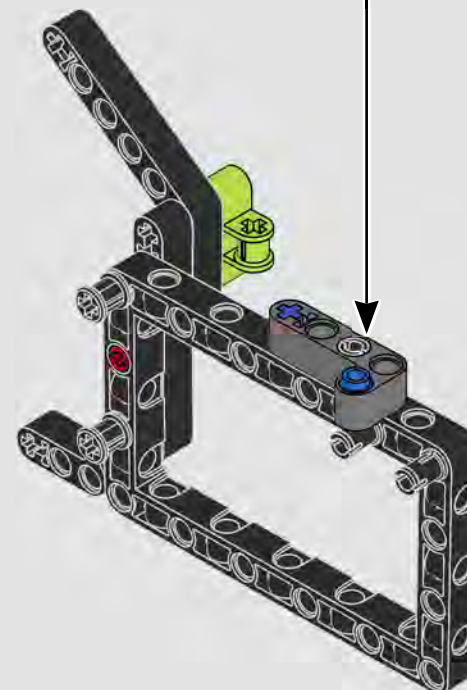
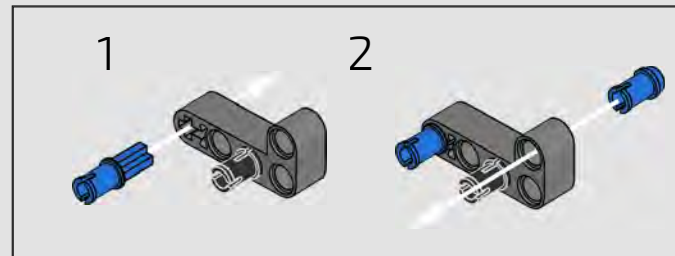

322

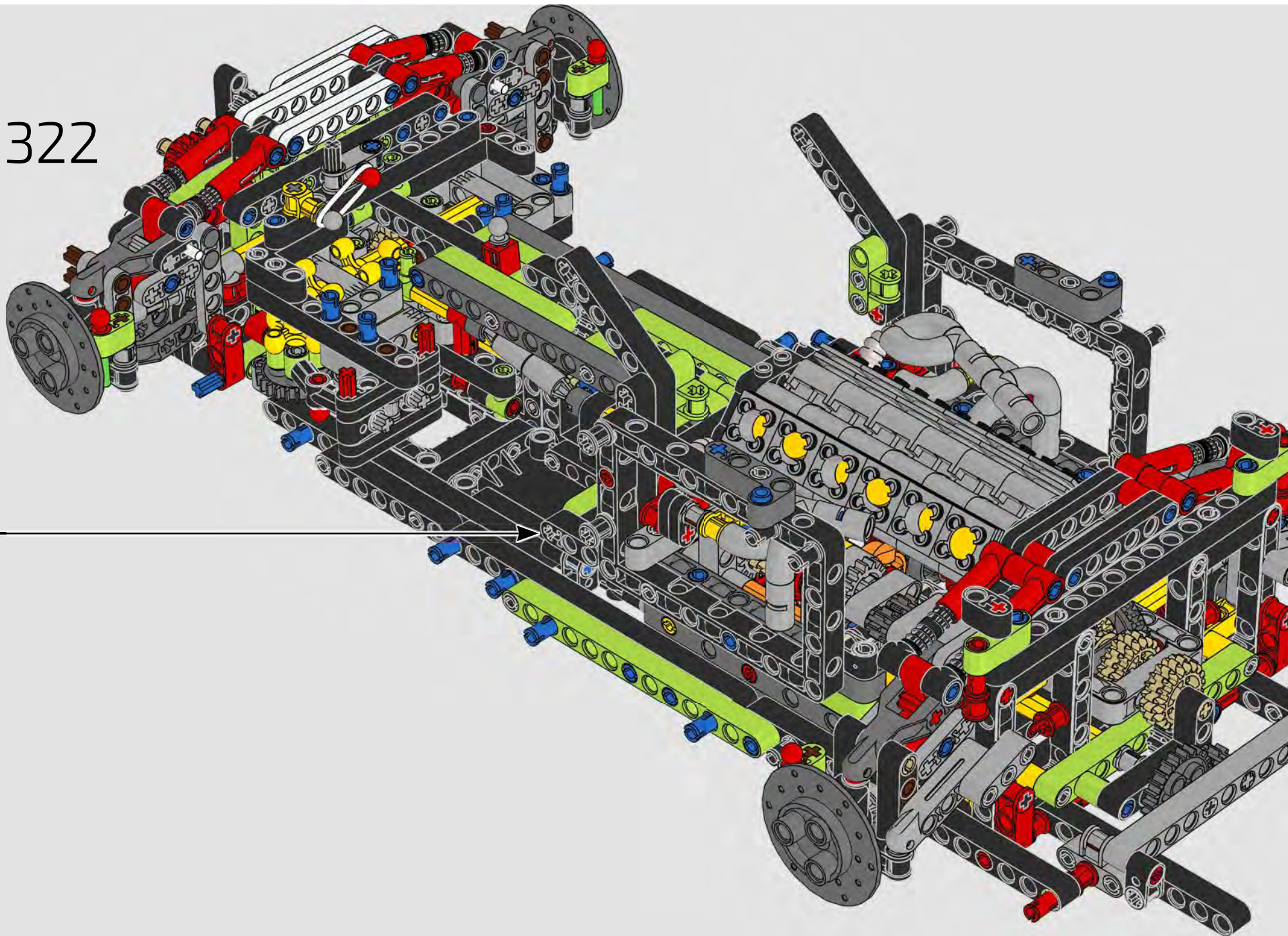

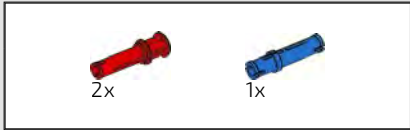

323

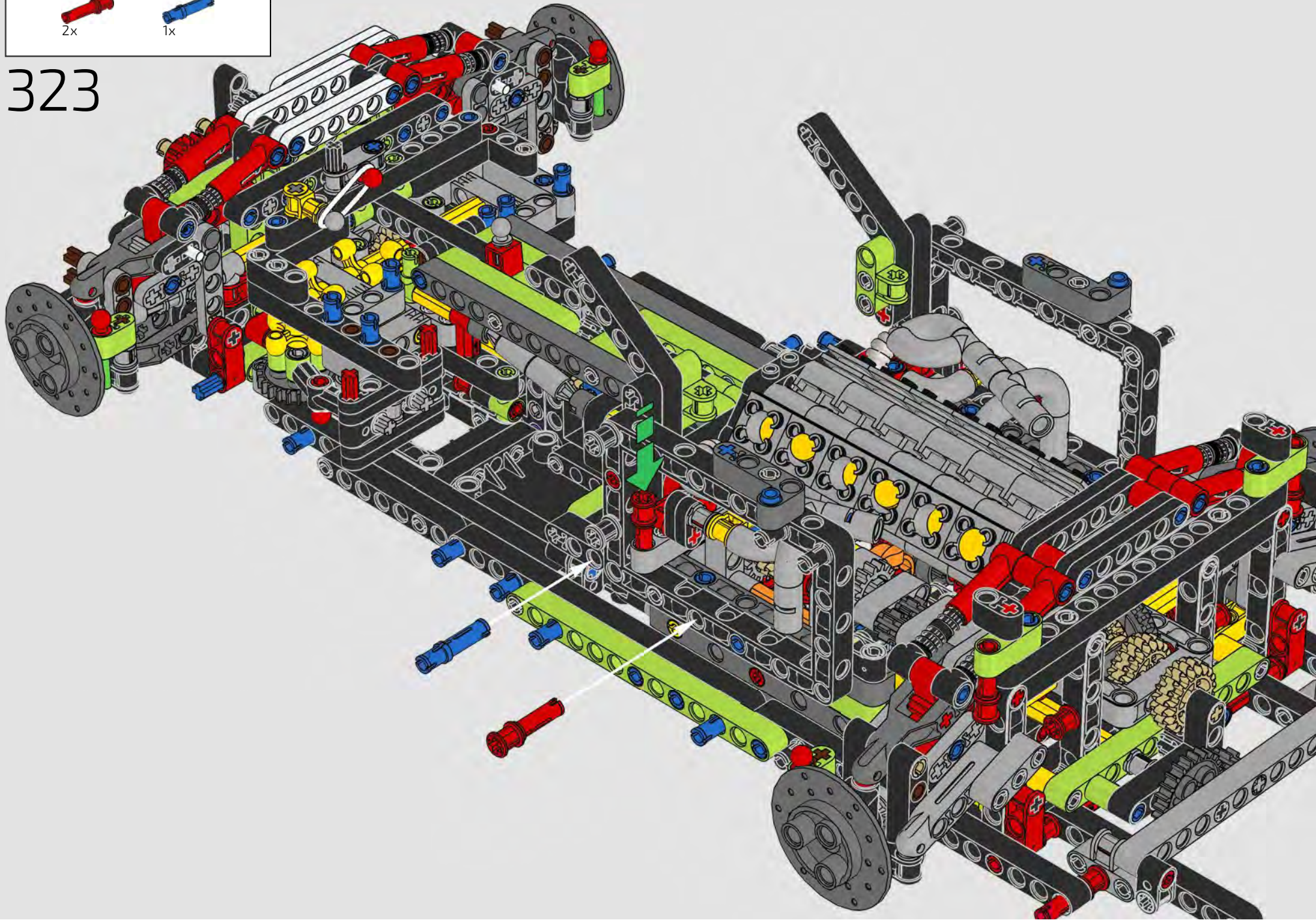

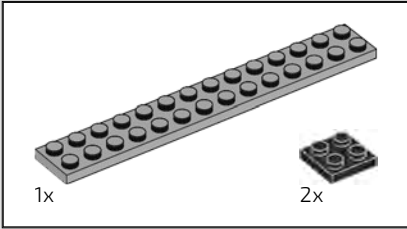
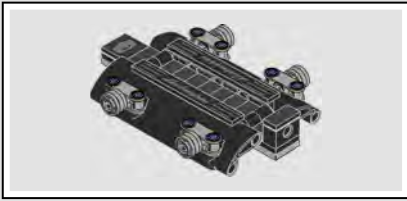

324

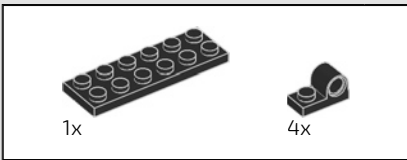
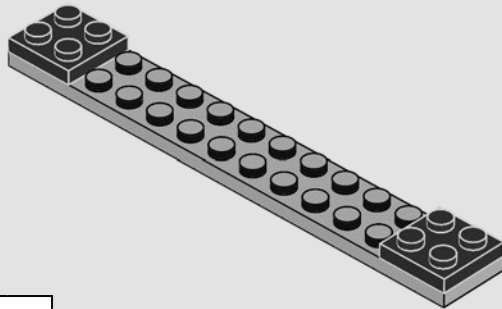

325

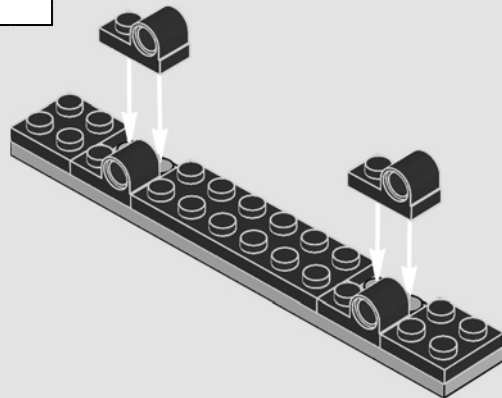

326

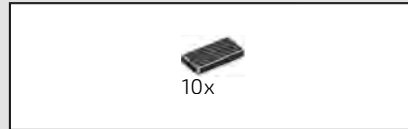
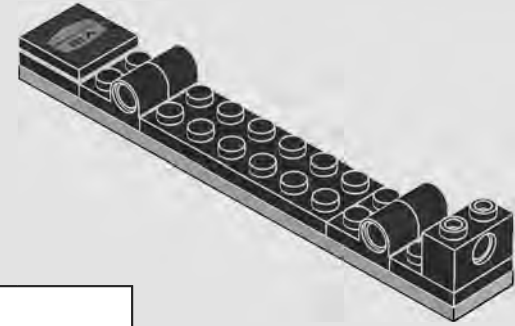

327

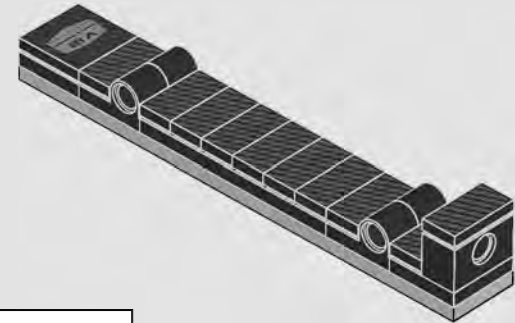

328

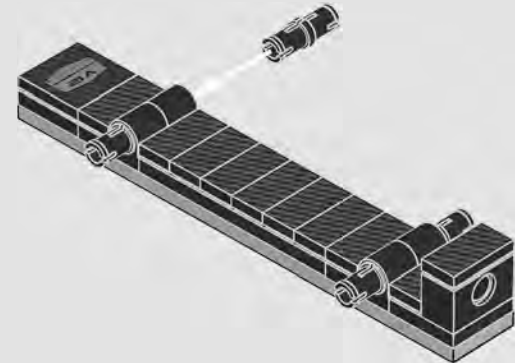

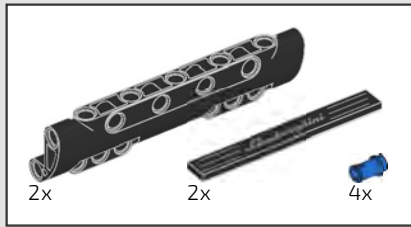

329

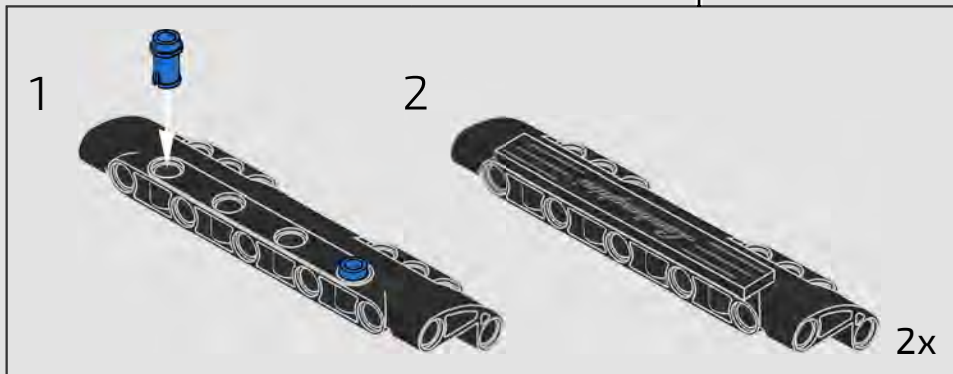
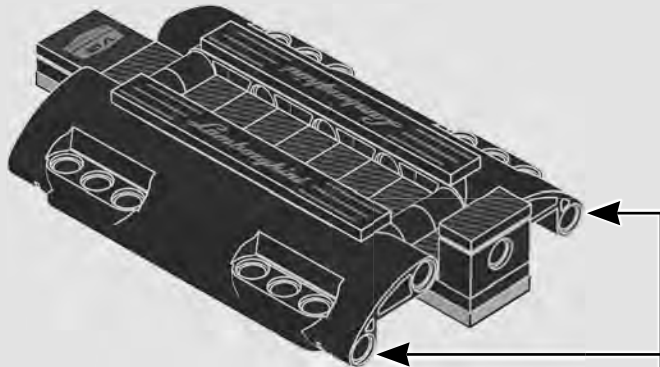

330

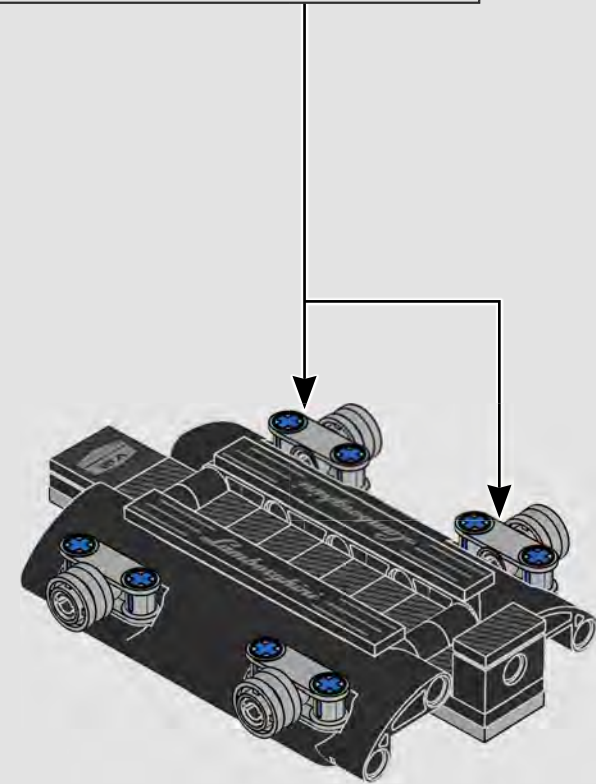

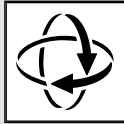

331

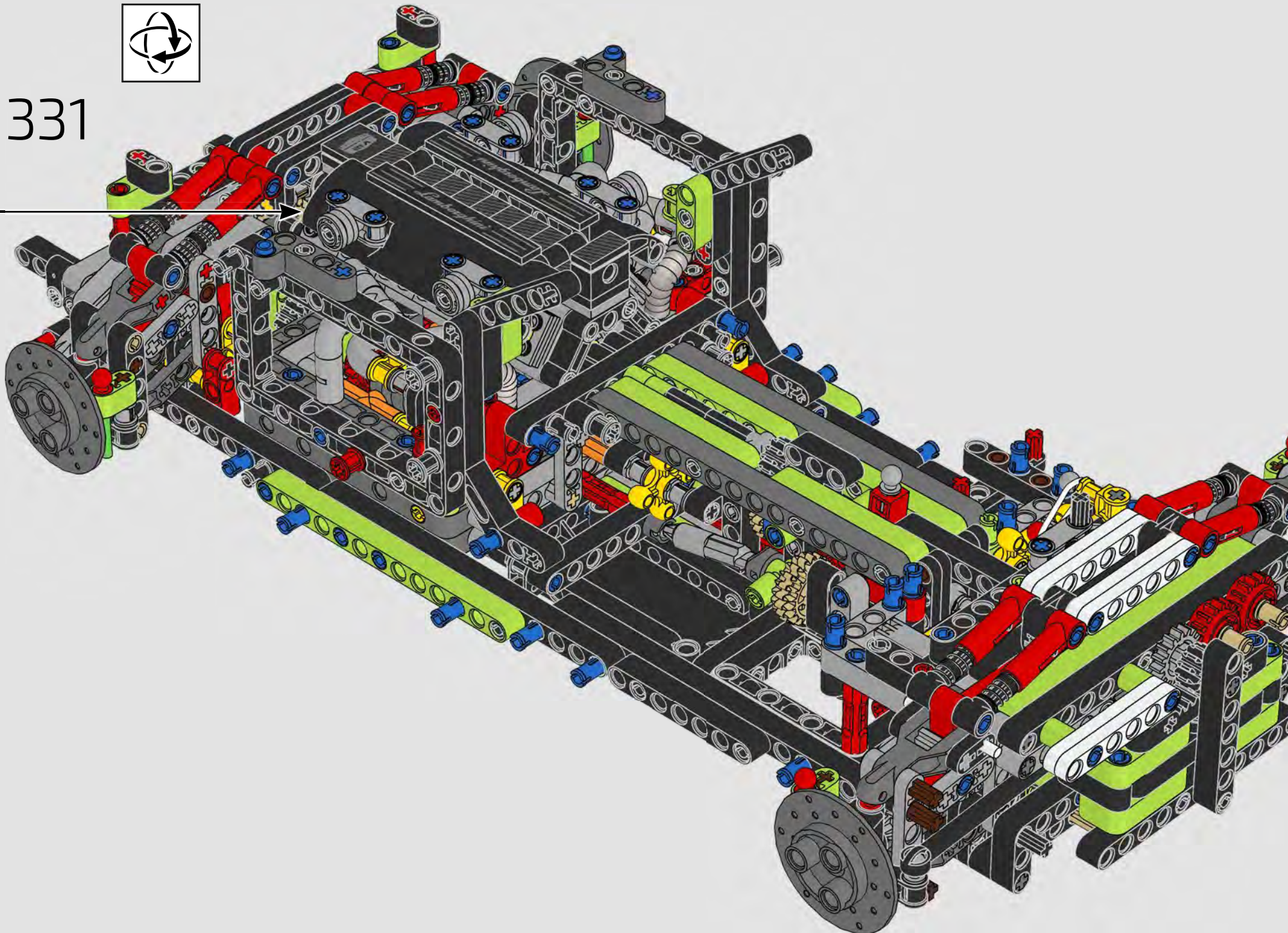

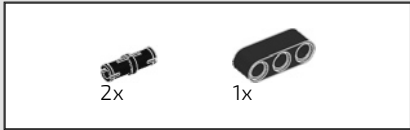

332

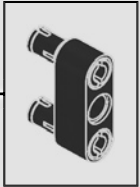
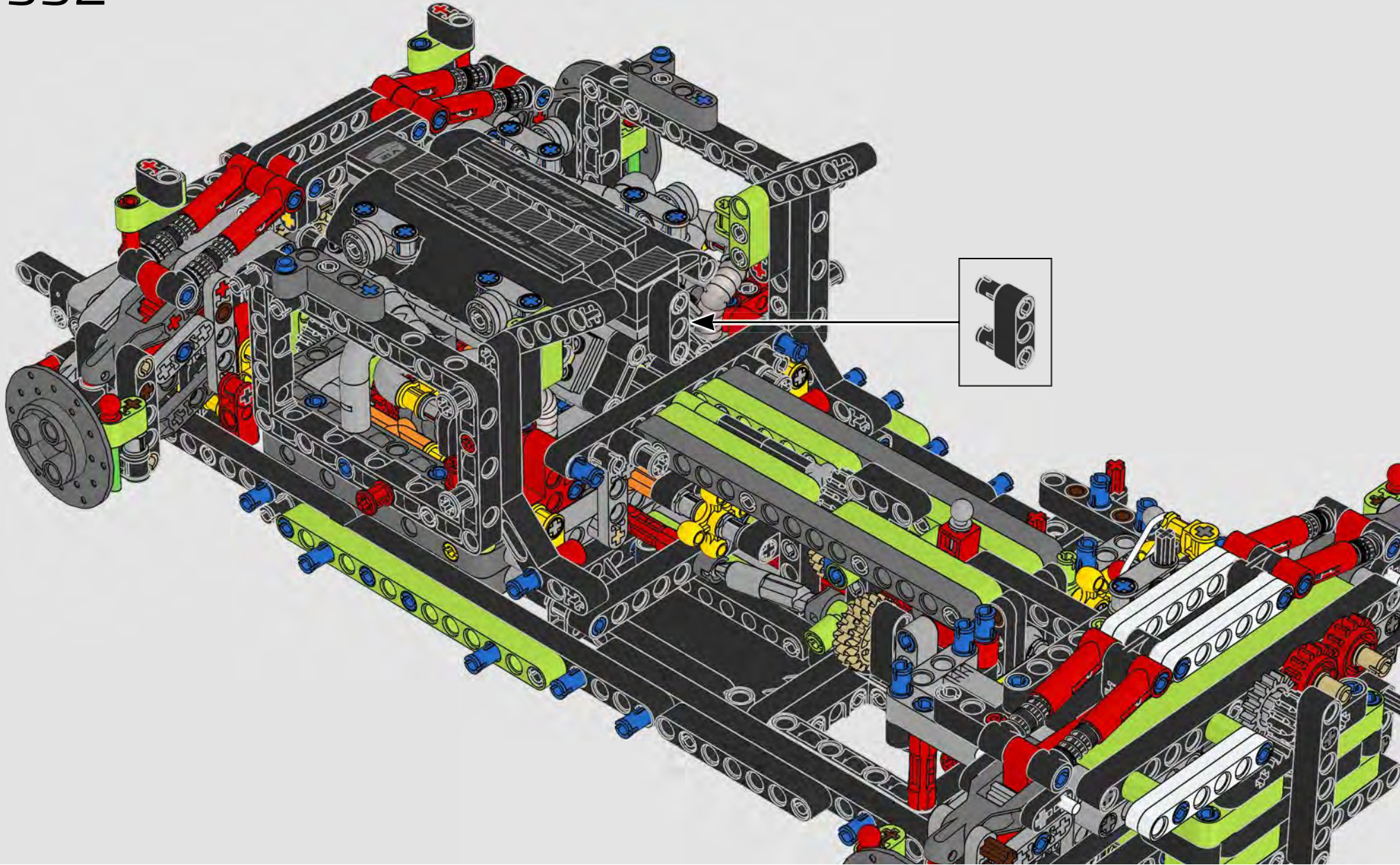



333

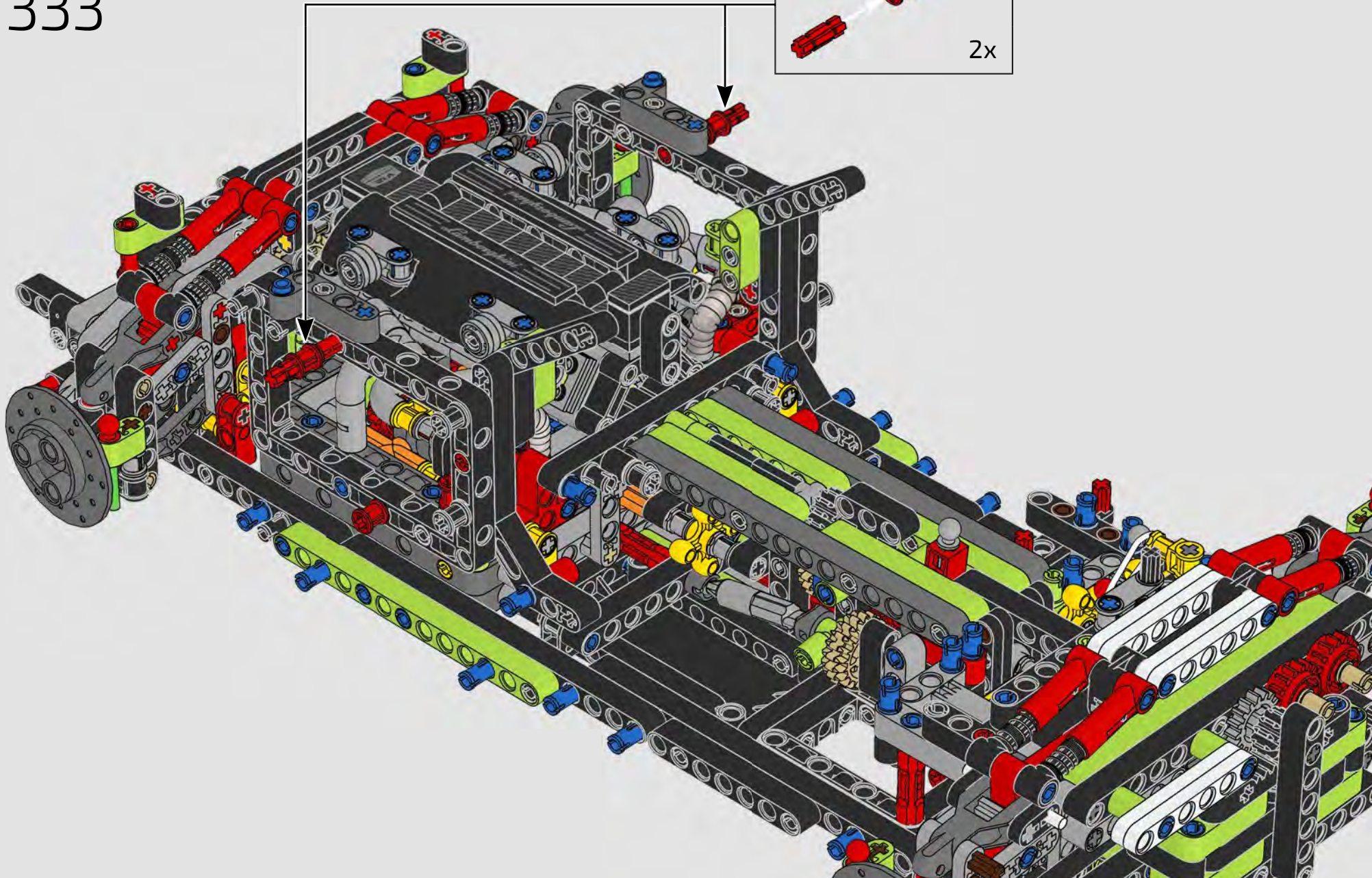
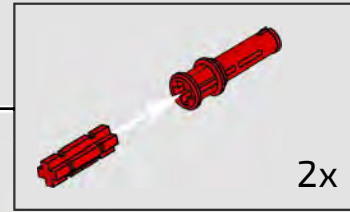

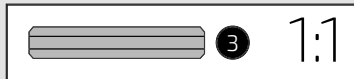
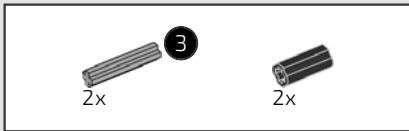

334

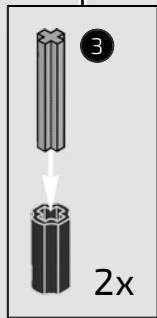
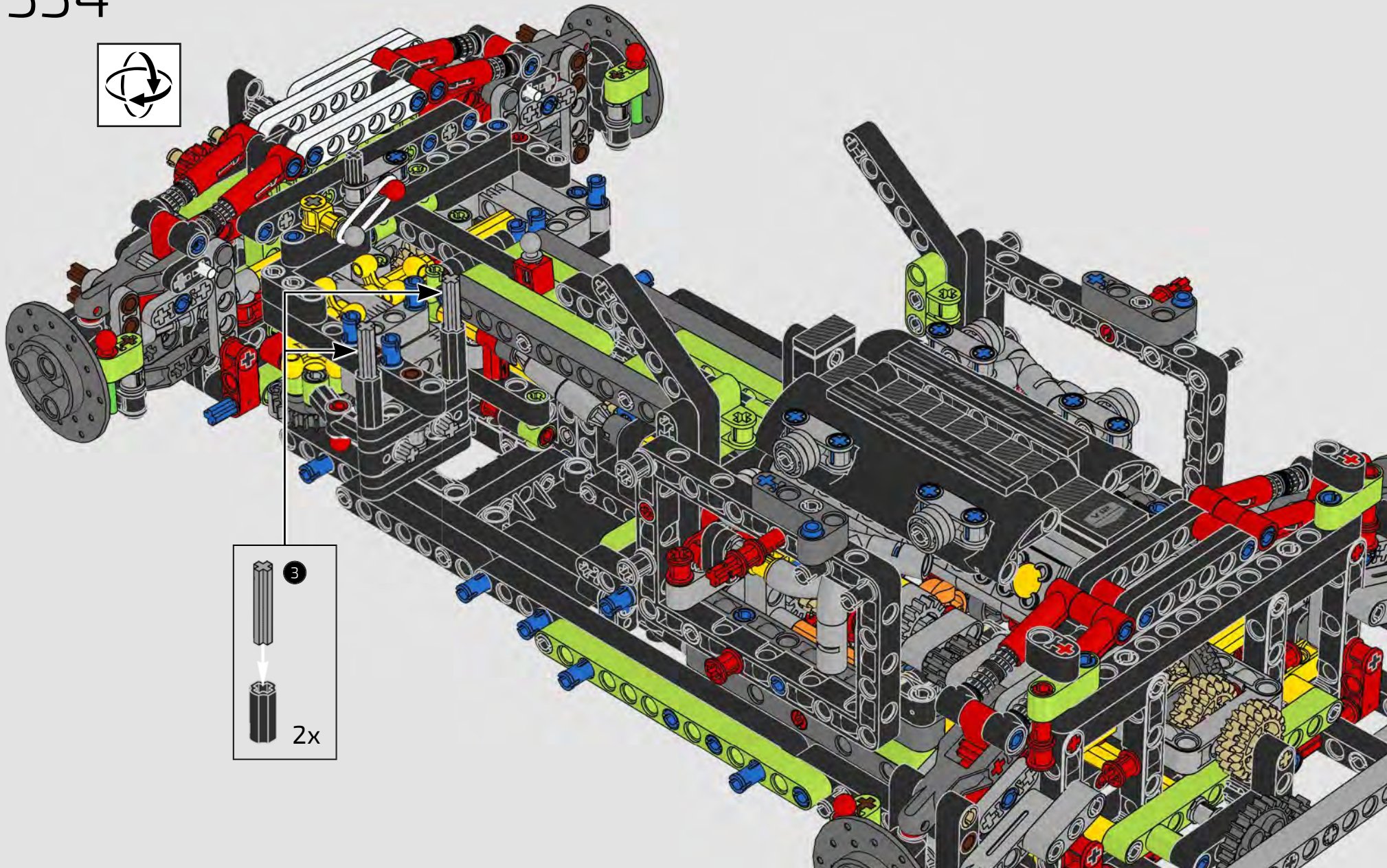

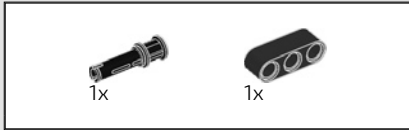

335

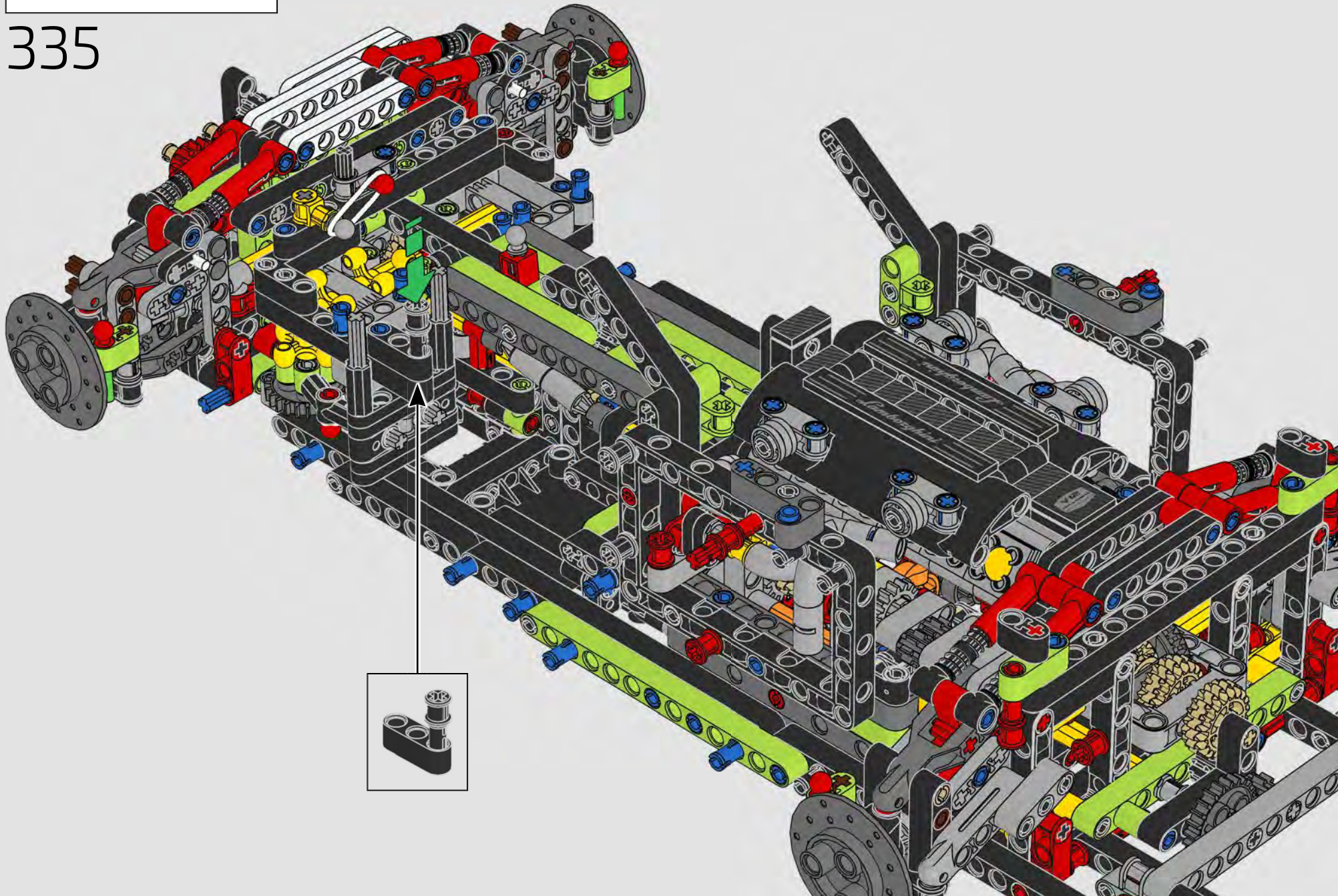



336

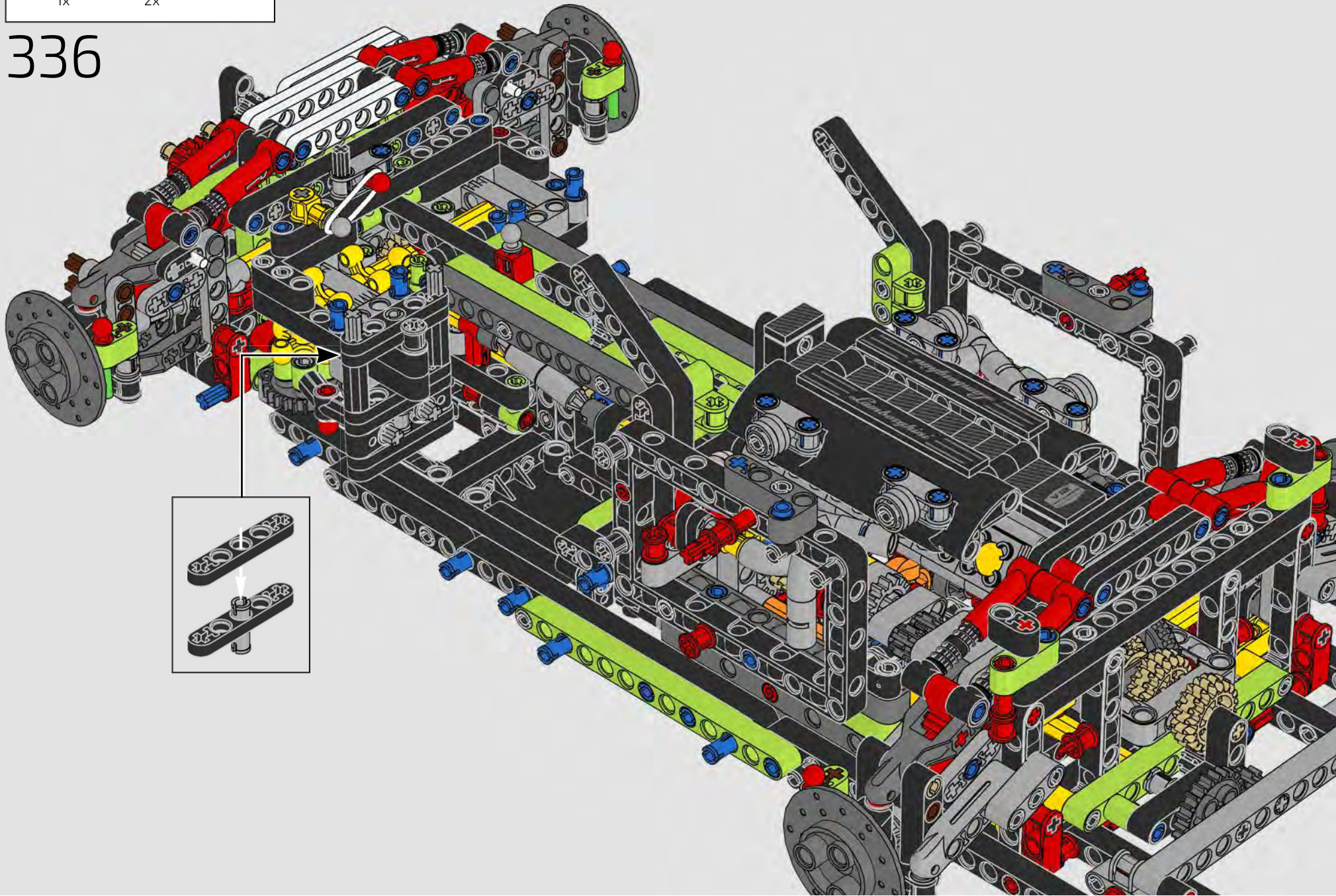

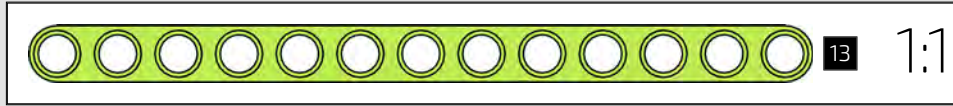
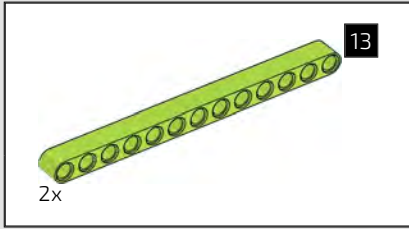

337

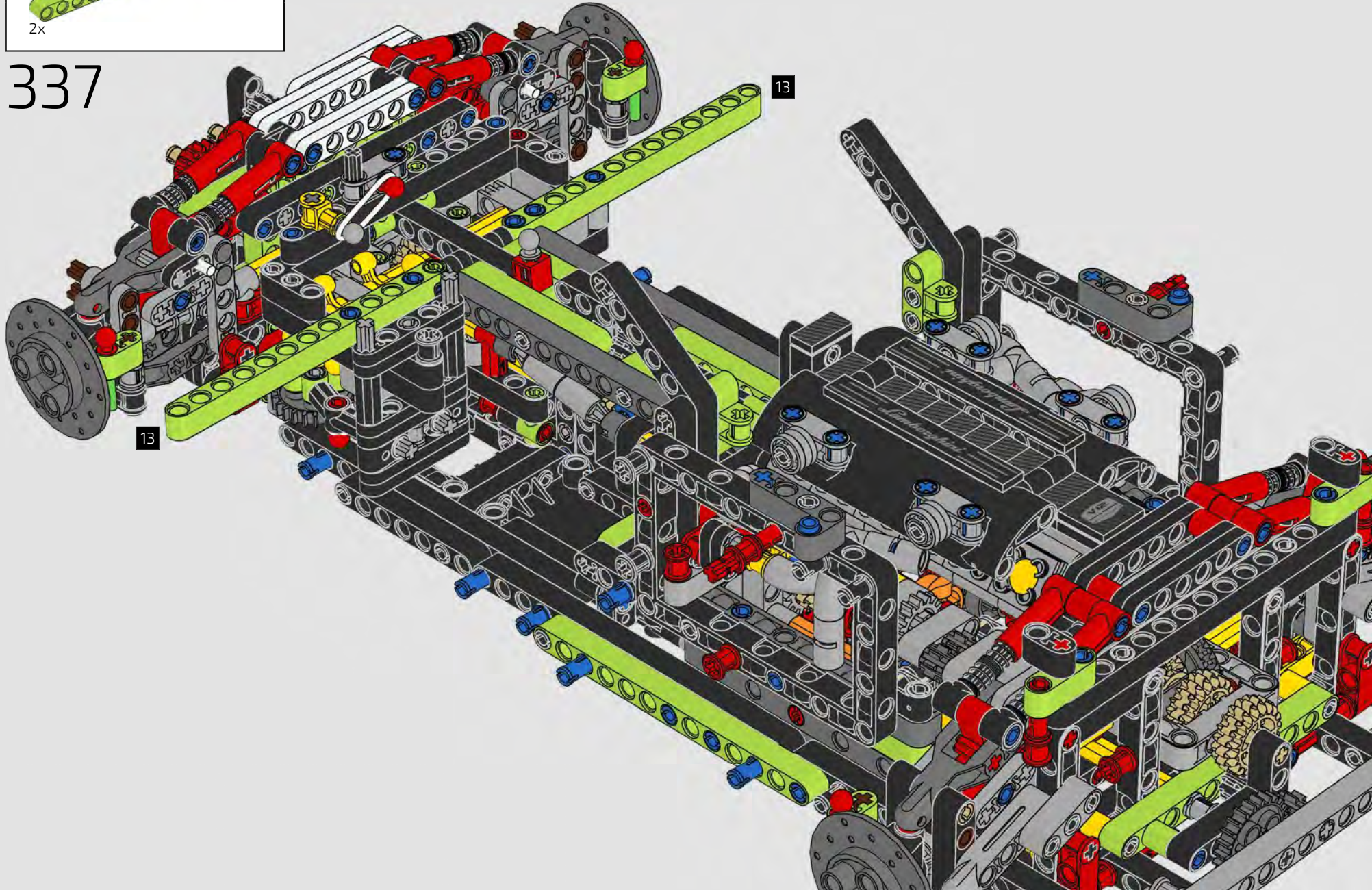

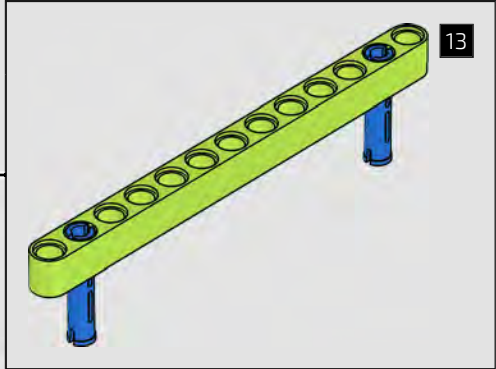
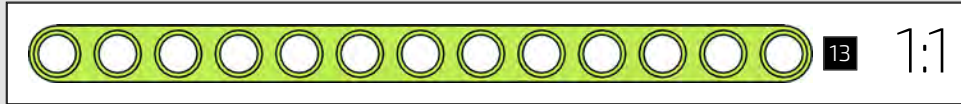
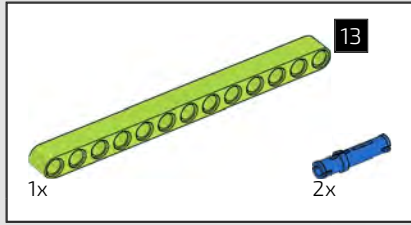

338

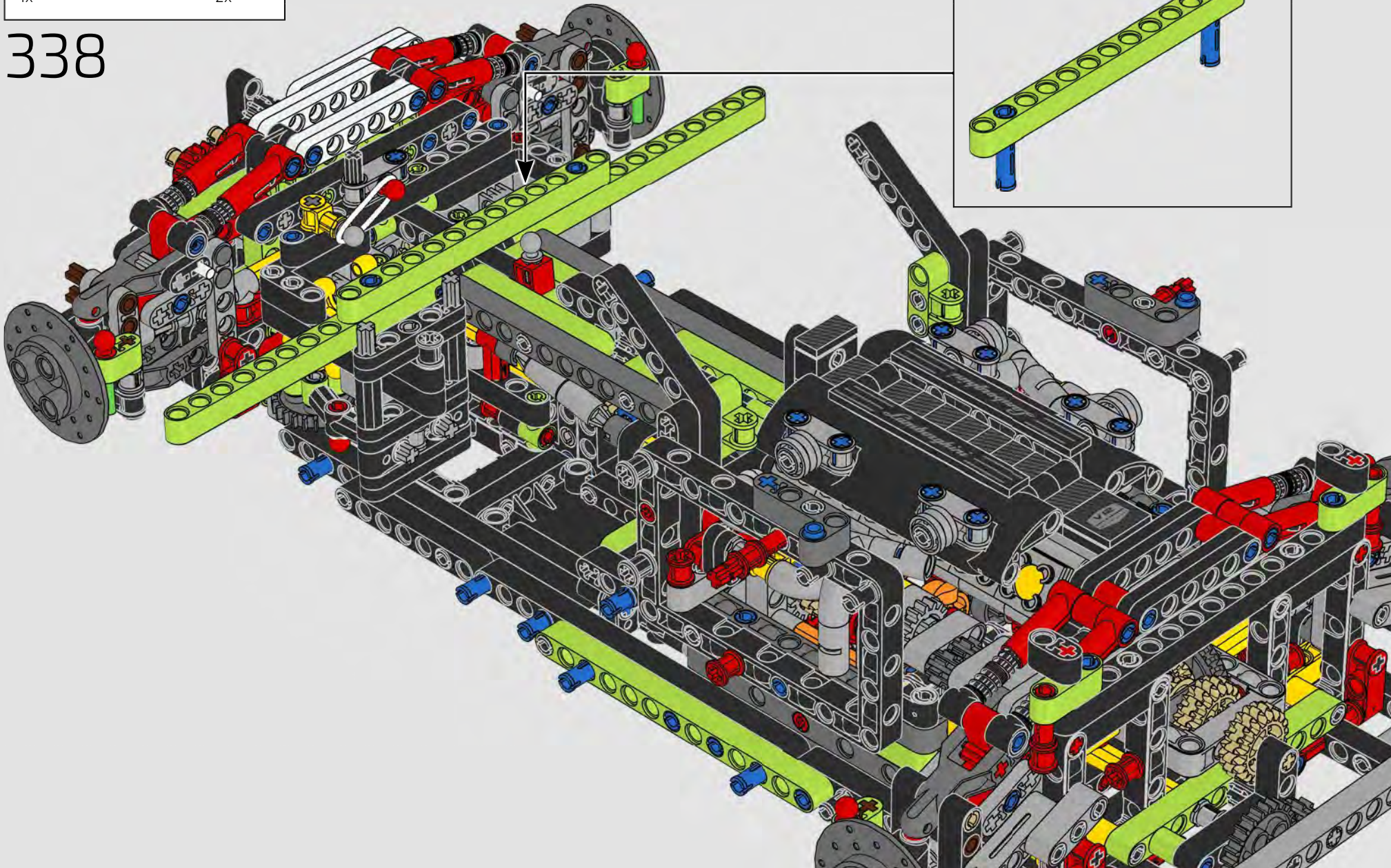

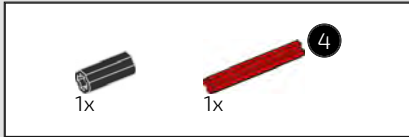

339

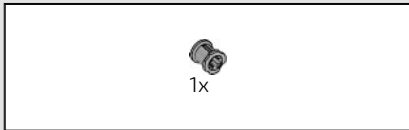
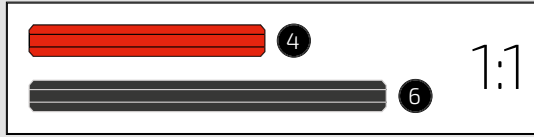

340

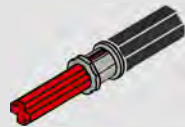

341

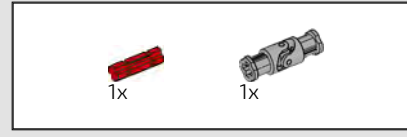
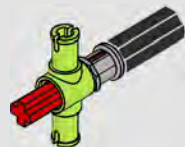

342

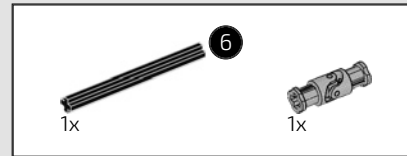
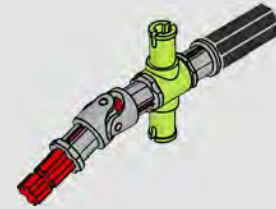

343

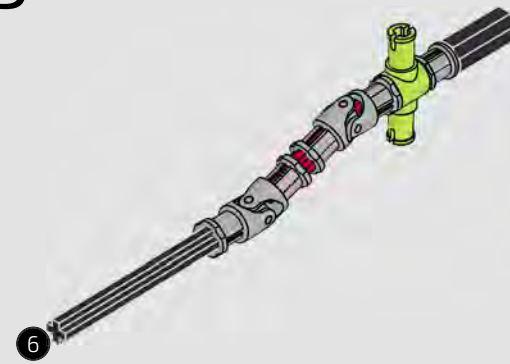

344

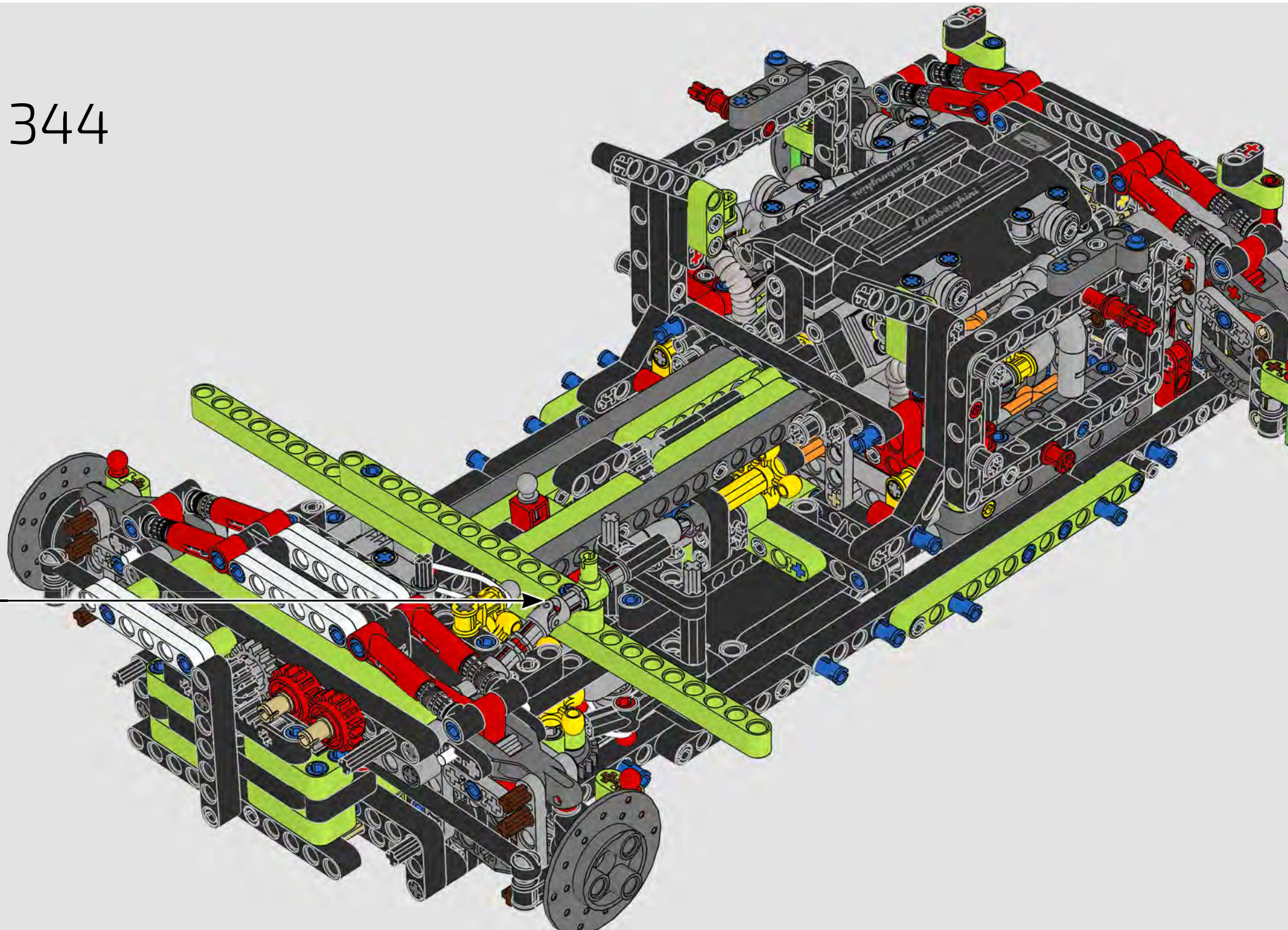

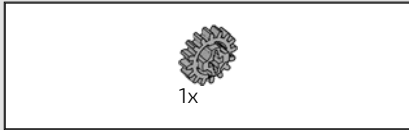

345

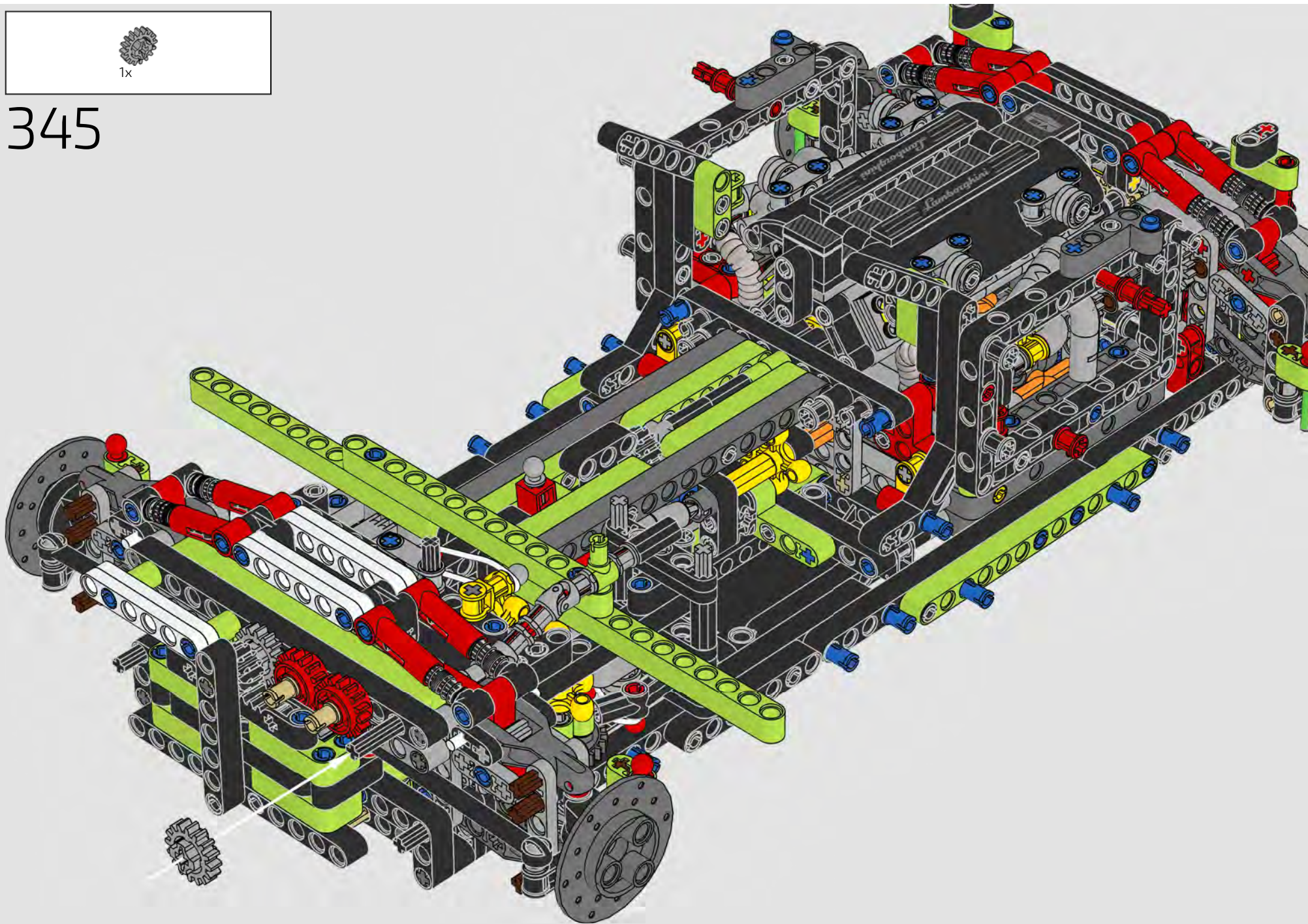

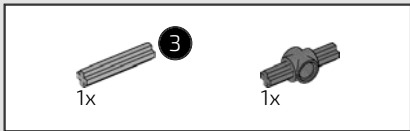

346

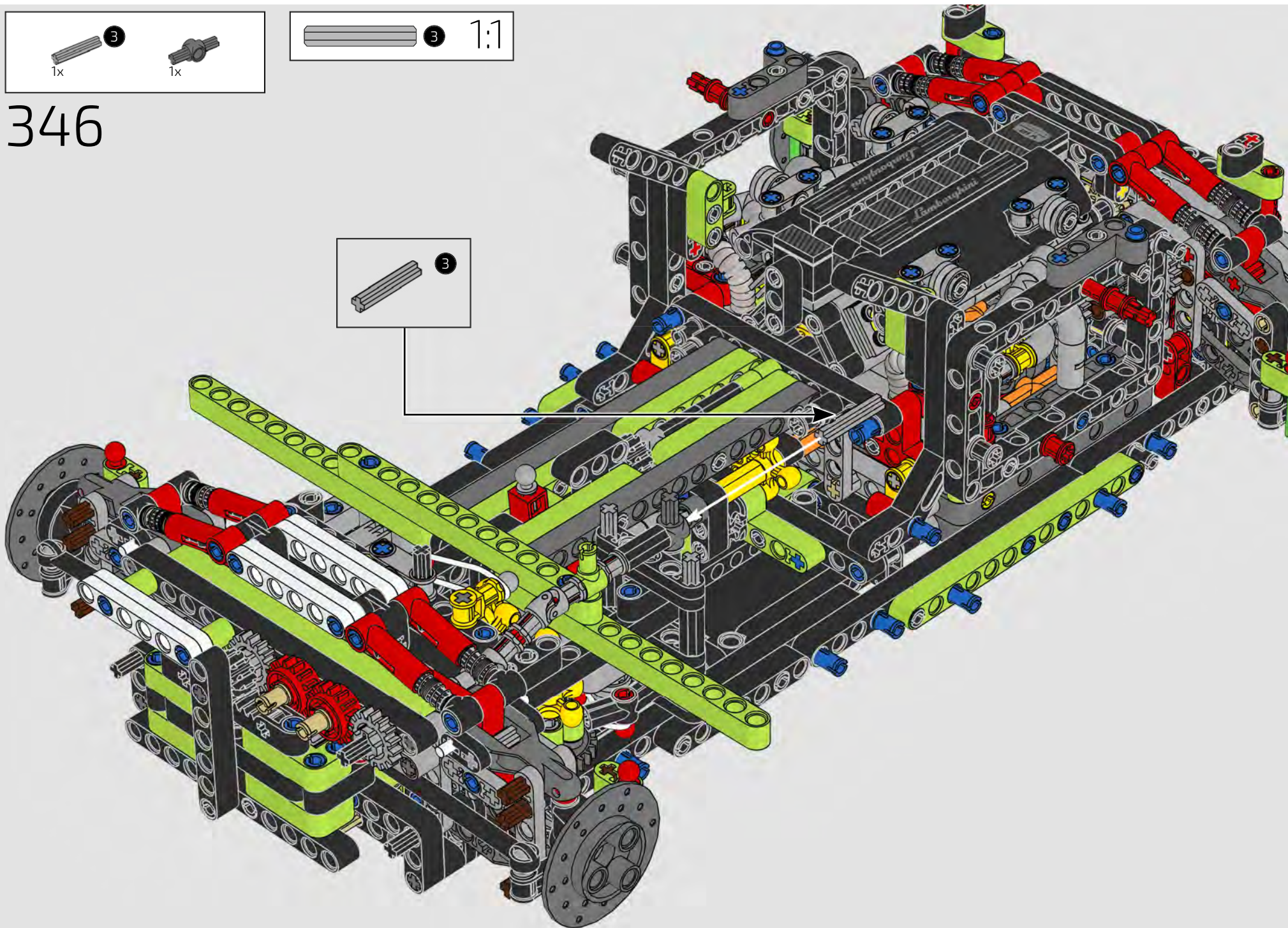
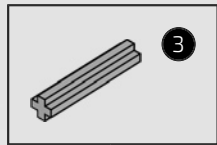

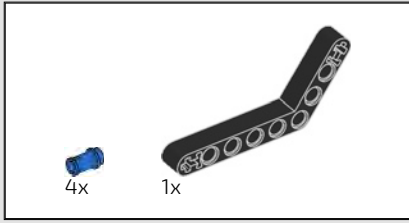

347

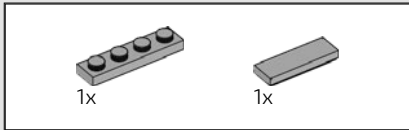
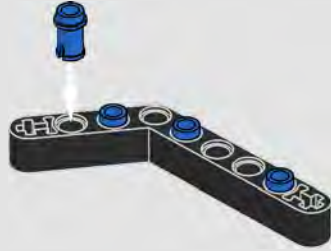

348

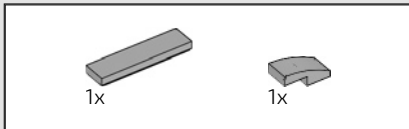
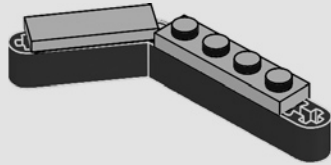

349

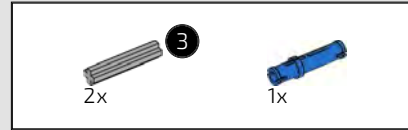
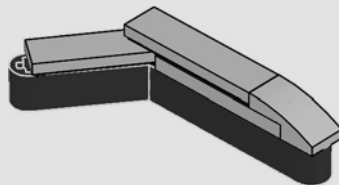

350

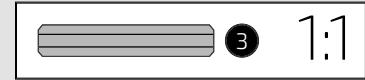
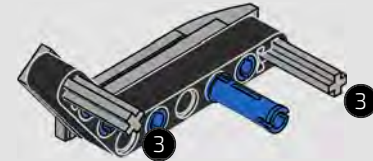
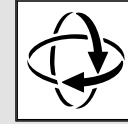

351

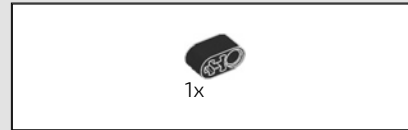

352

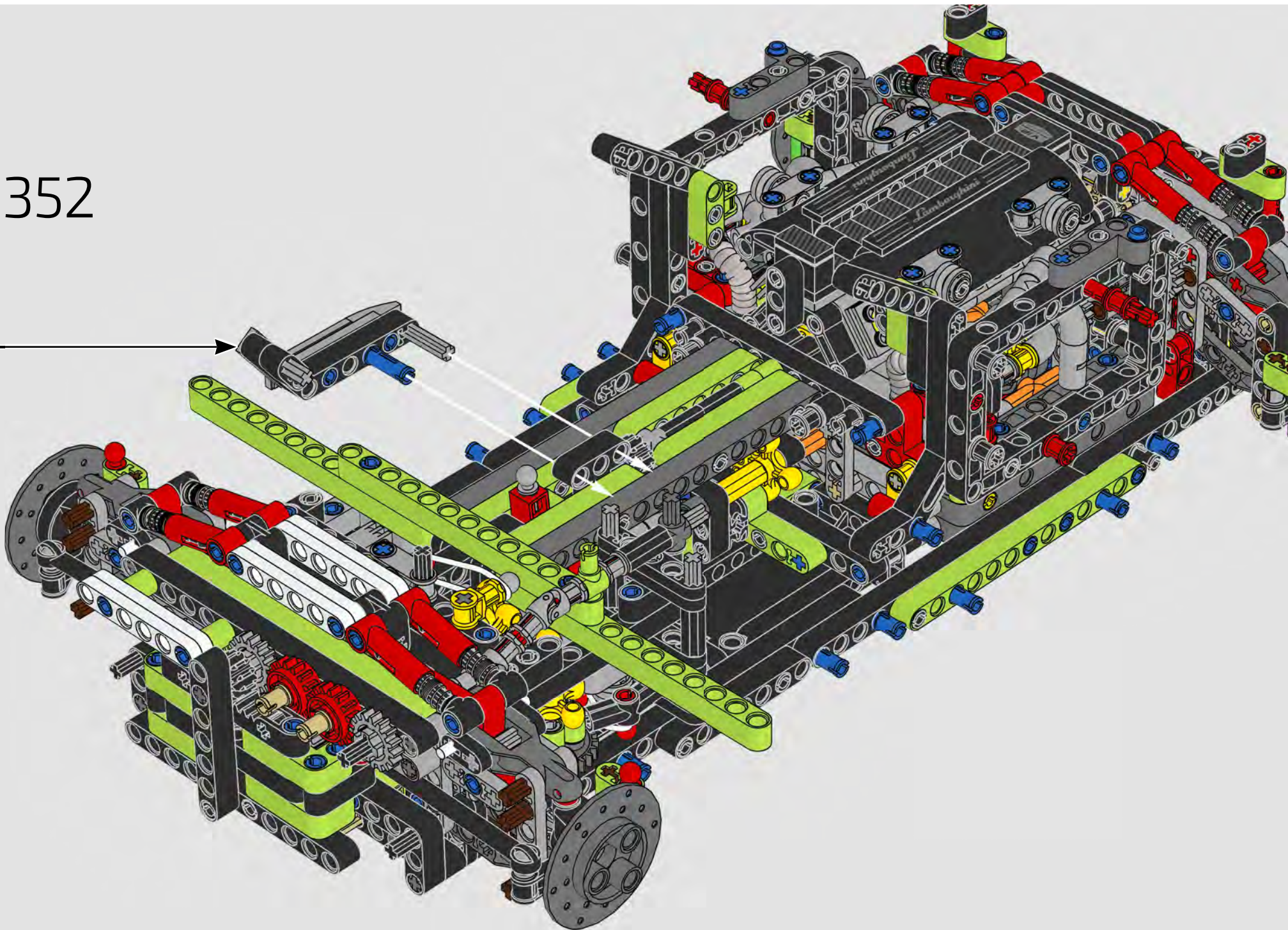

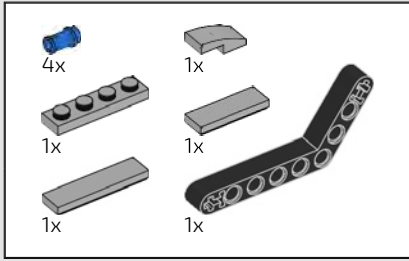

353

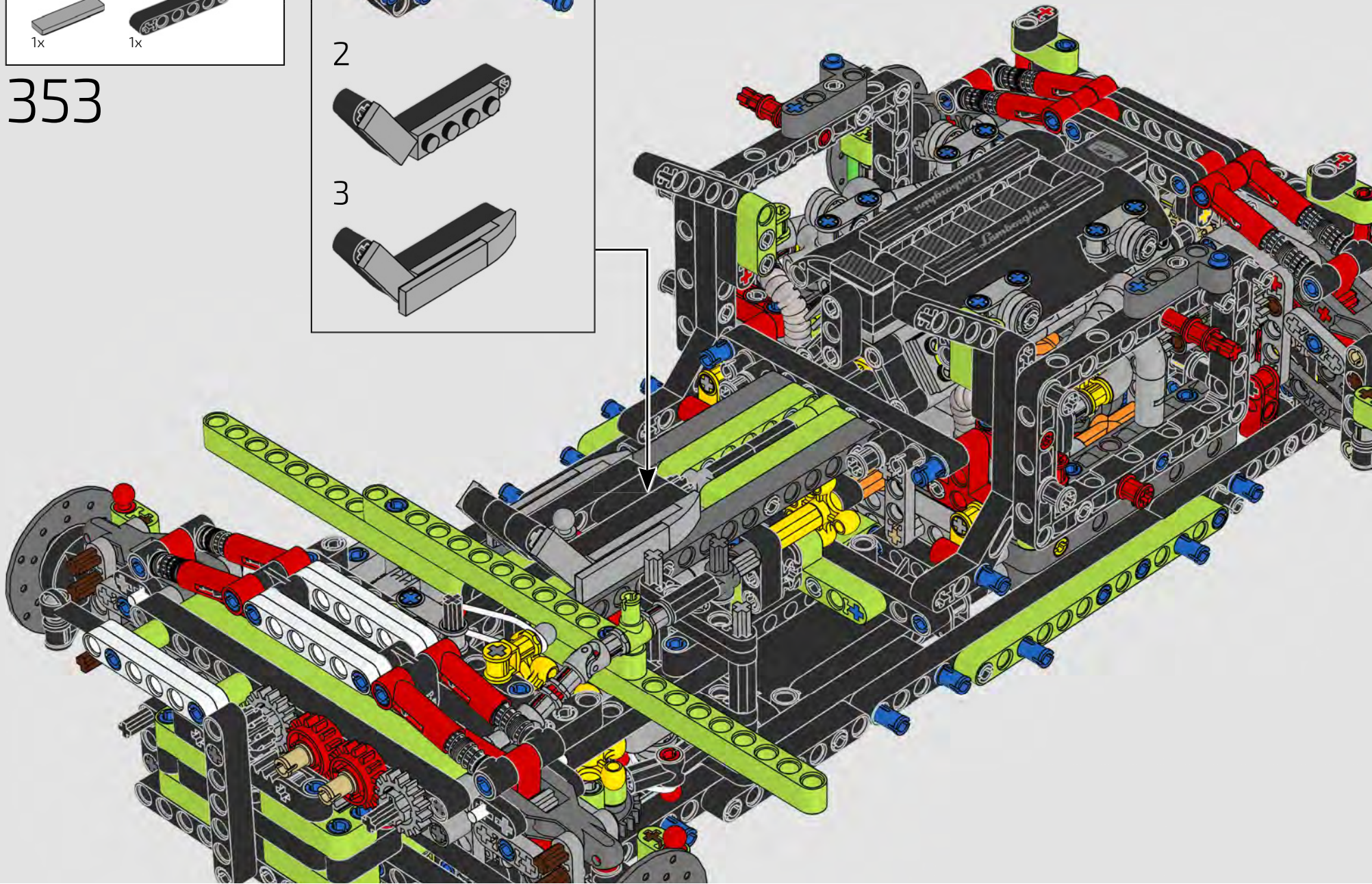
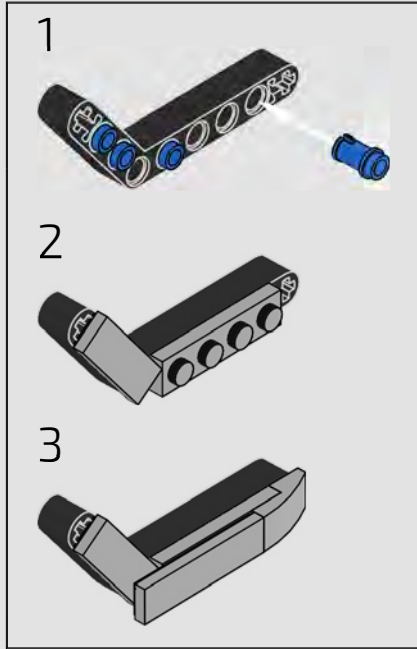

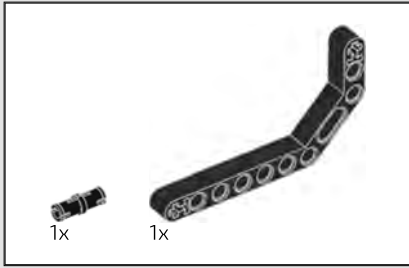

354

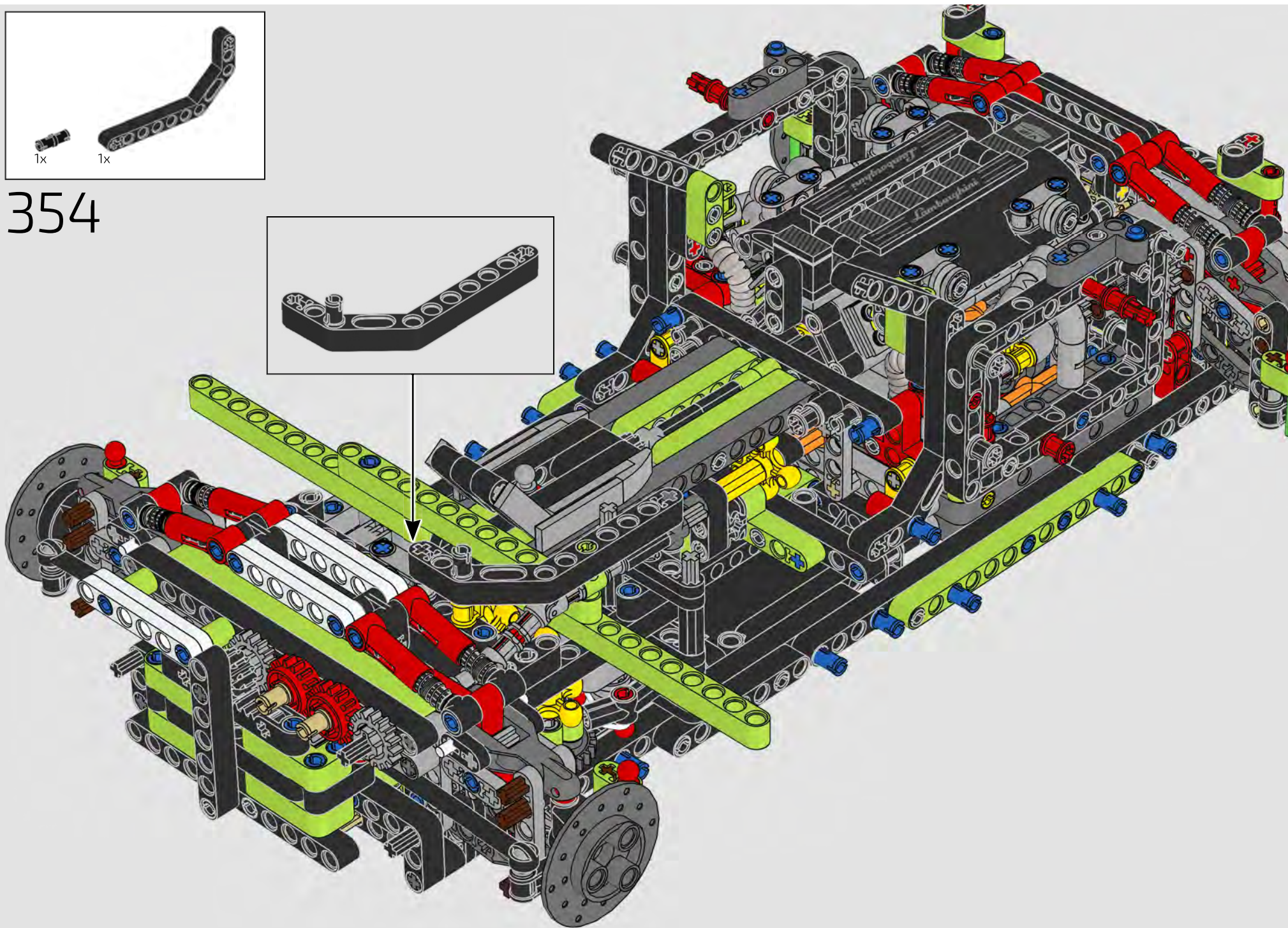
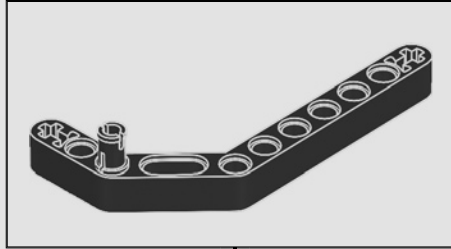

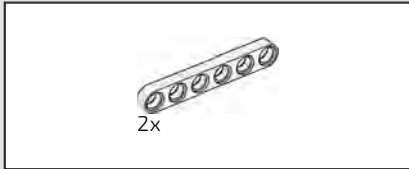

355

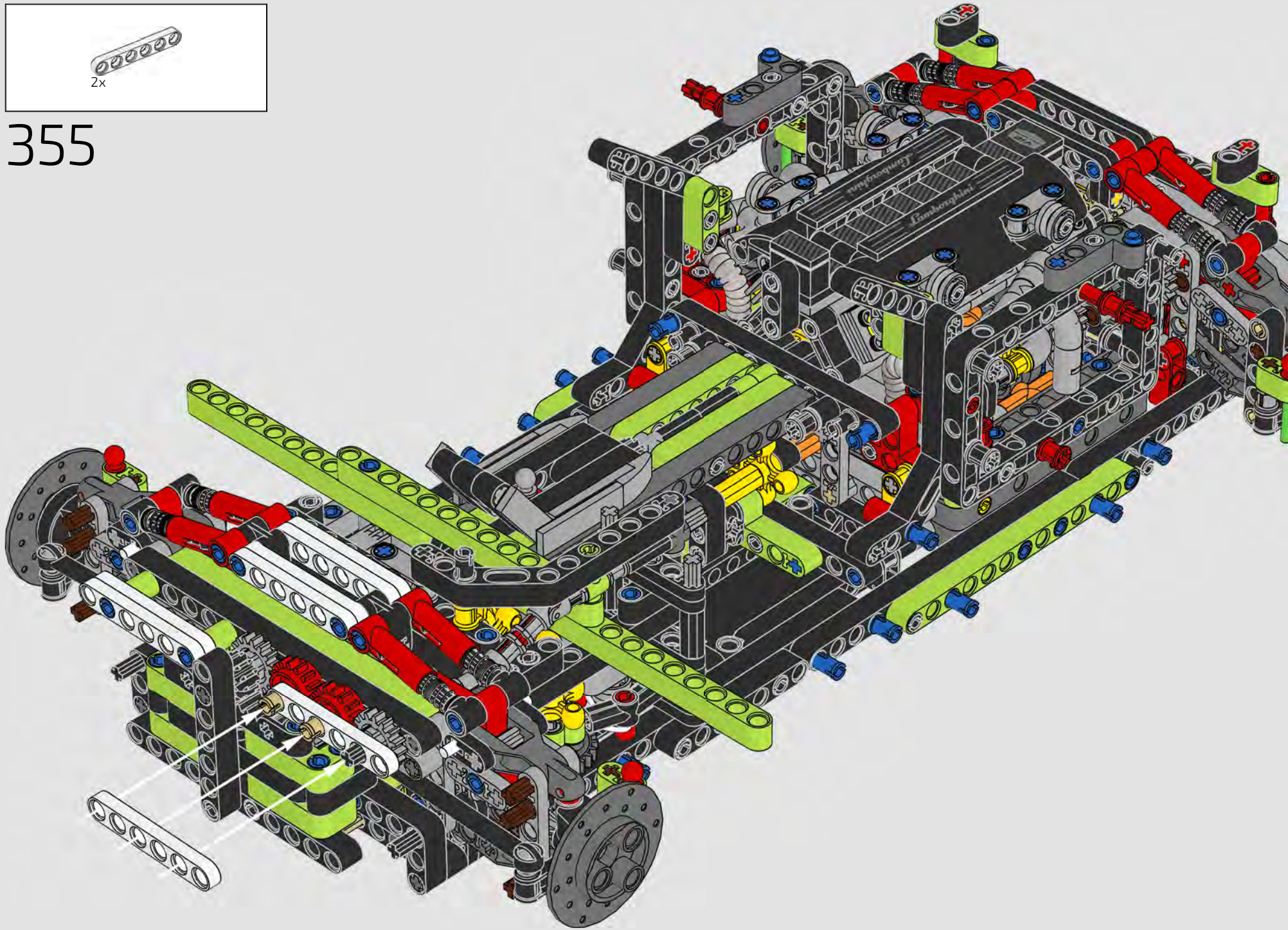

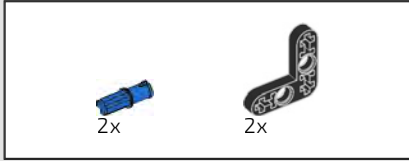
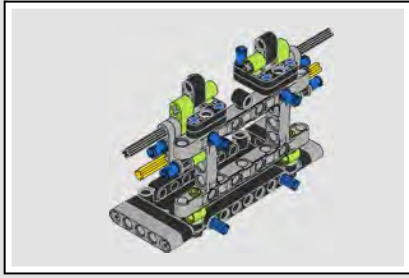

356



357



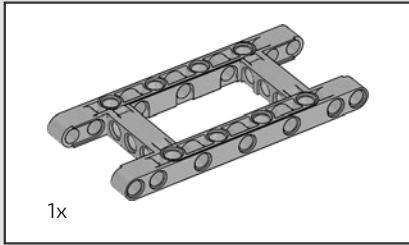

358

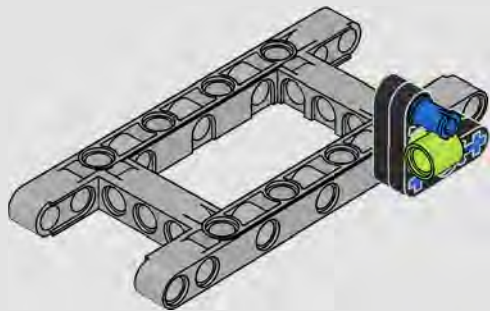

359

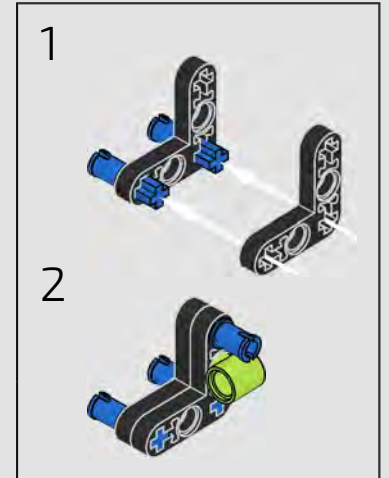
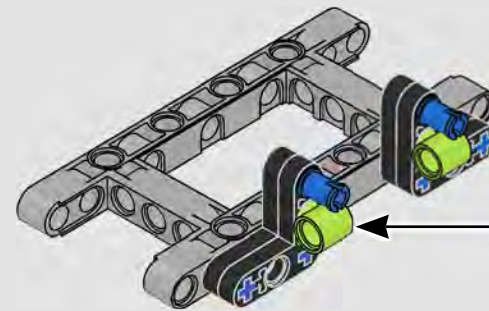



360

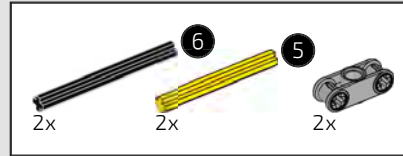
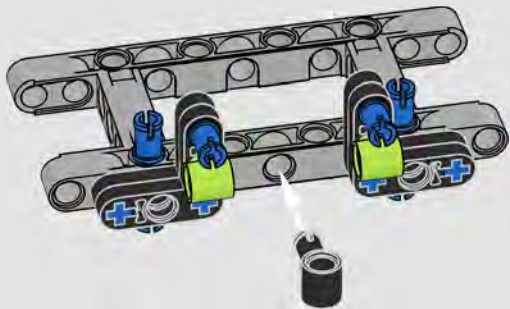

361

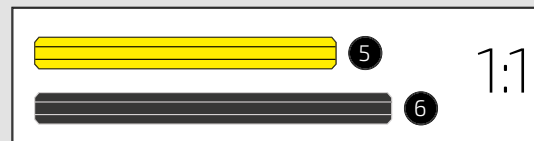
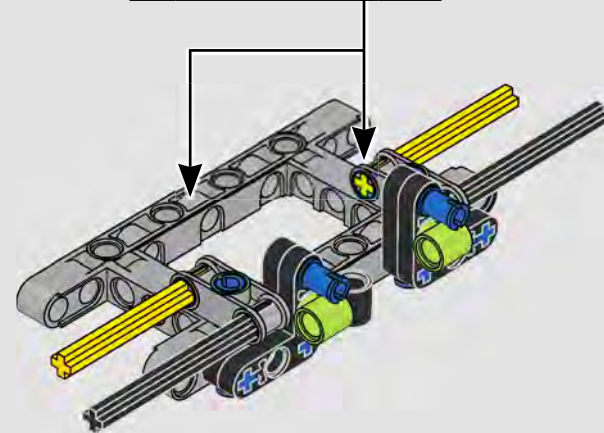
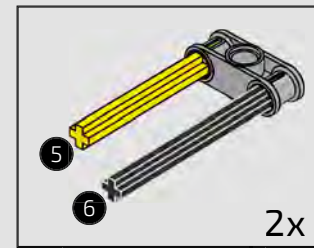

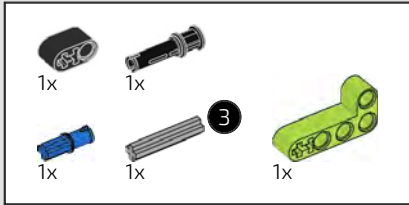

362

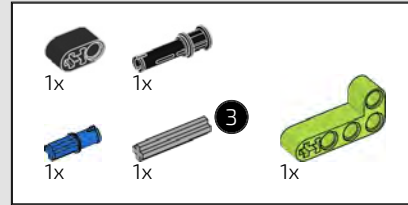
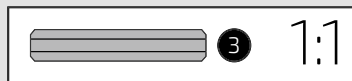
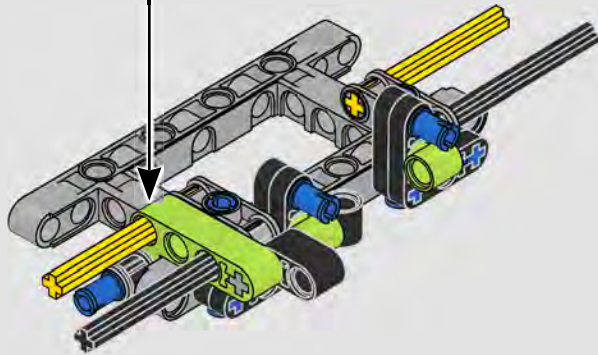
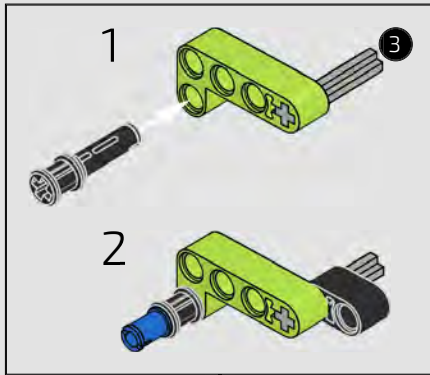

363

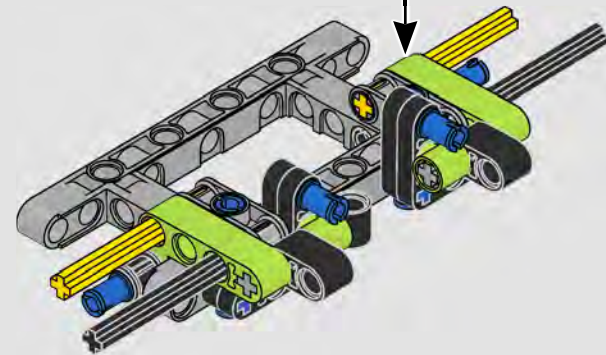
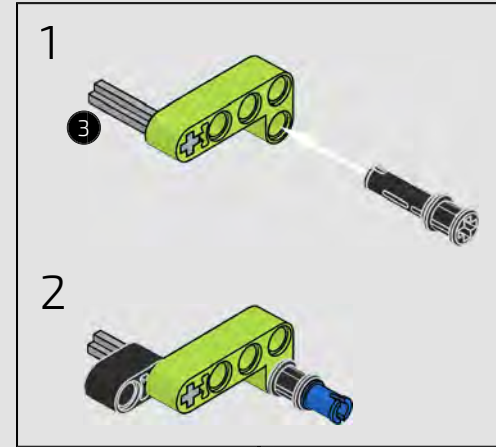

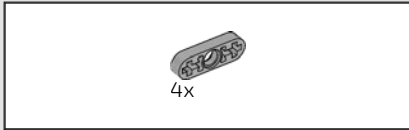

364

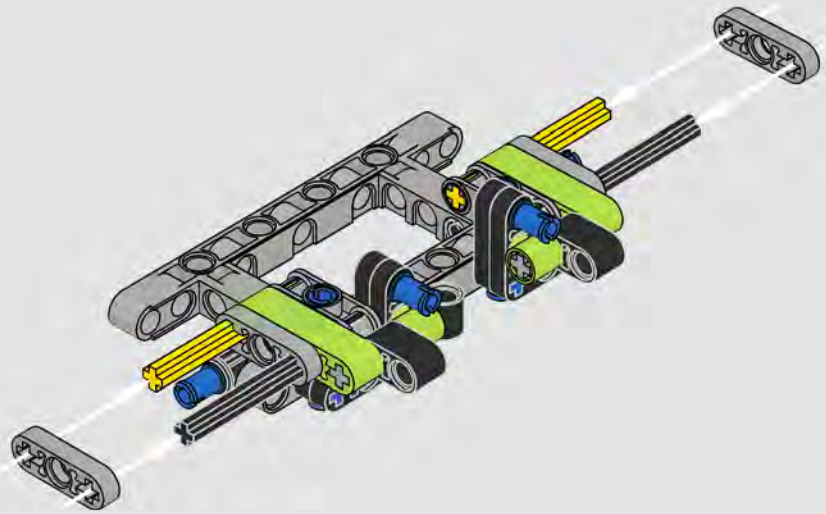

365

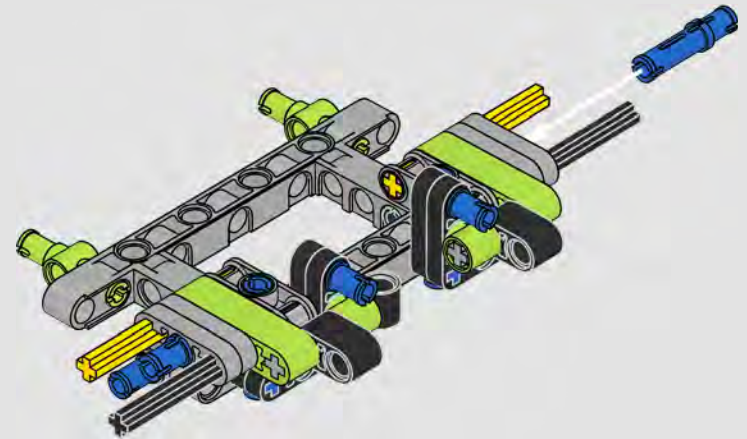

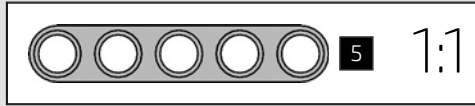
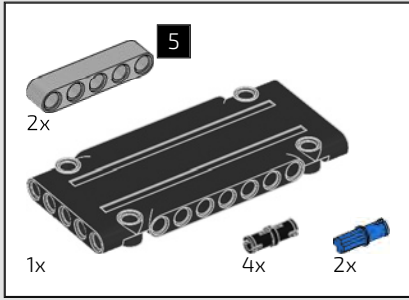

366

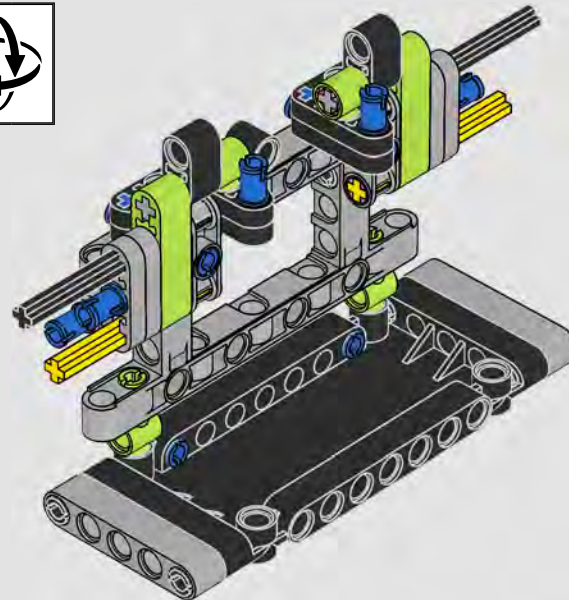
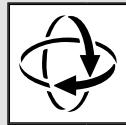
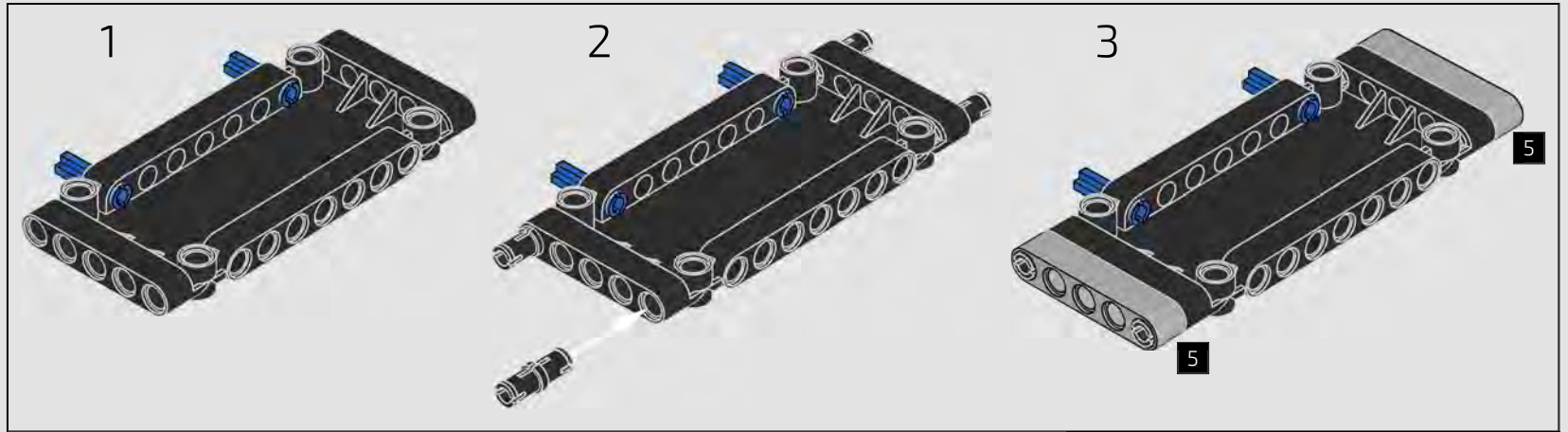

367

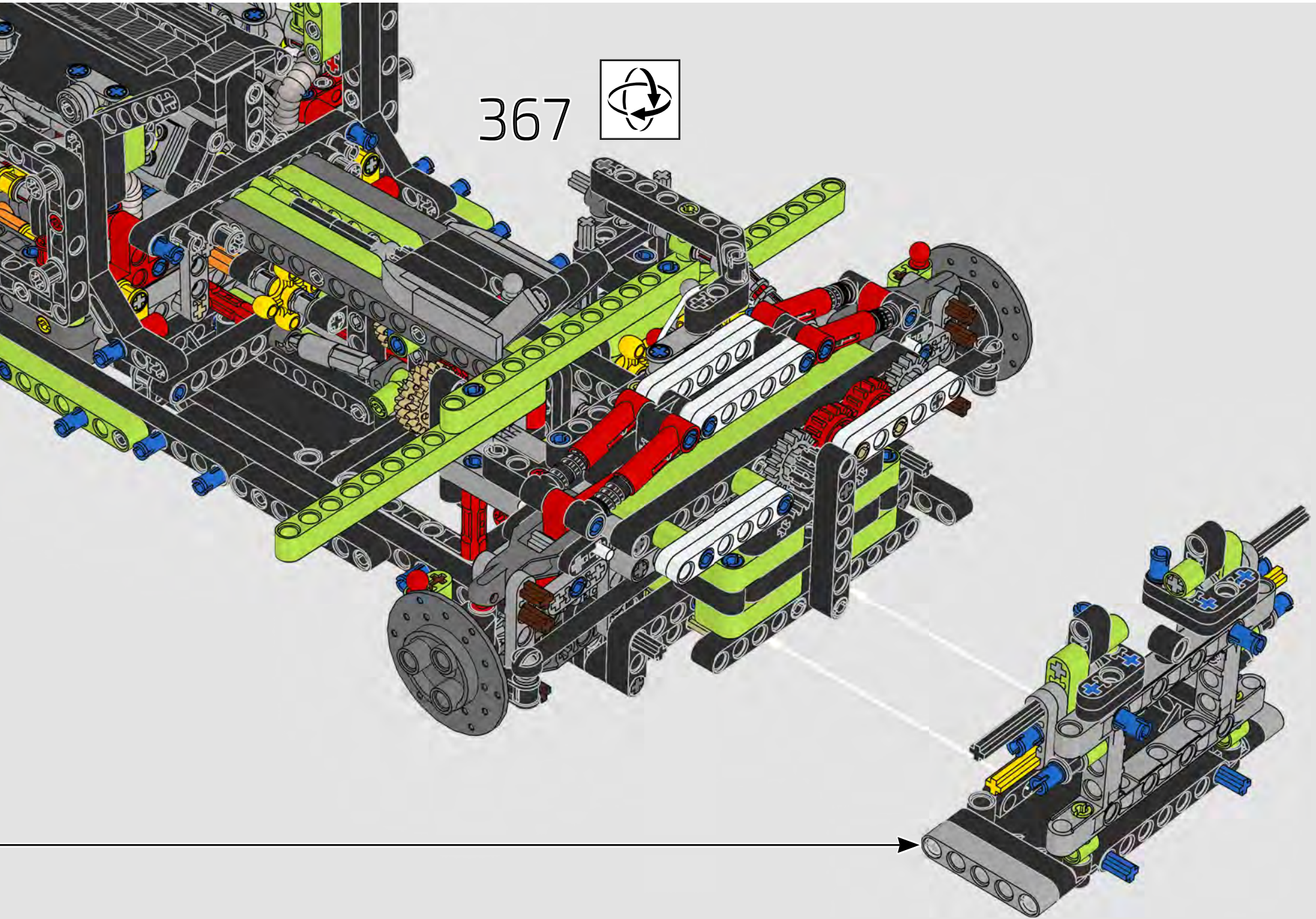

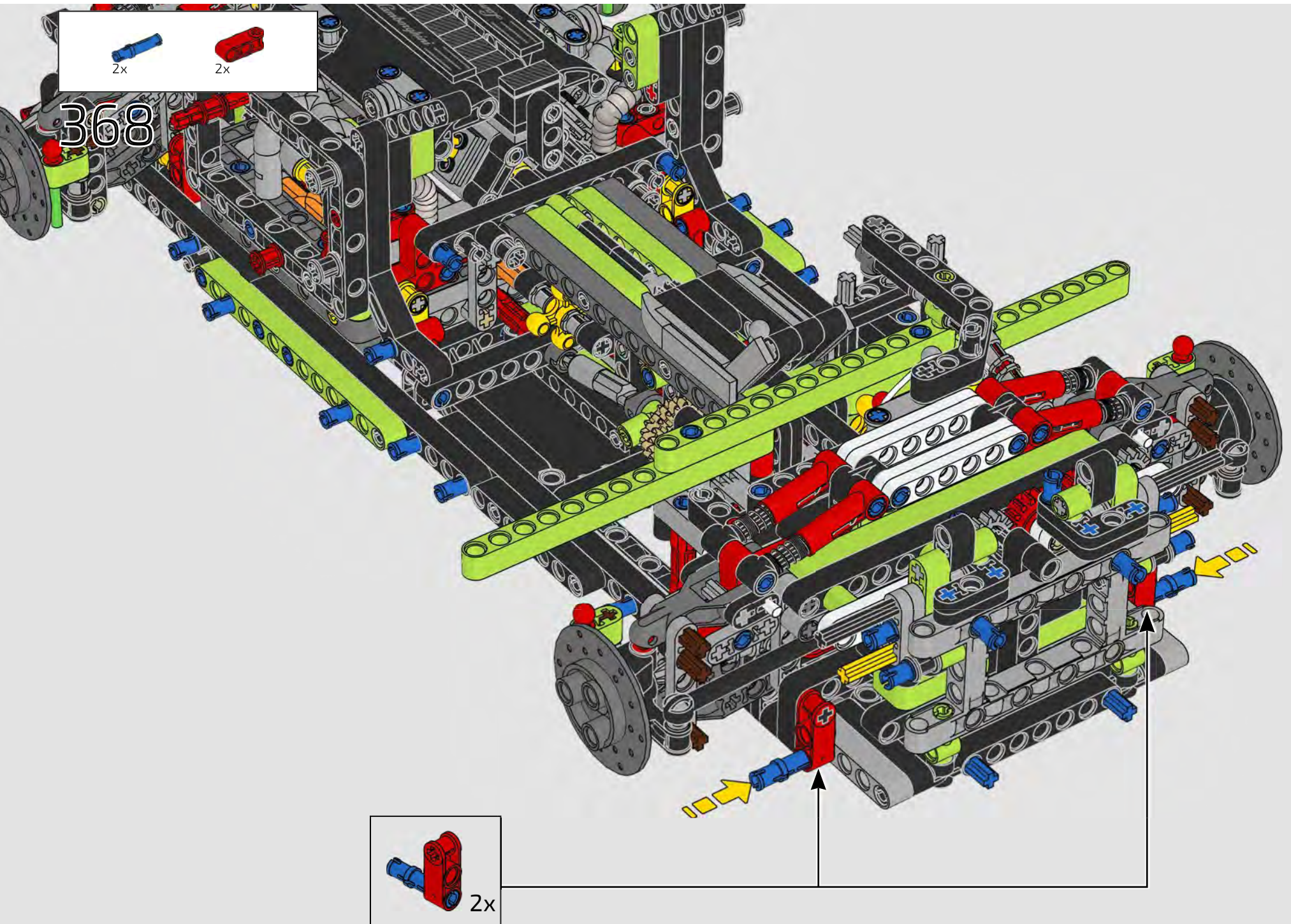



369

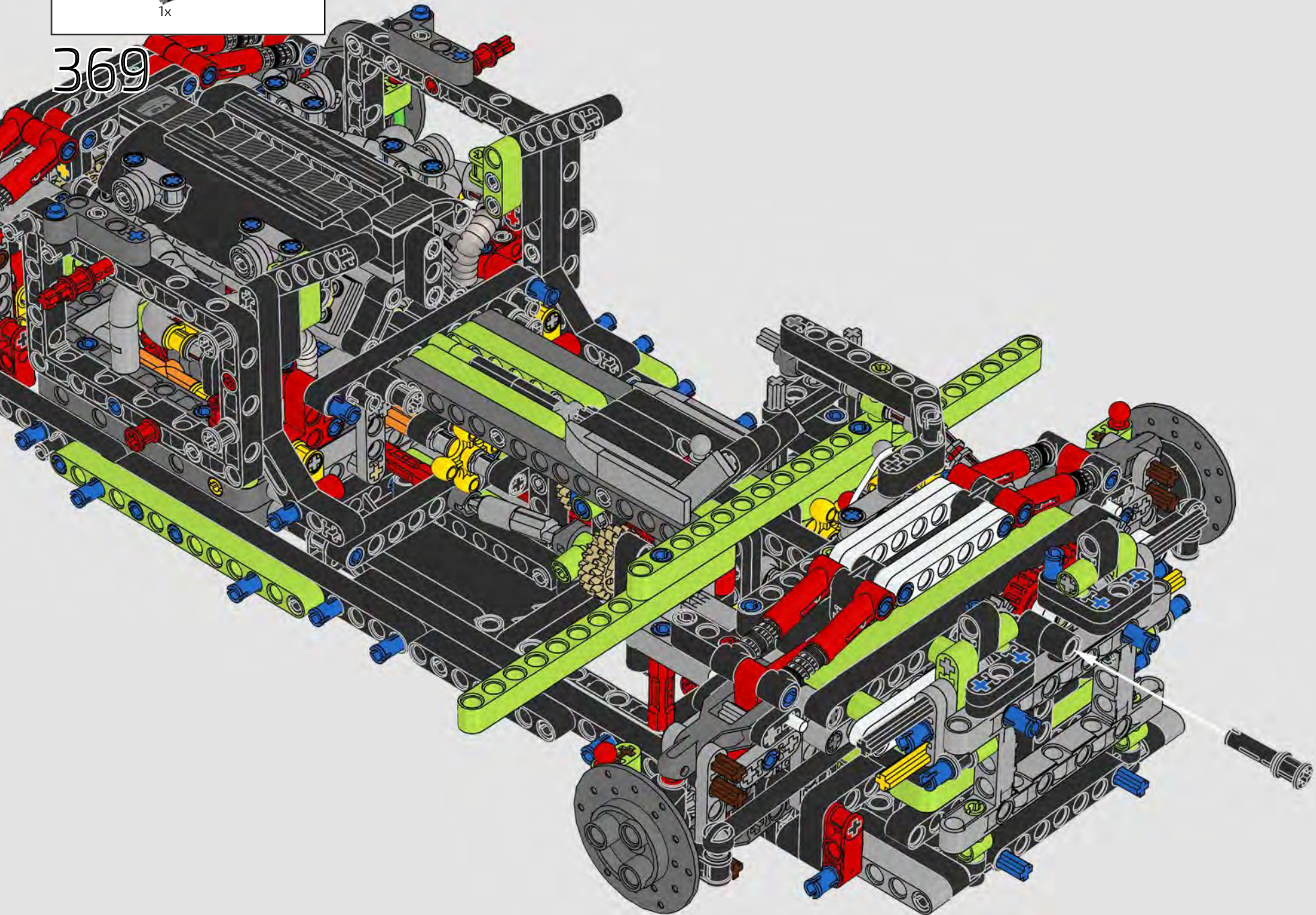

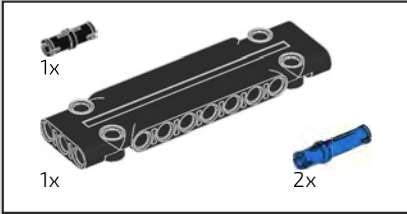
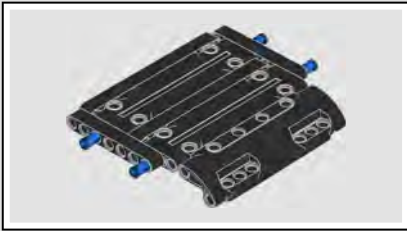

370

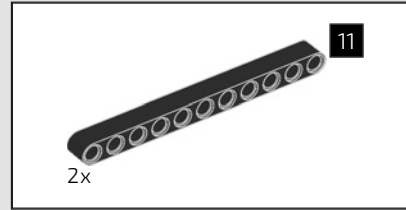

371

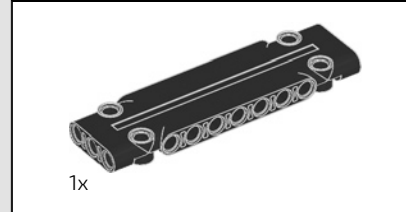
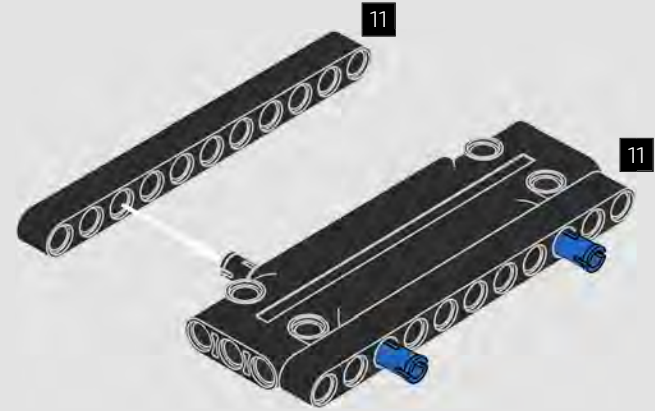

372

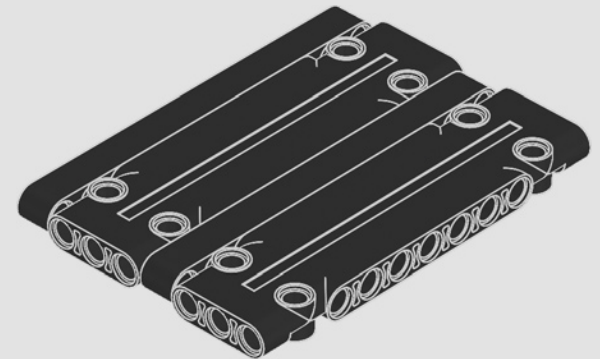

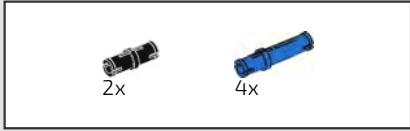

373

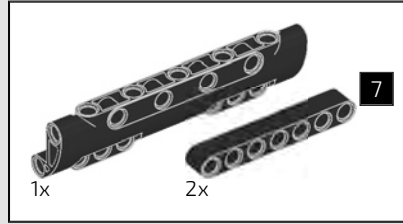
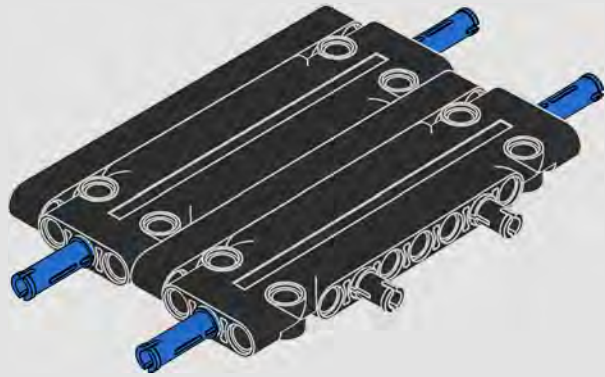

374

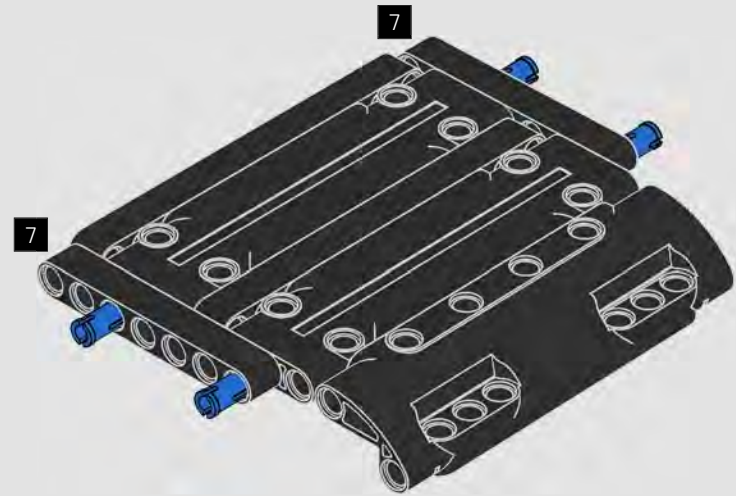
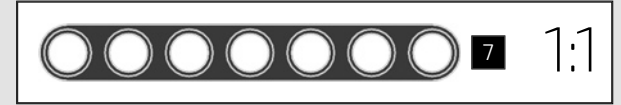

375

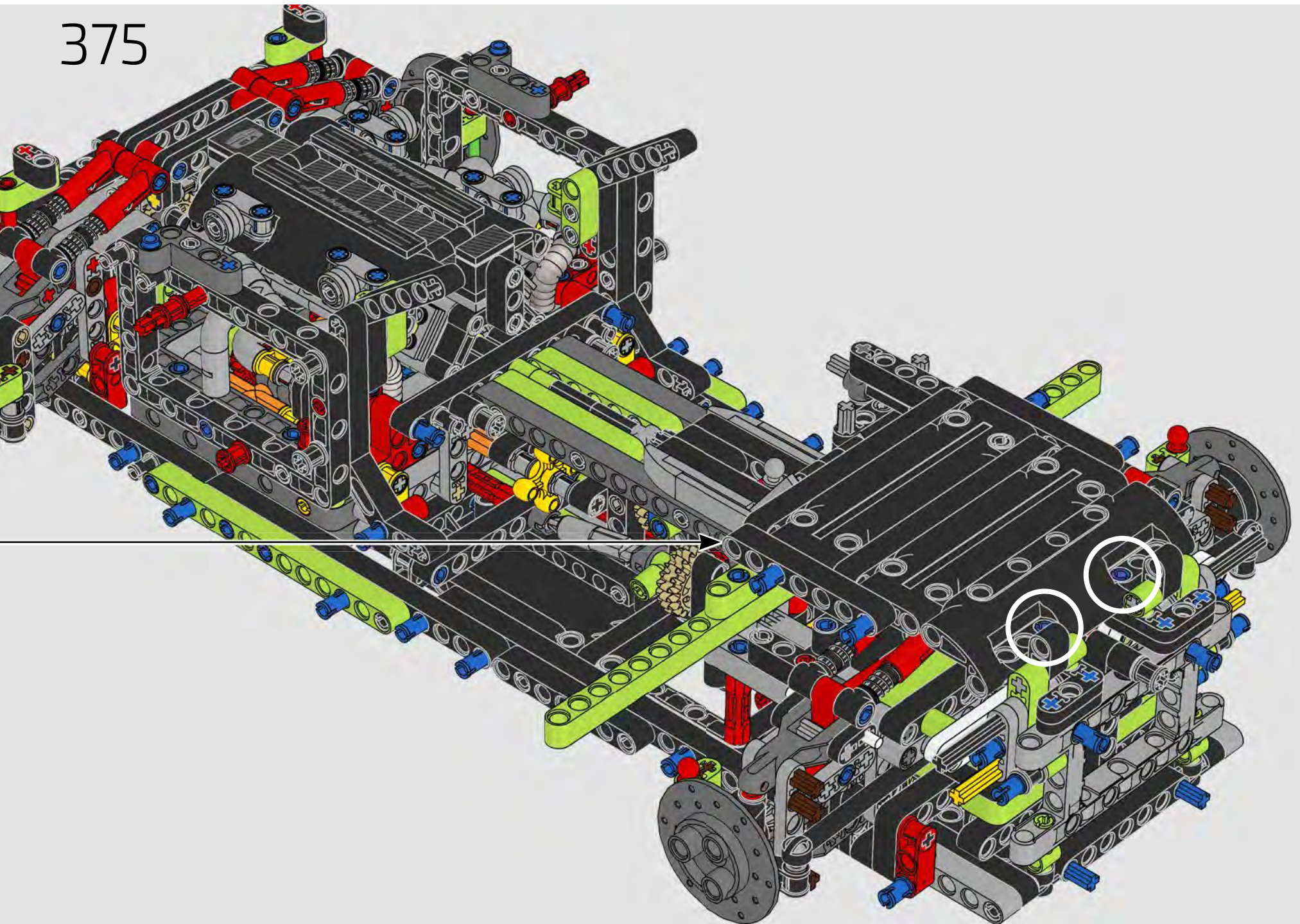



376

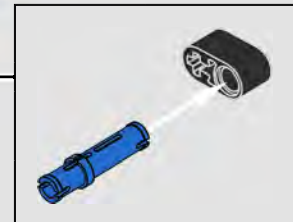
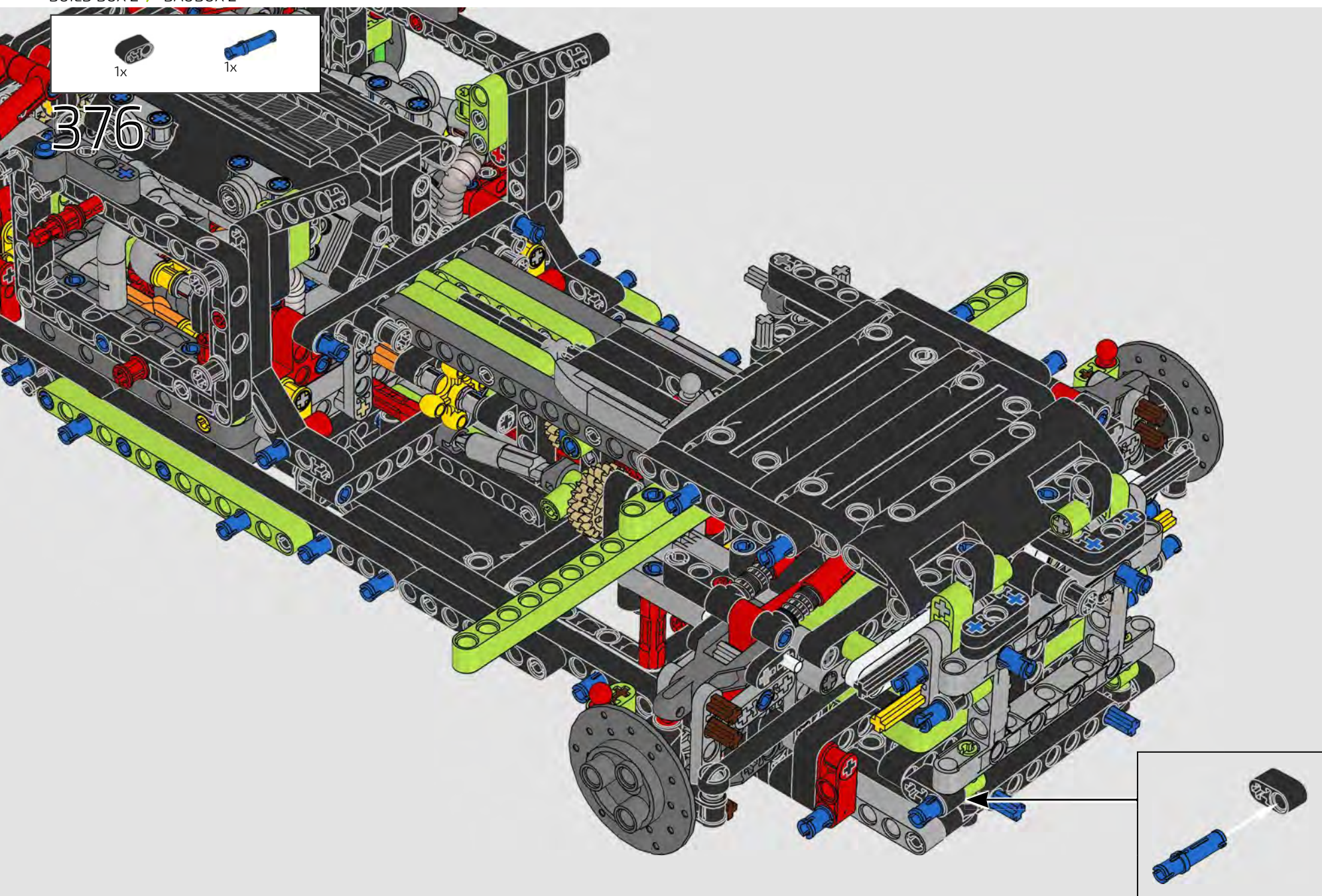

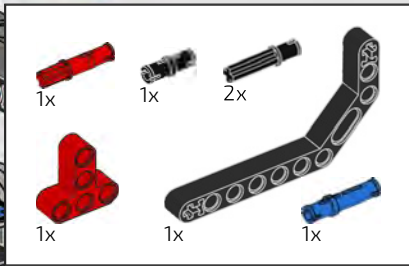

377

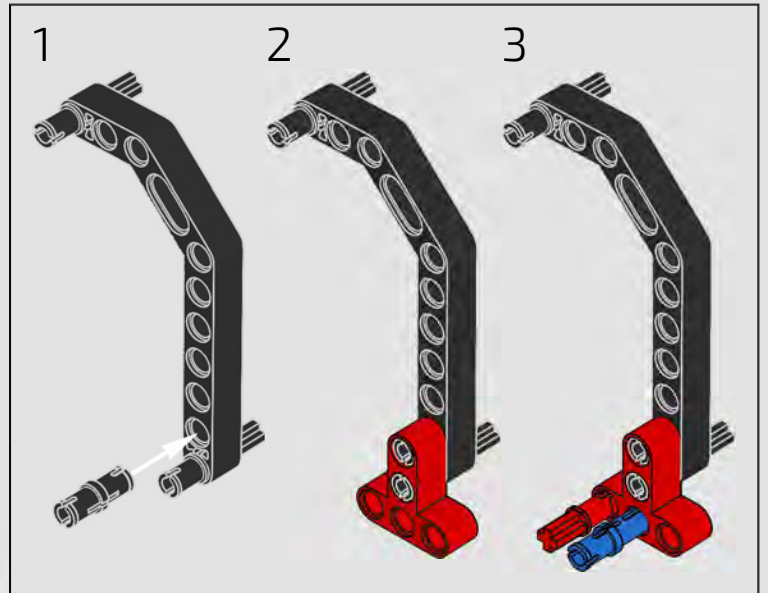
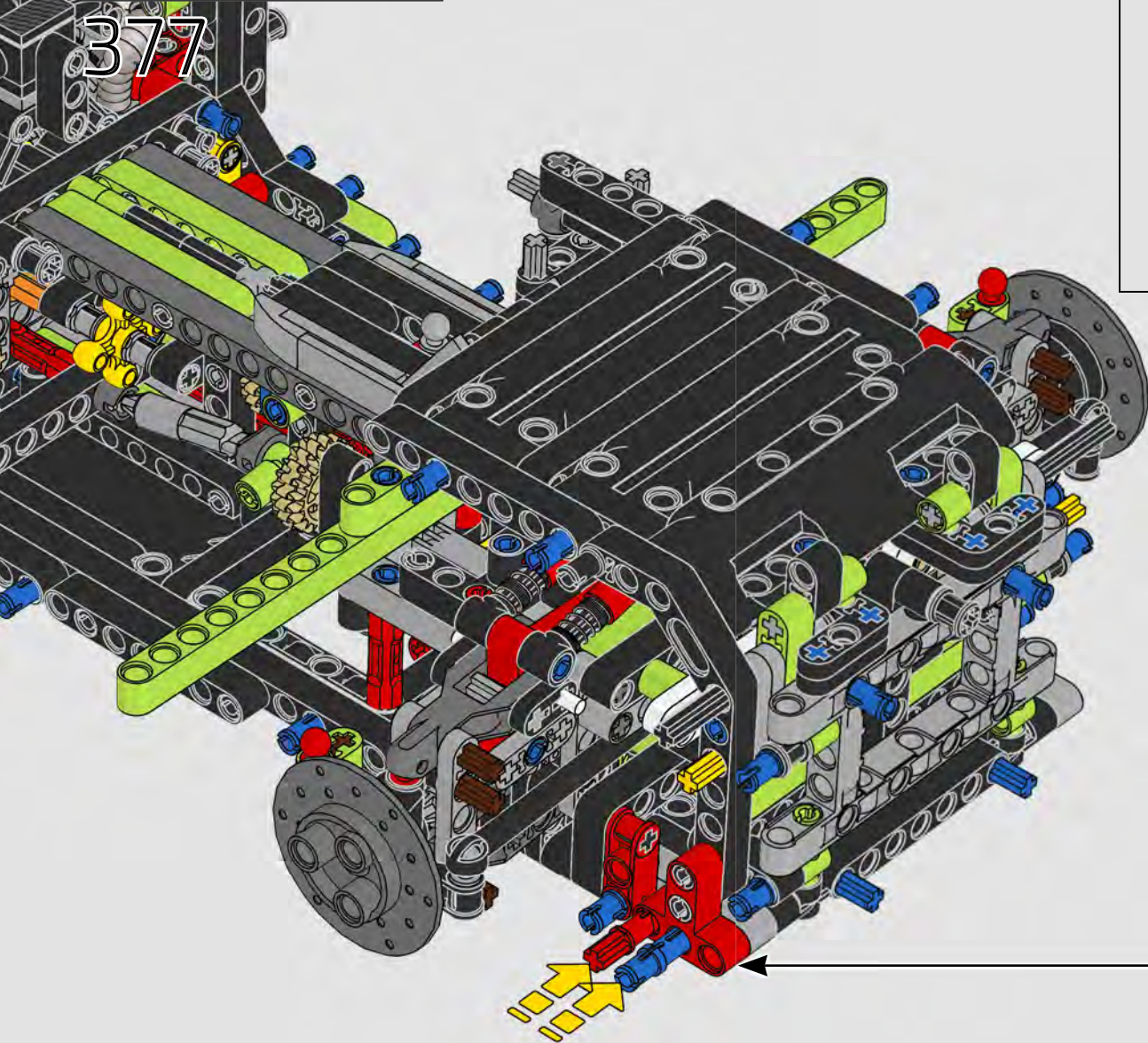

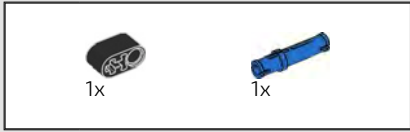

378

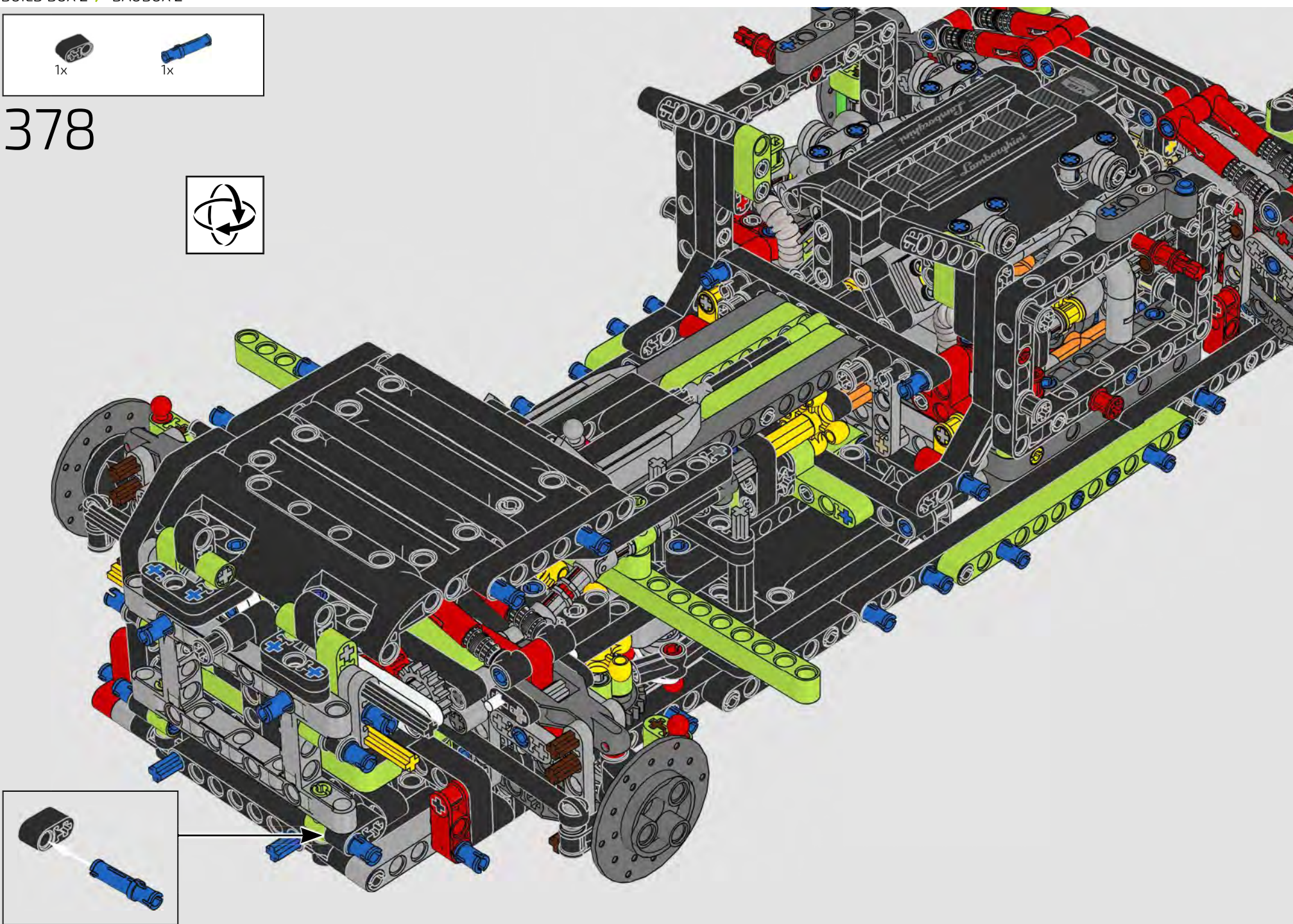

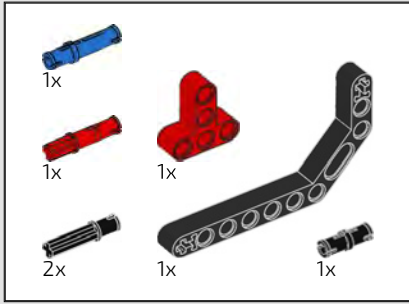

379

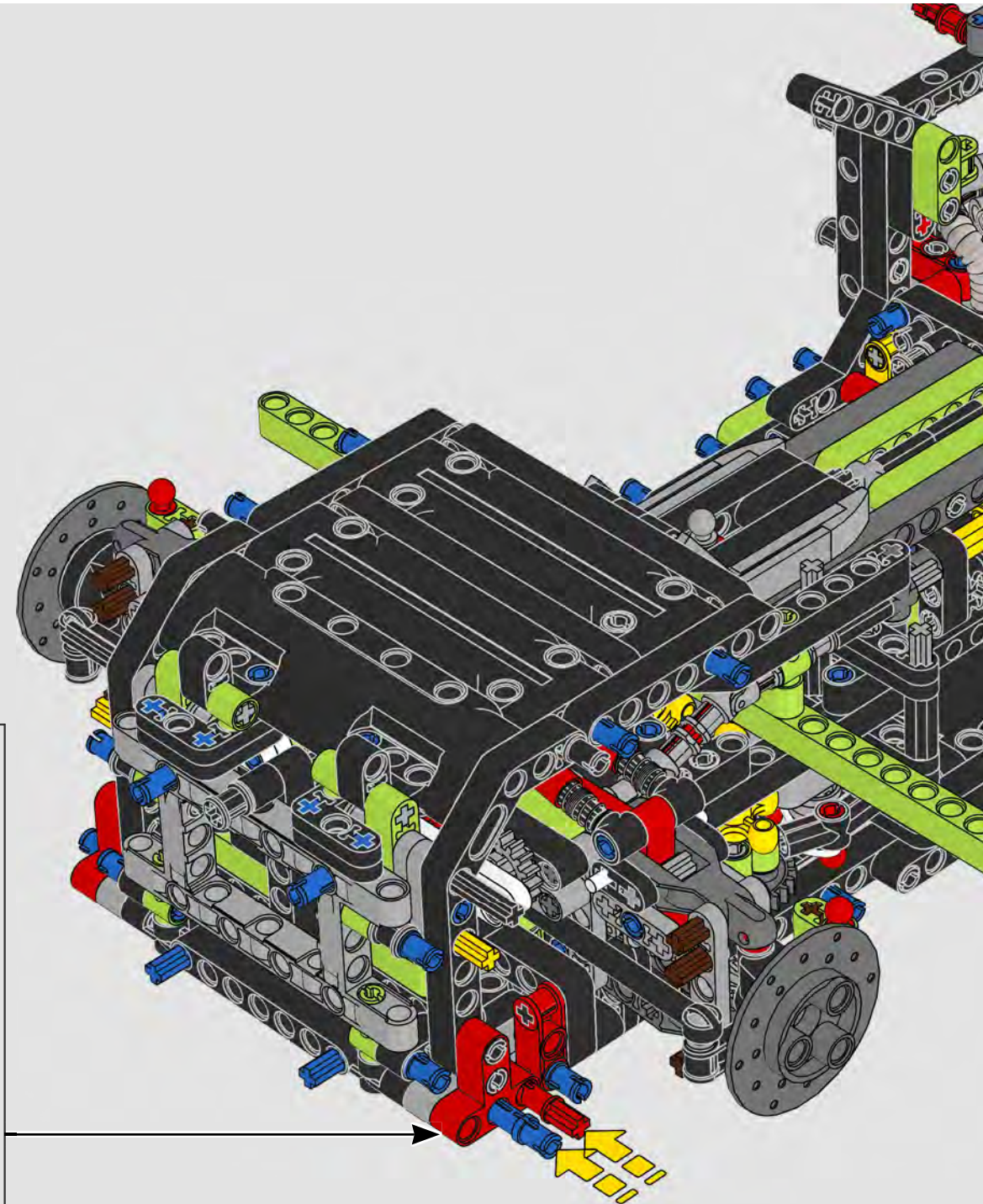
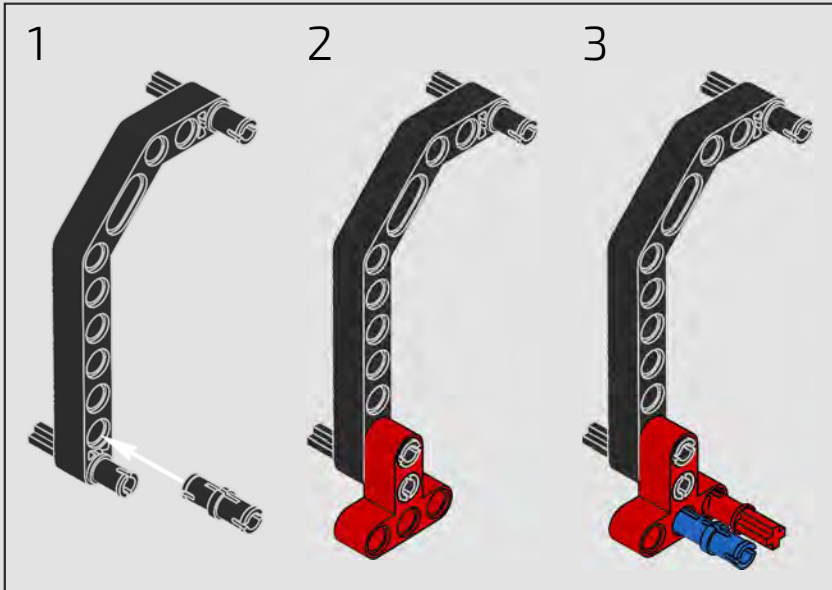

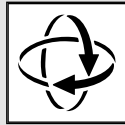
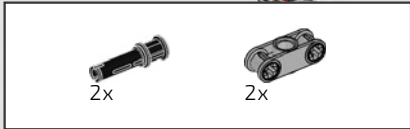

380

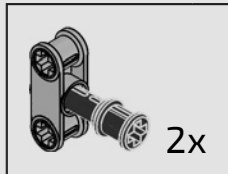
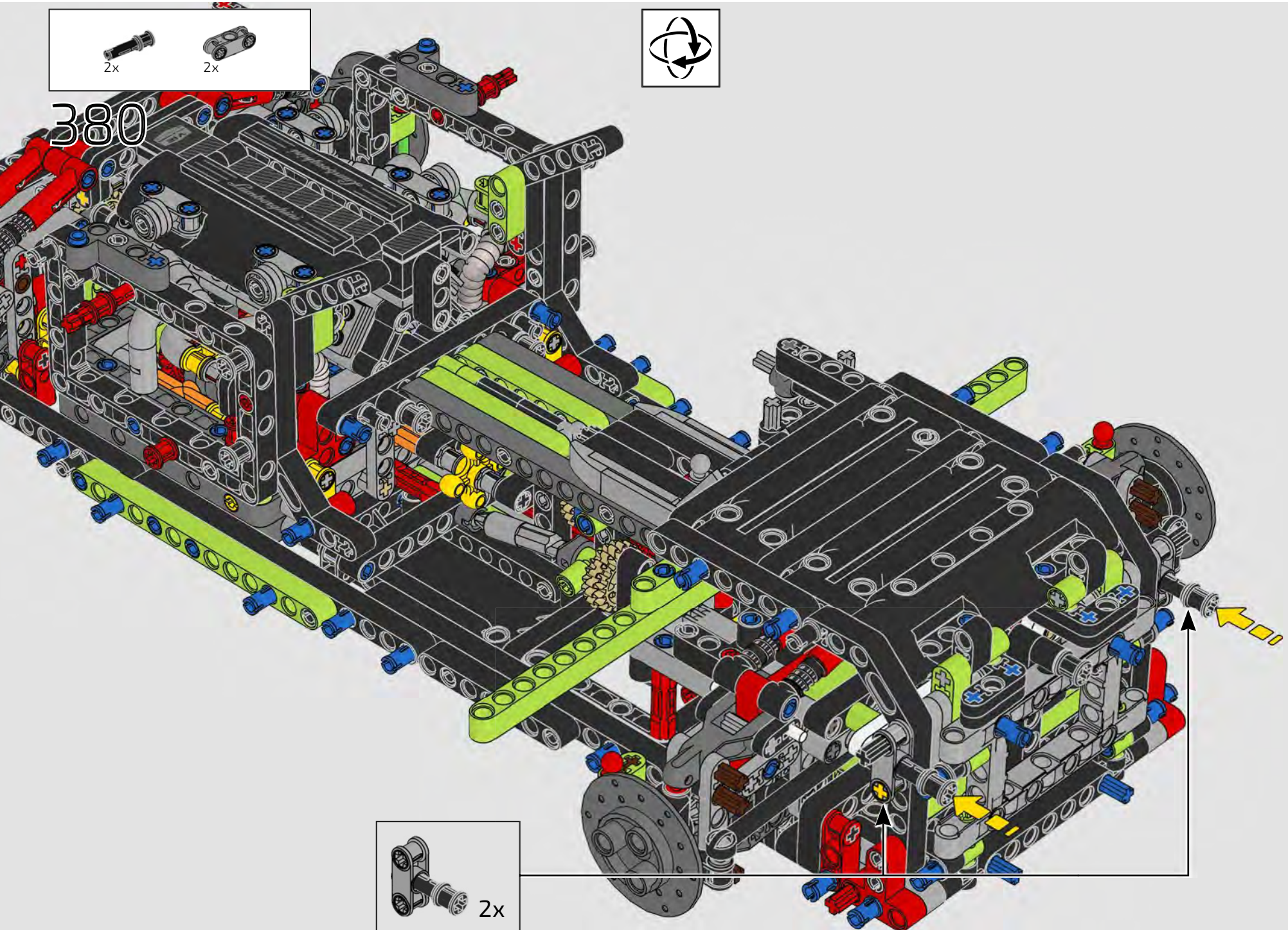

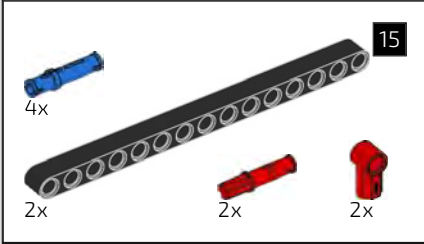
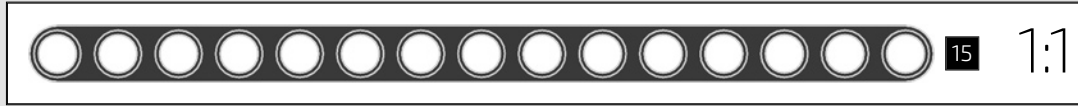
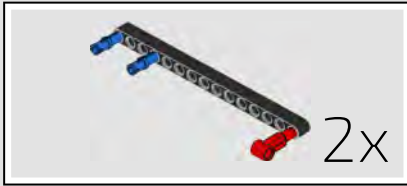

381

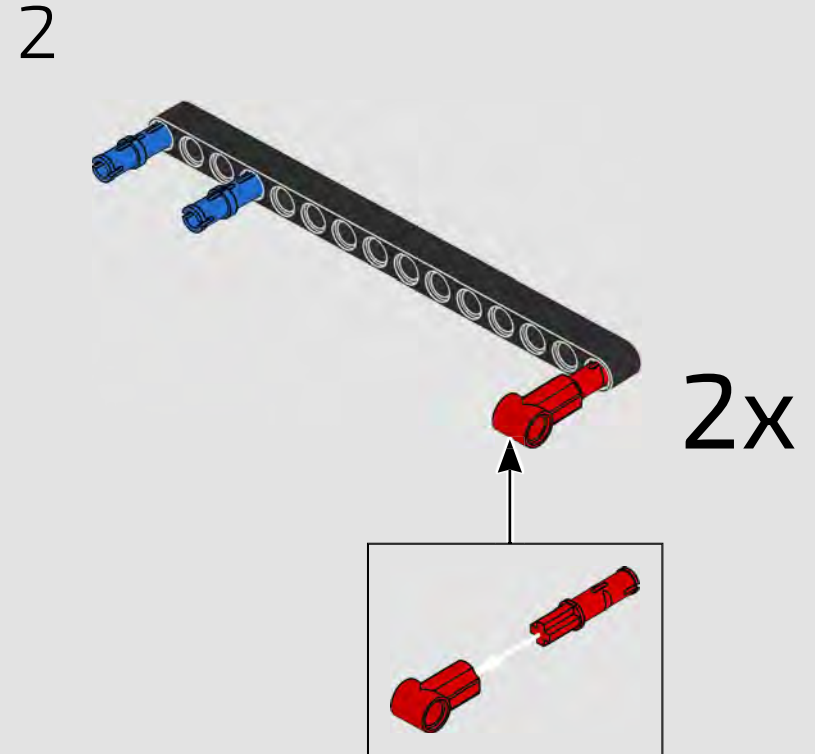
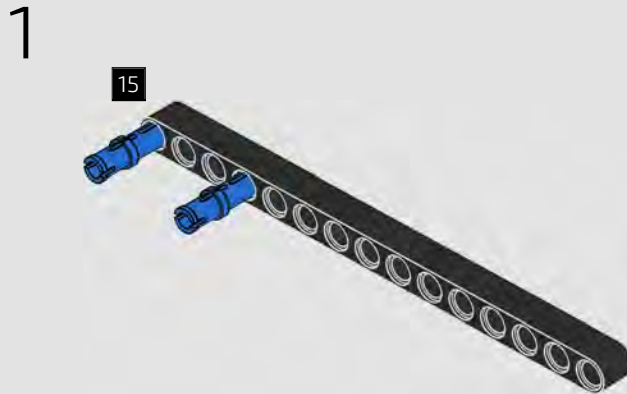

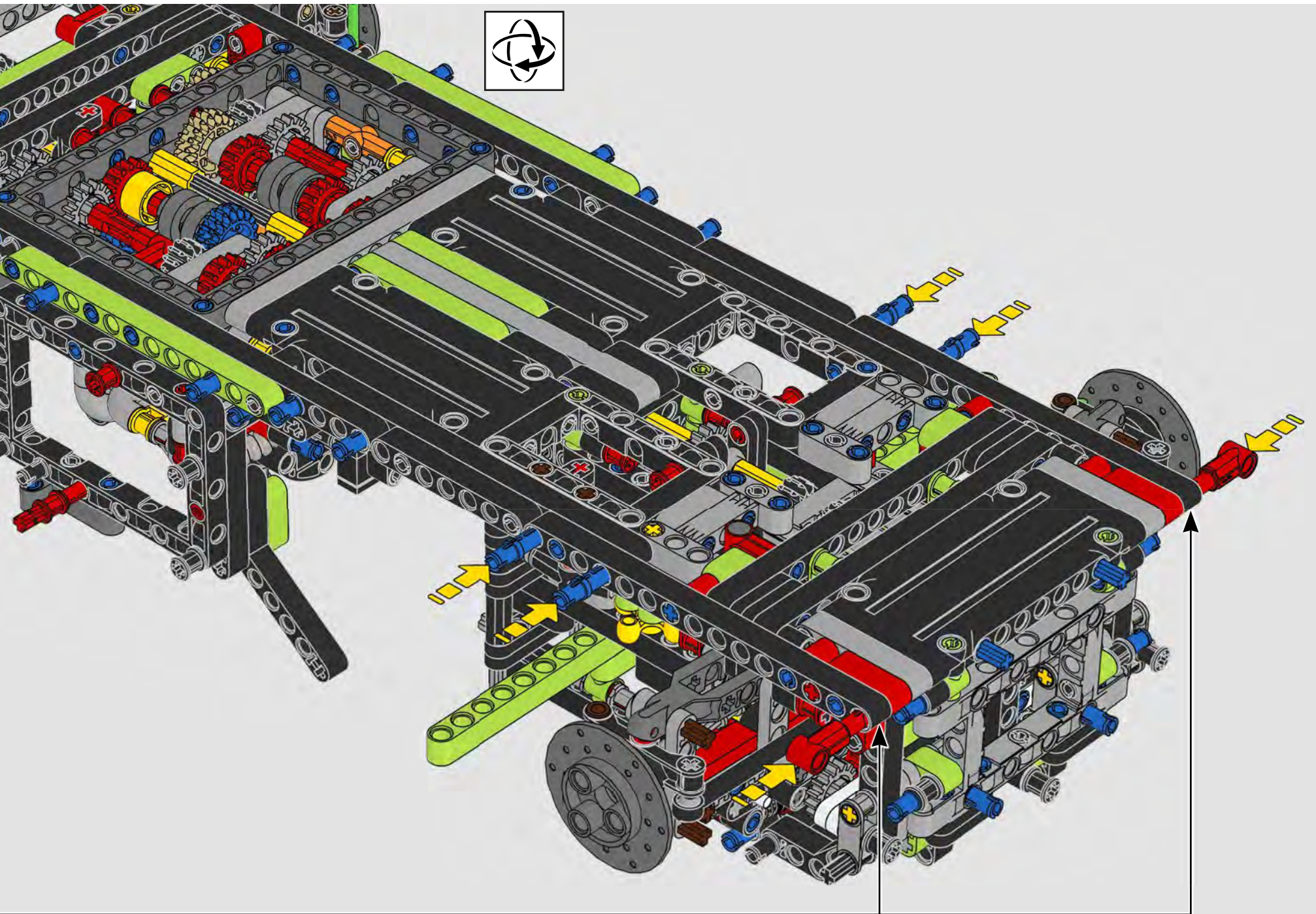

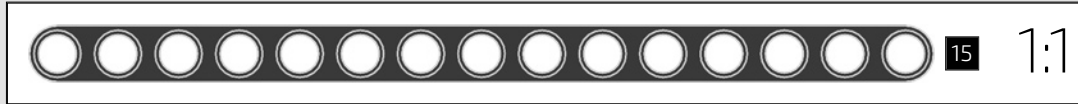
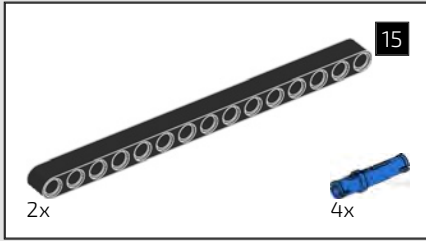

382

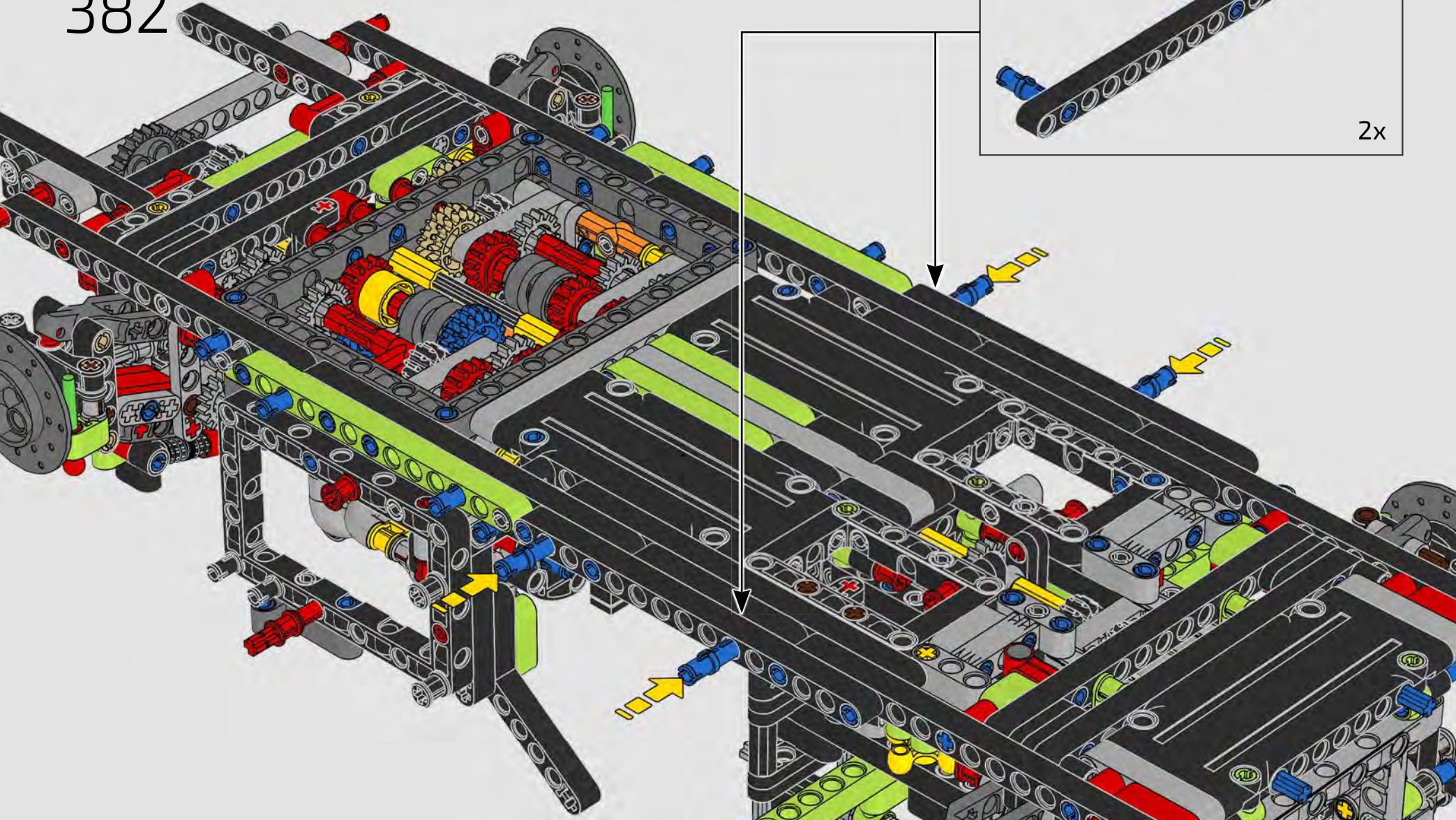

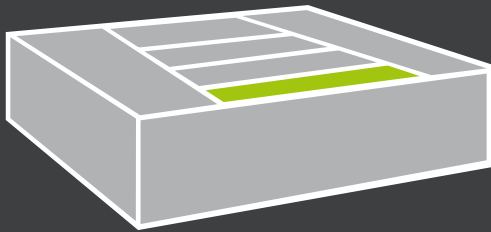

BOX THREE  BOX DREI



INTERIOR DETAILS & SEATS

INNENAUSSTATTUNG & SITZE

LEGO® Technic designers take pride in trying to create models using as many existing Technic elements as possible. But to truly capture the dramatic curves of the Sián FKP 37, the team needed to create a few new elements. Listen as Design Master Markus Kossmann explains the process.

LEGO® Technic Designer legen höchsten Wert darauf, für neue Modelle möglichst viele bereits vorhandene Technic Elemente zu verwenden. Doch um die spektakulären Kurven des Sián FKP 37 originalgetreu nachzubilden, musste das Team einige ganz neue Elemente erschaffen. Hören Sie sich an, wie Design Master Markus Kossmann diesen Prozess beschreibt.



> www.LEGO.com/lamborghini-sian/videocasts



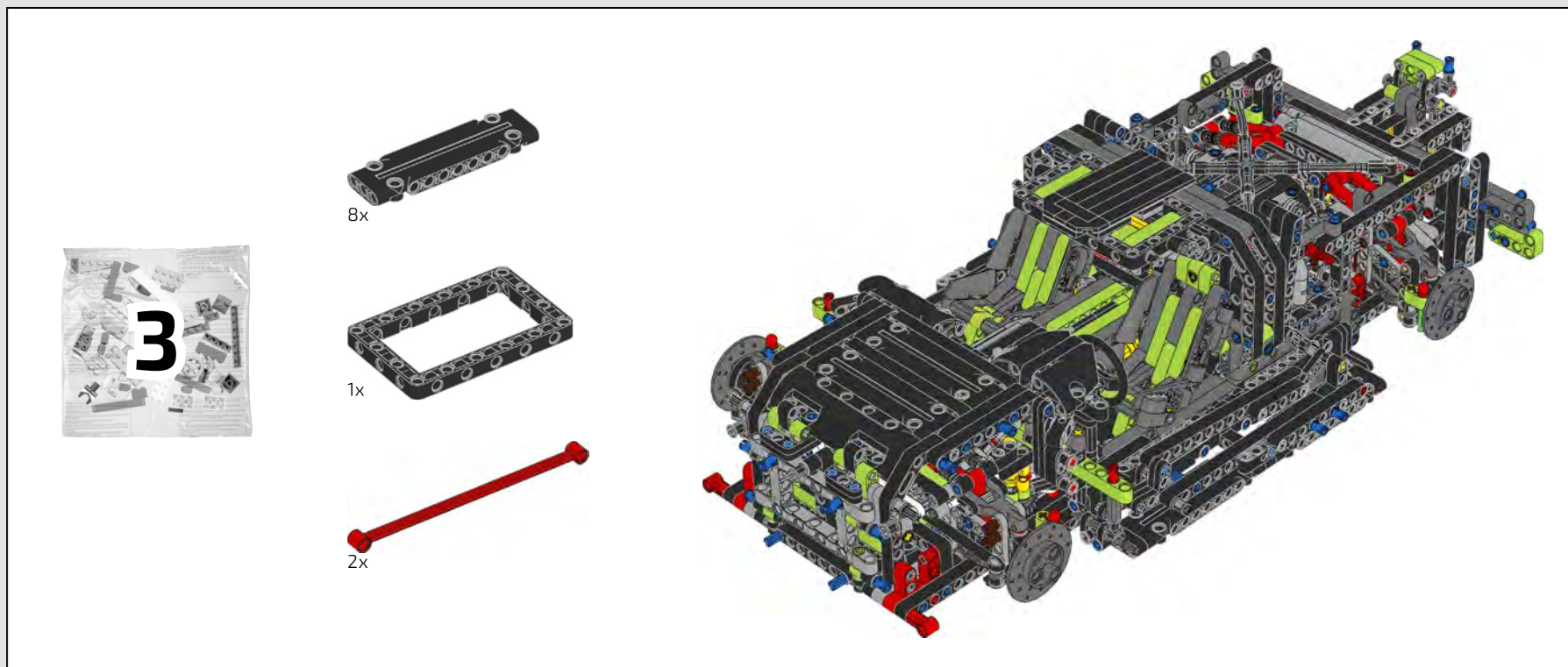

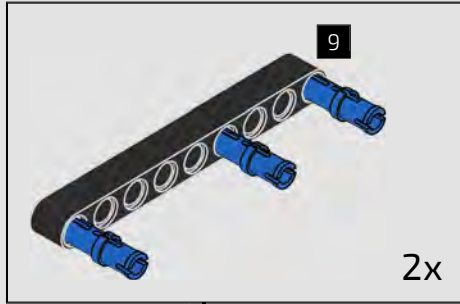
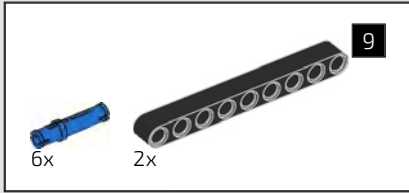

383

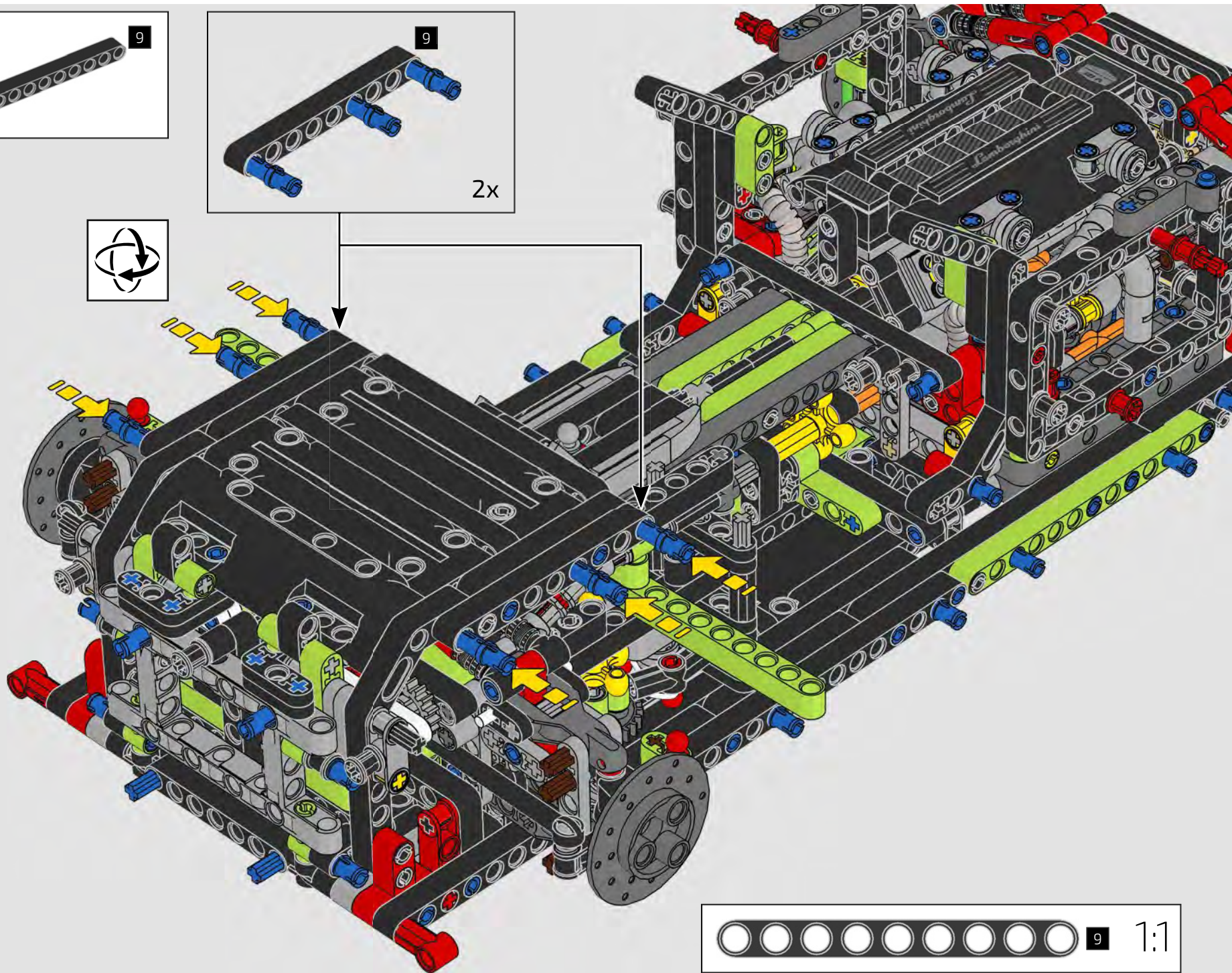
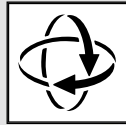

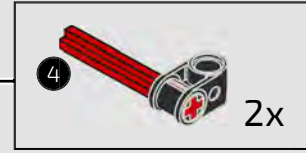
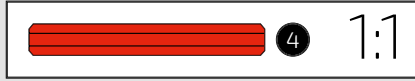
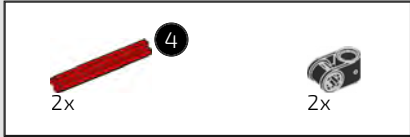

384

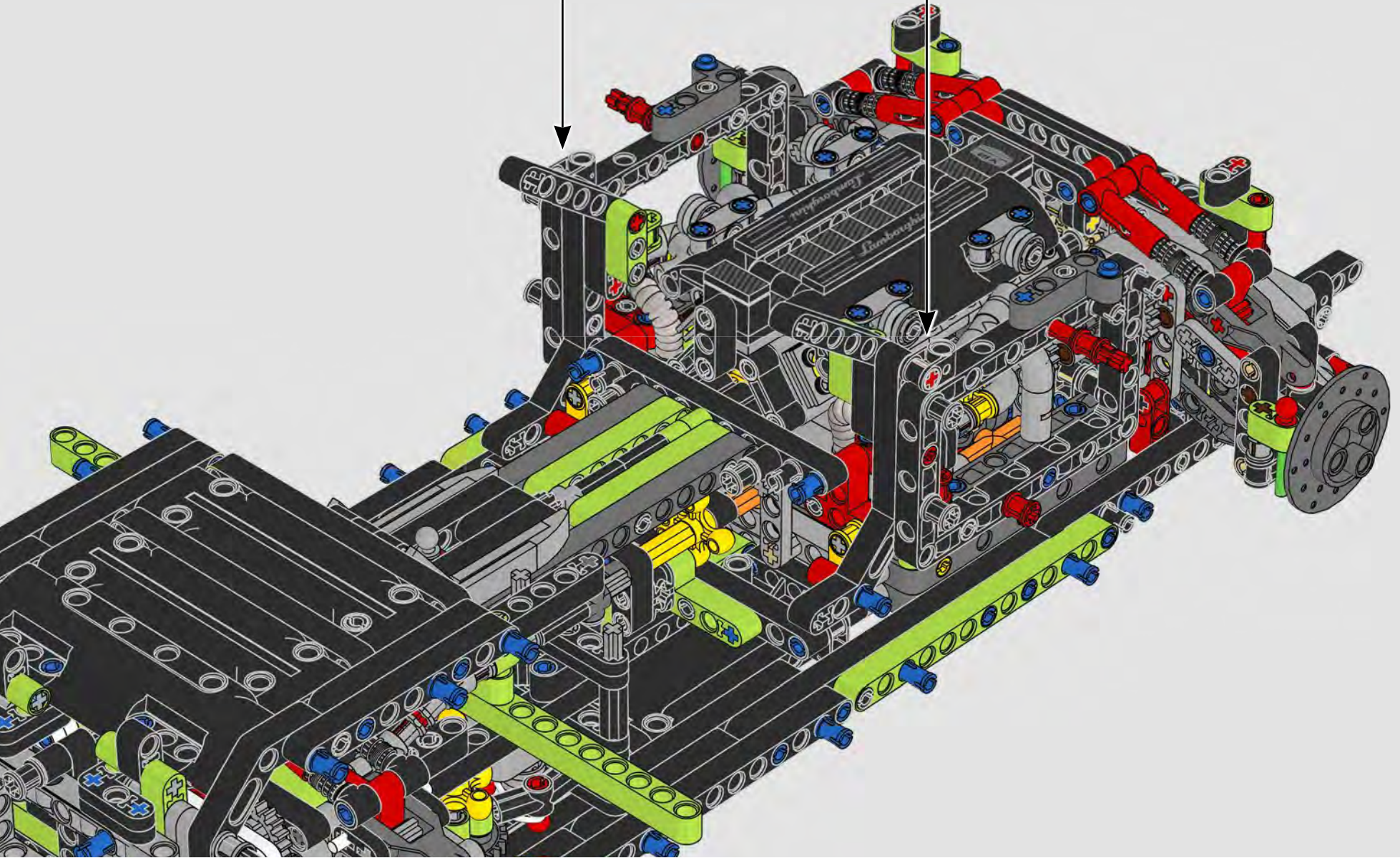

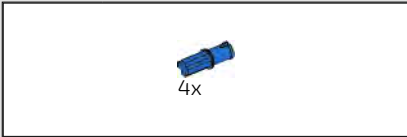

385

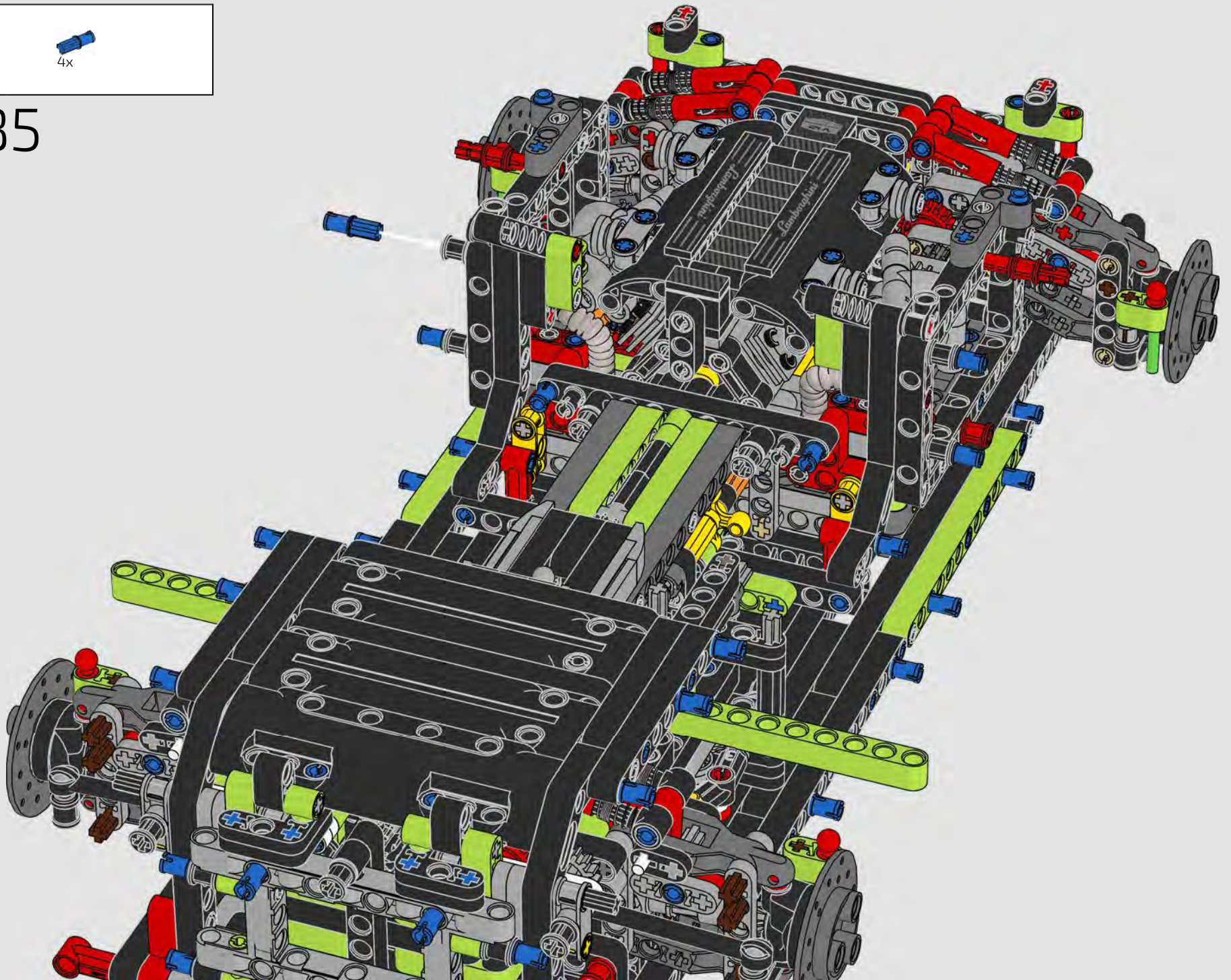

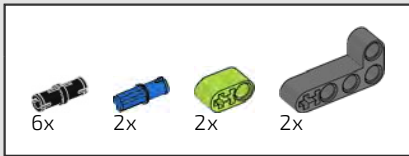

386

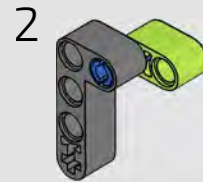
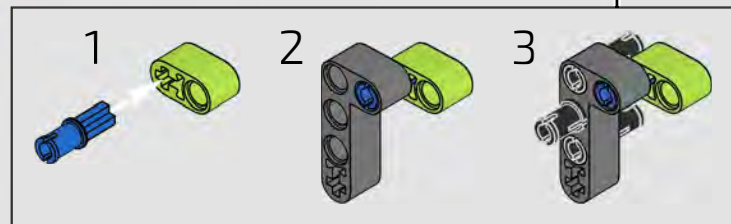
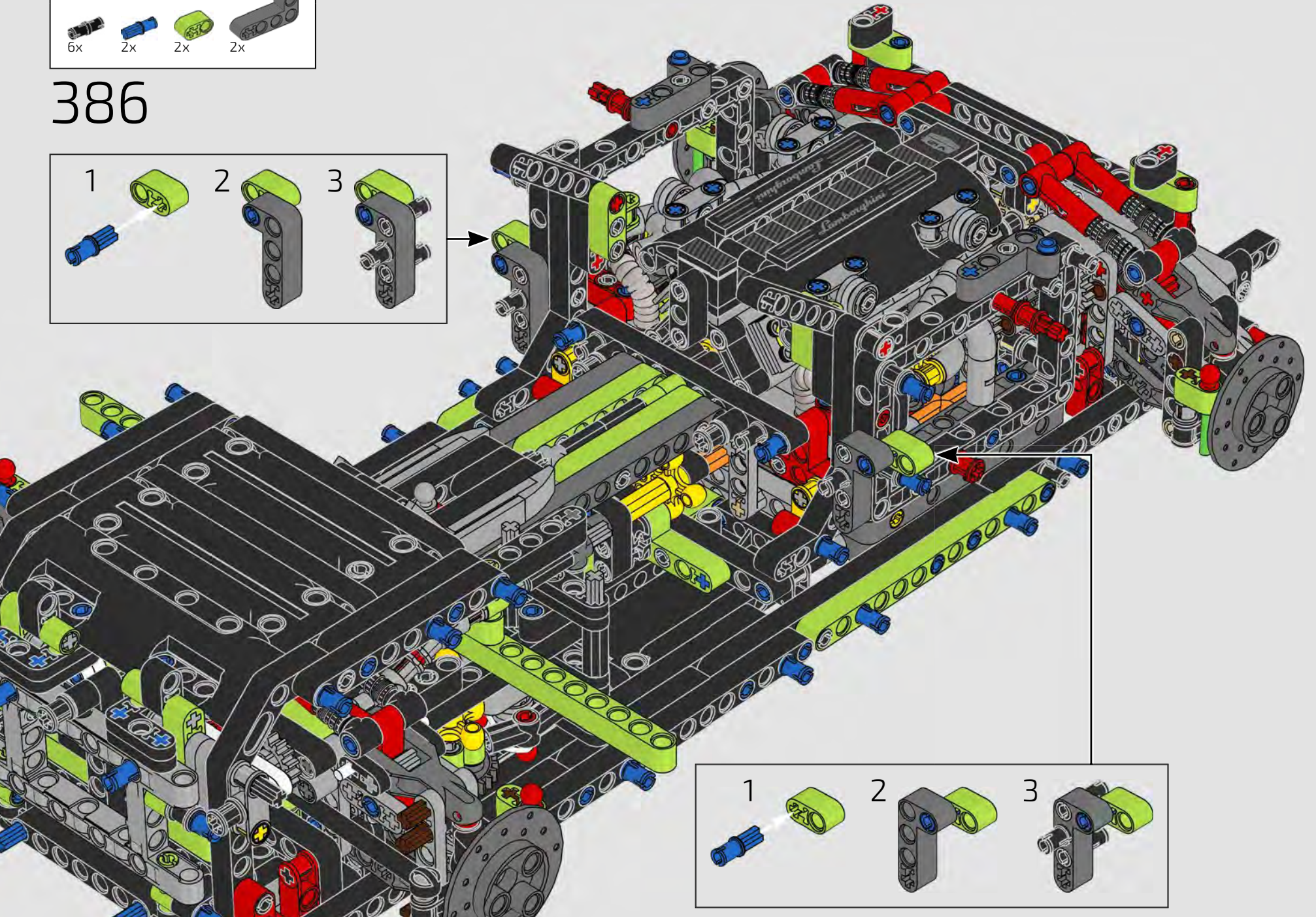
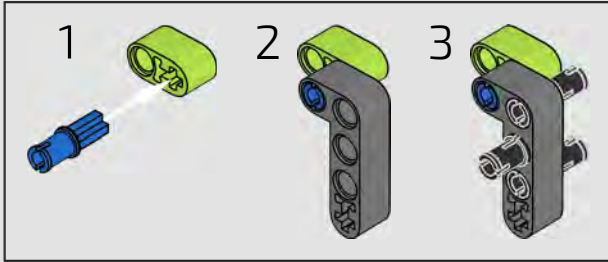

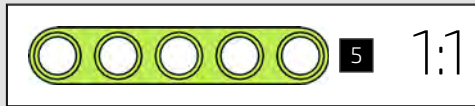
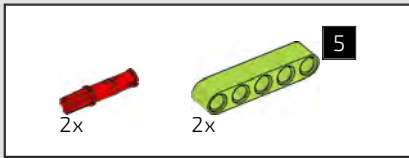

387

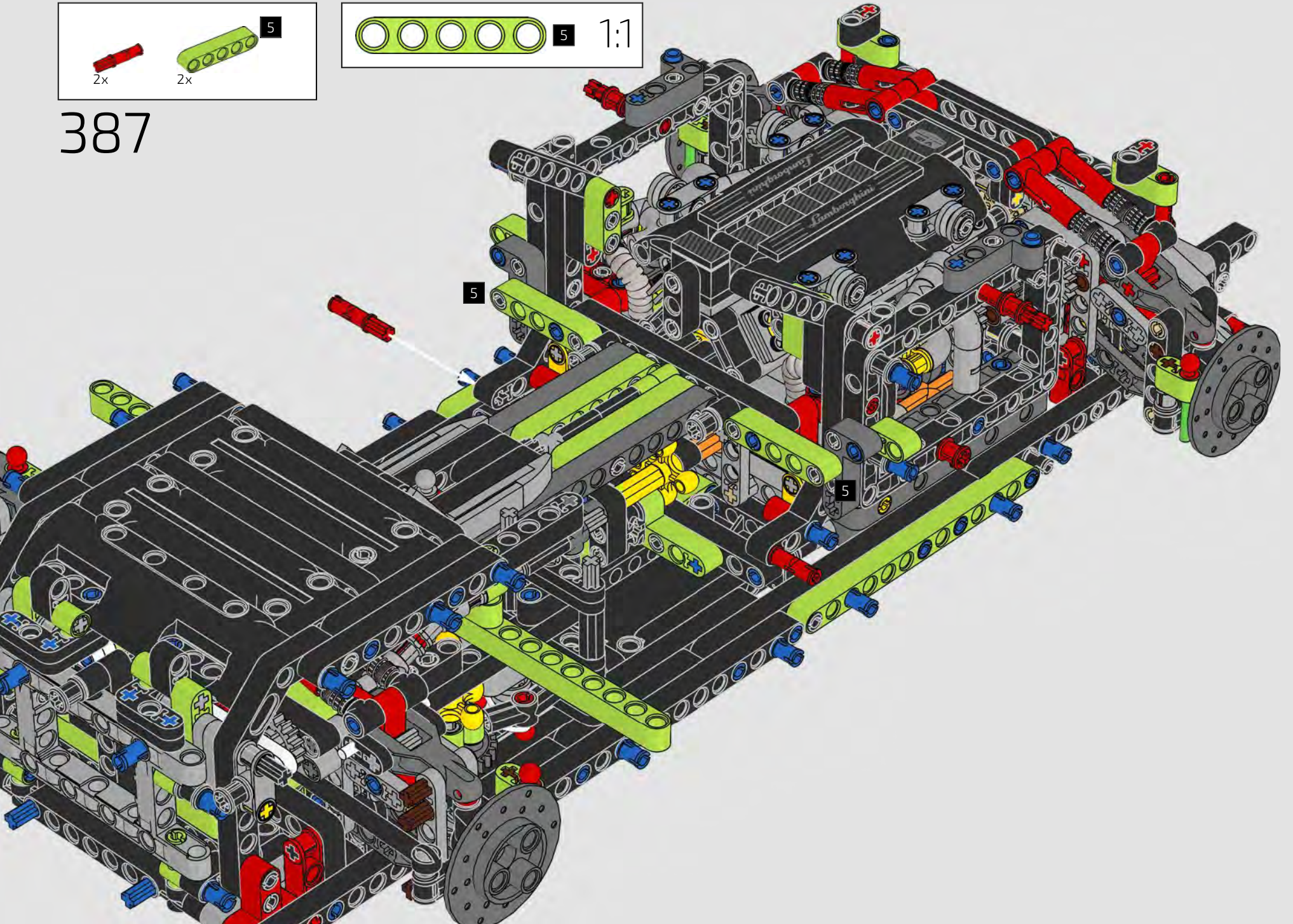

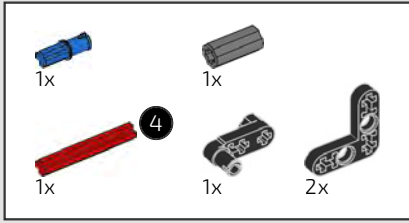

388

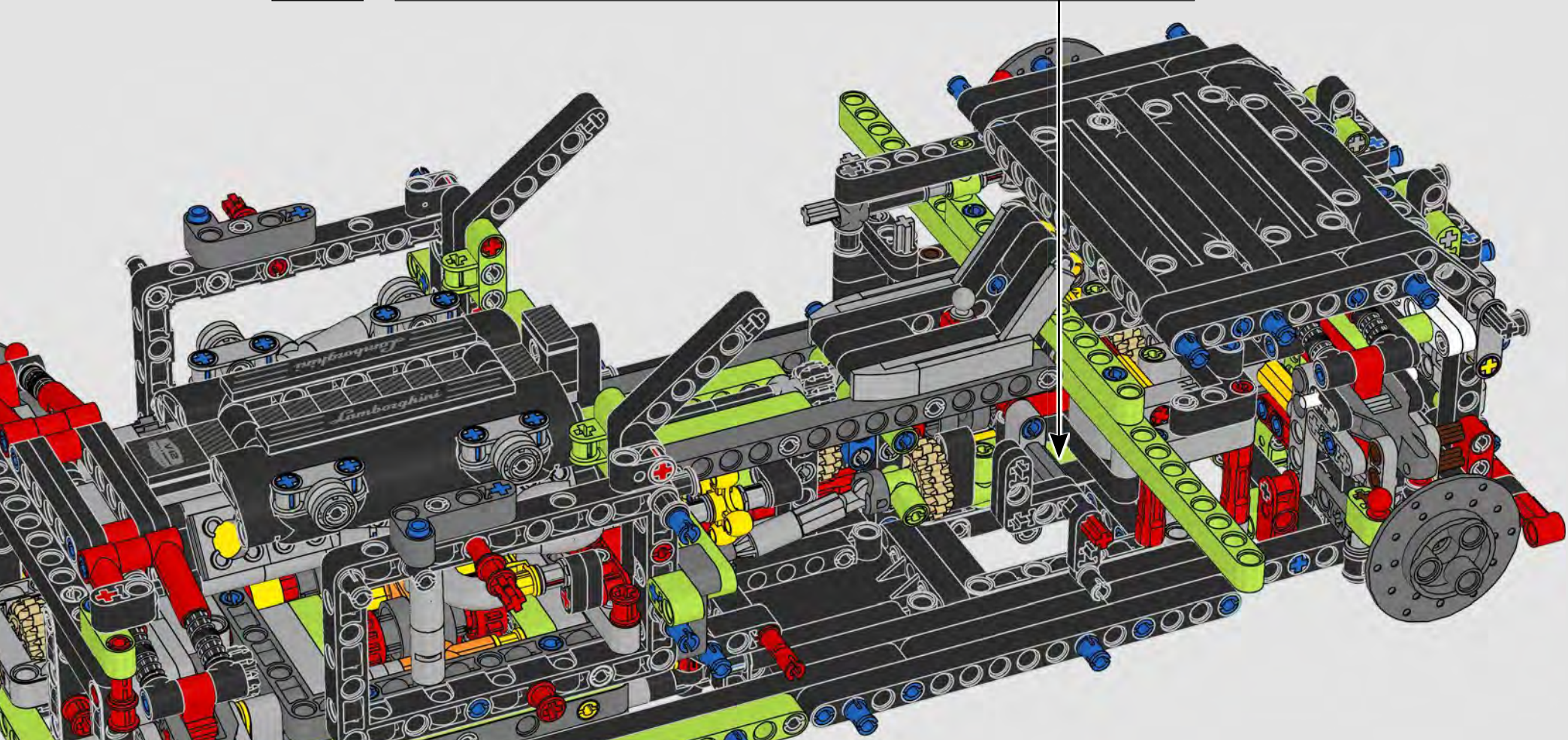
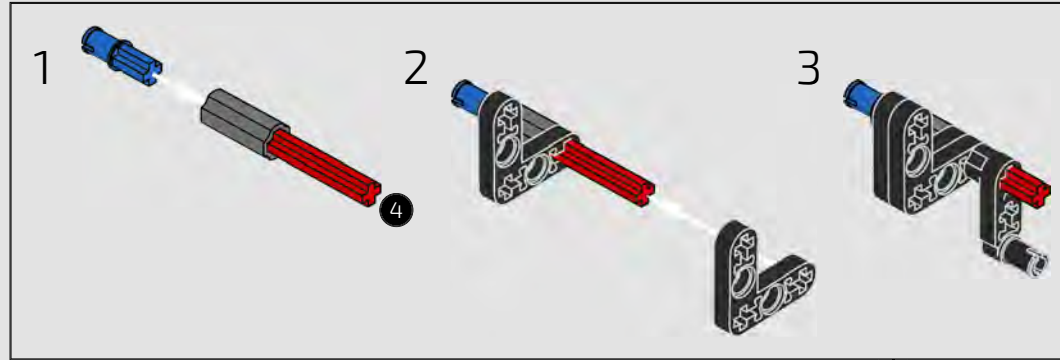
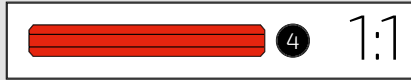

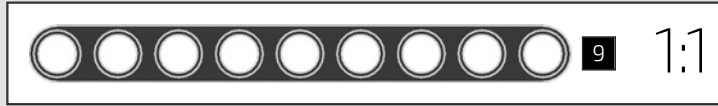
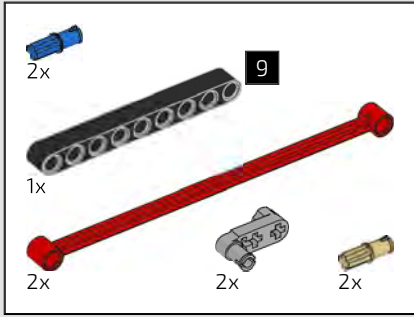

389

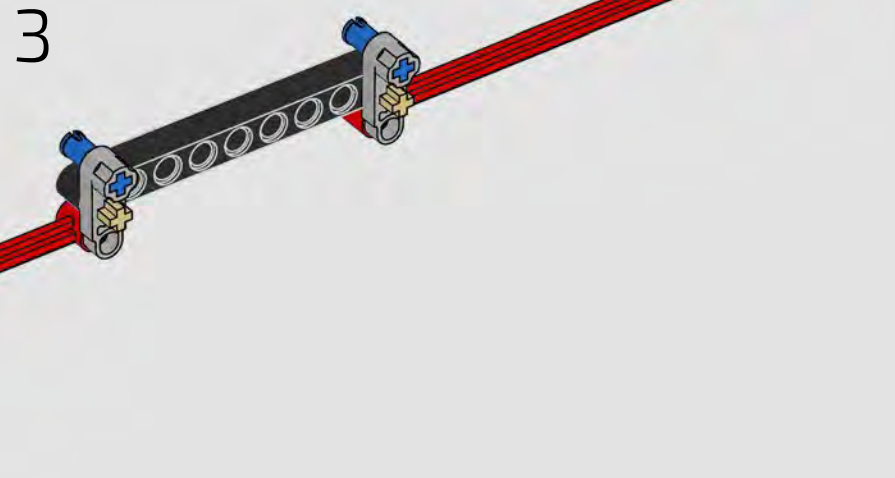
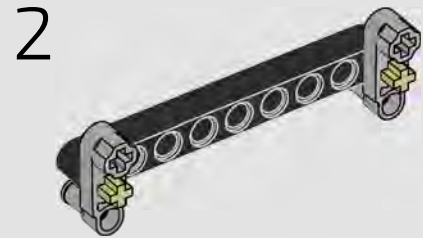

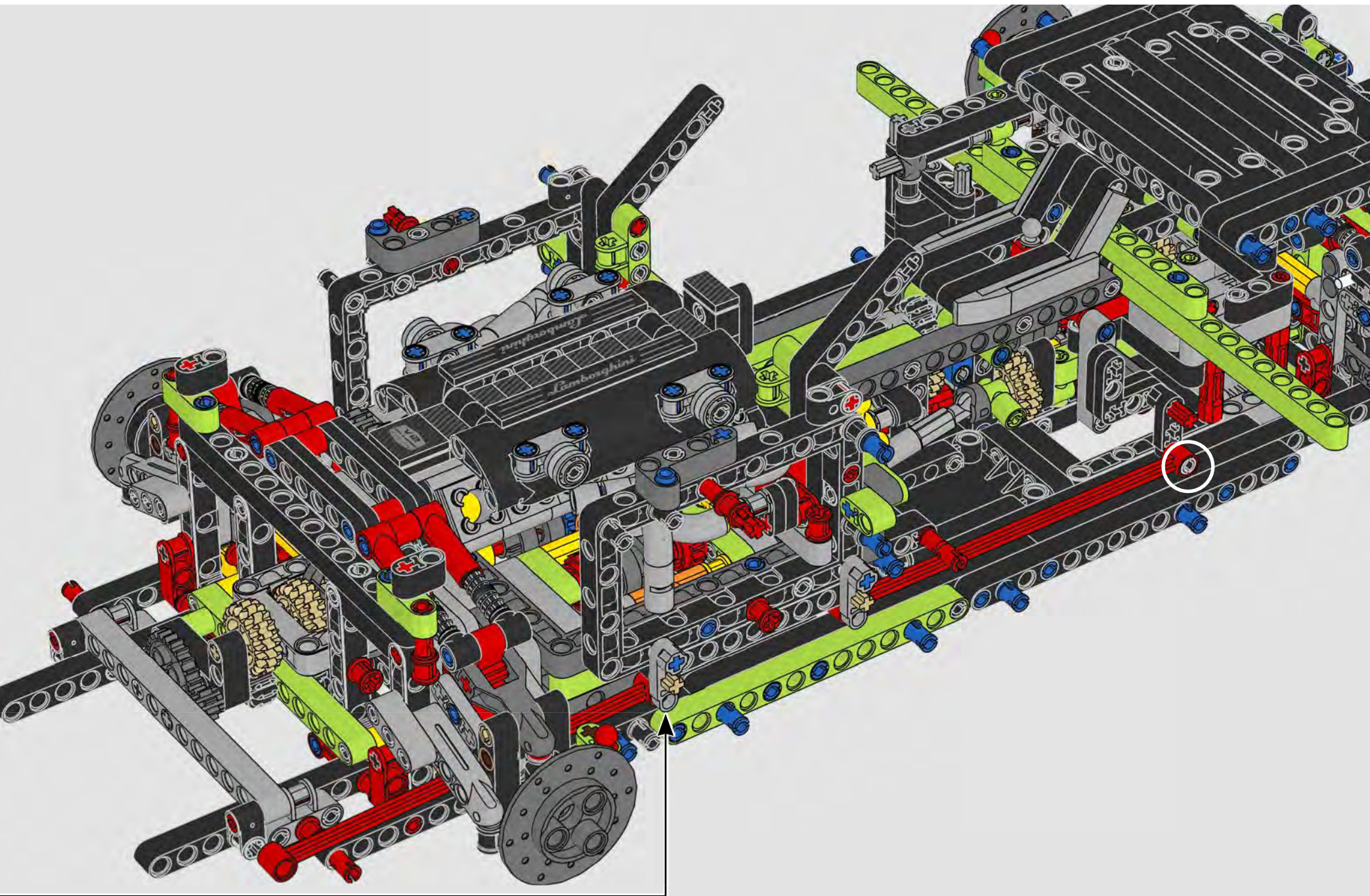

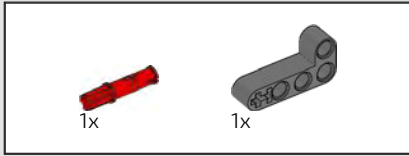

390

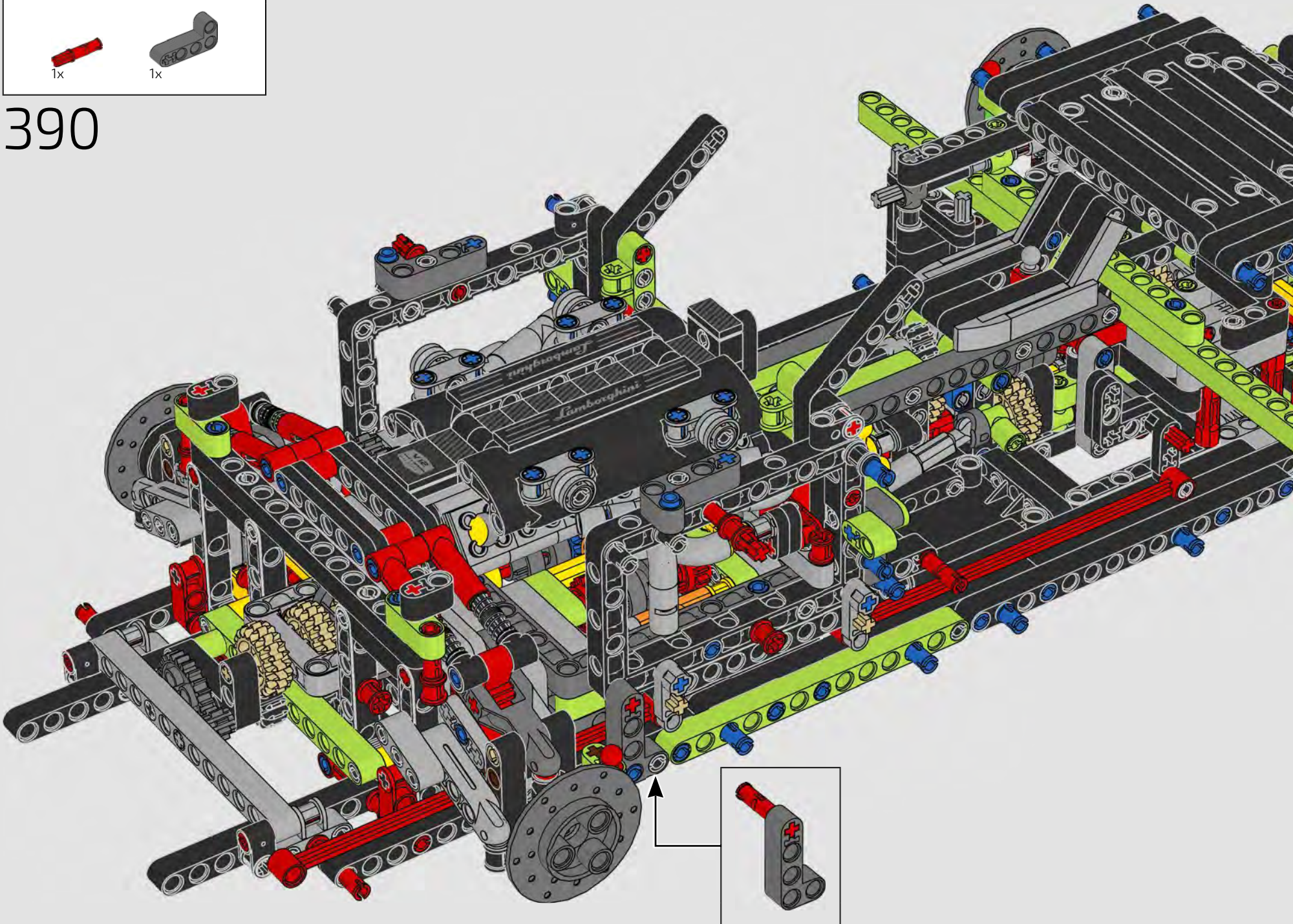

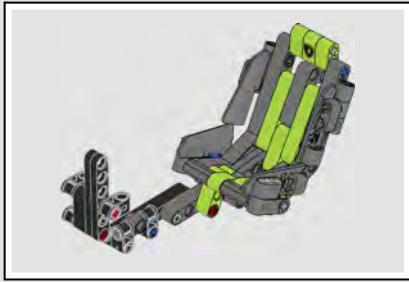

391

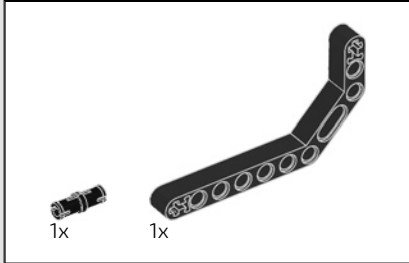

392

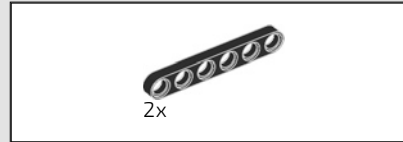
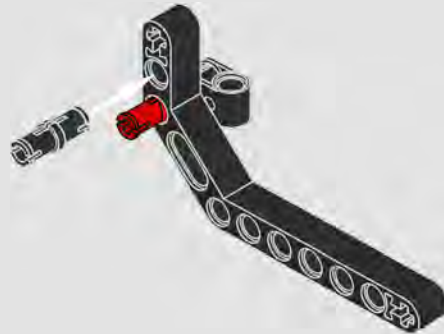

393

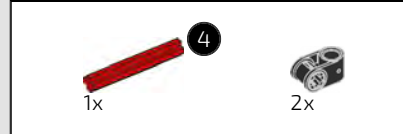
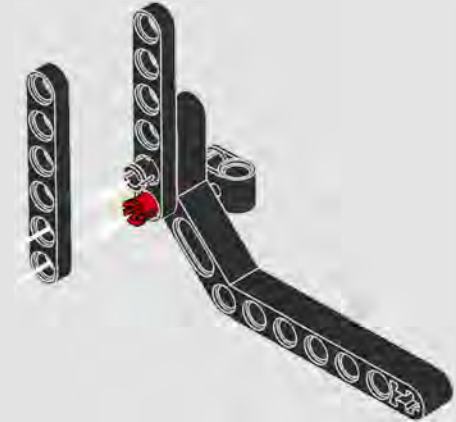

394

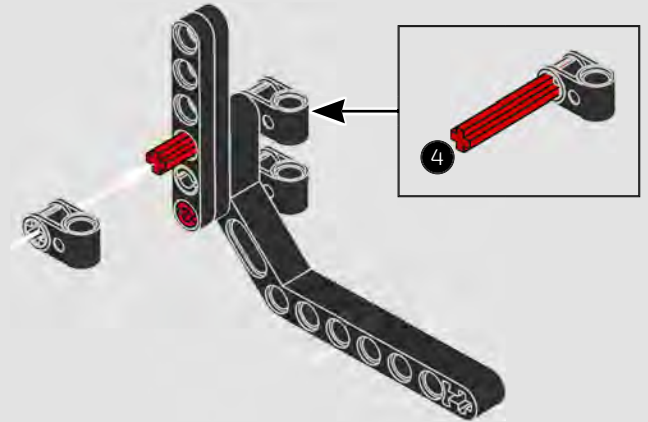

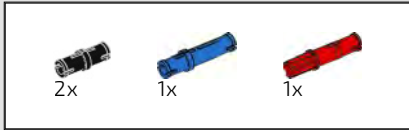

395

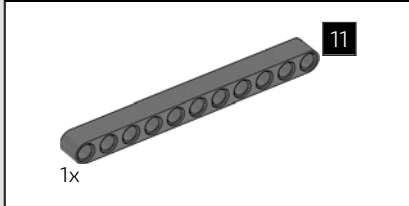
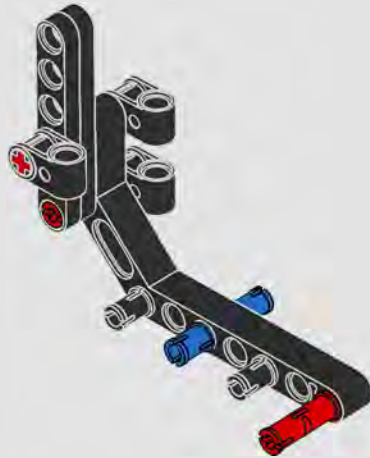

396

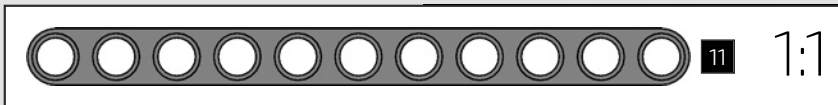
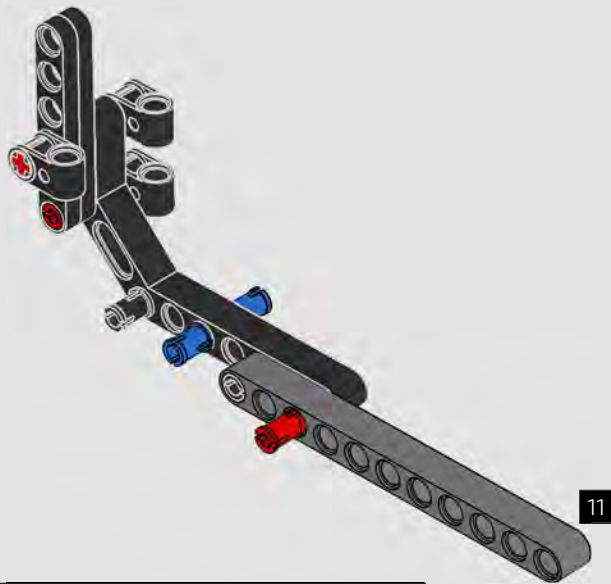

397

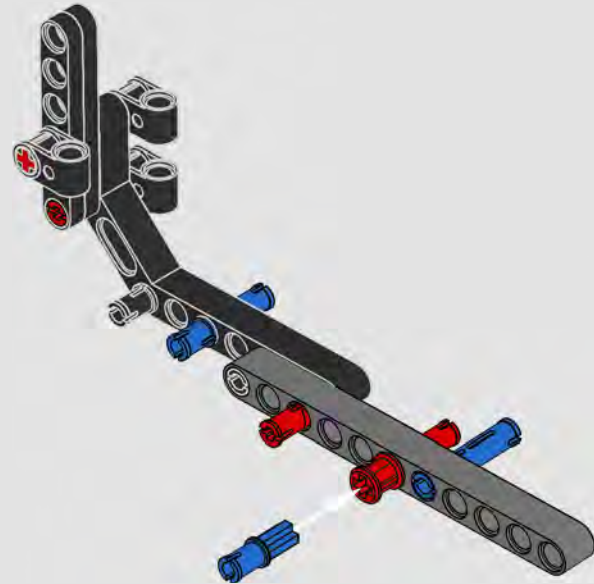

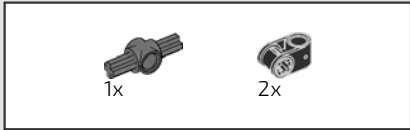

398

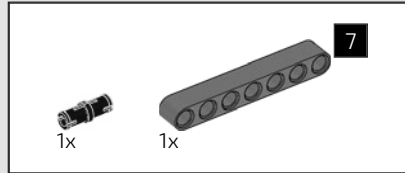
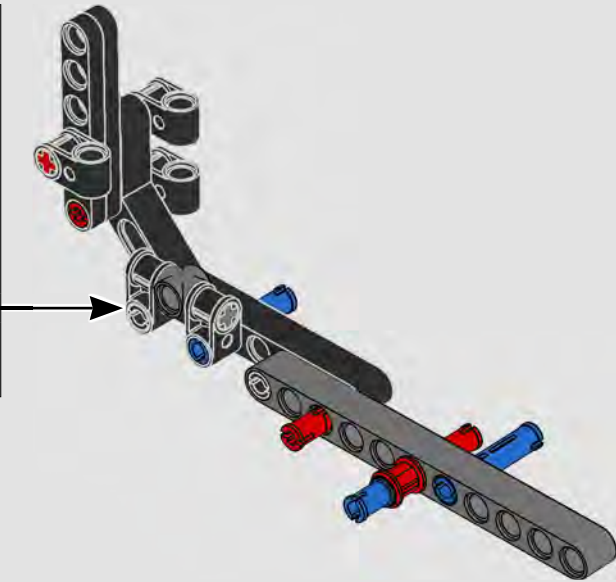
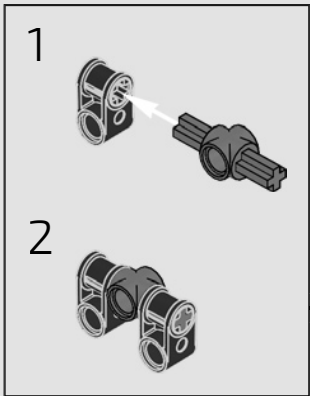

399

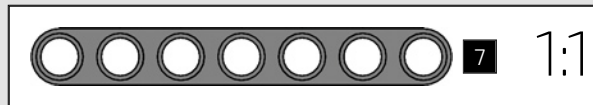
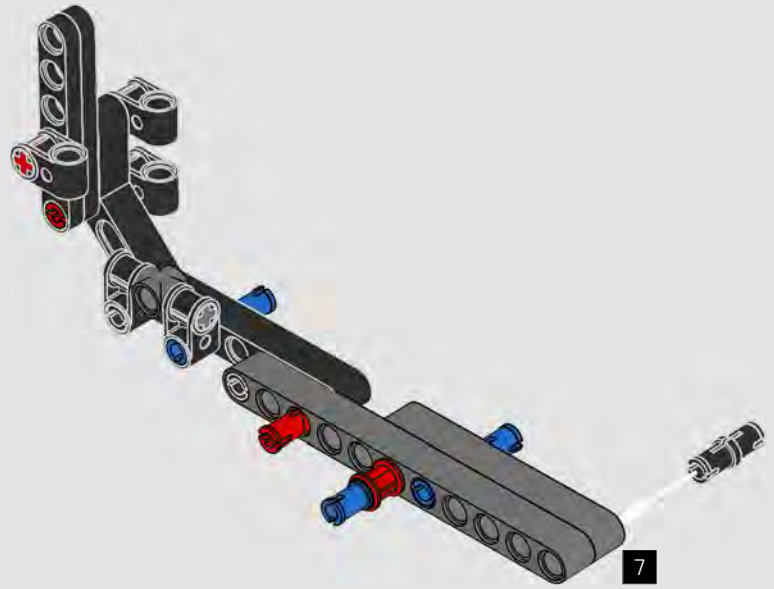

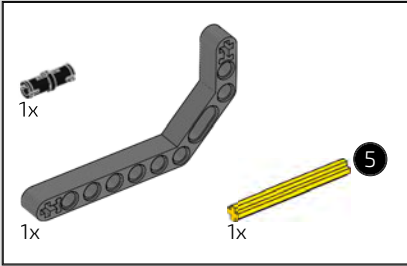
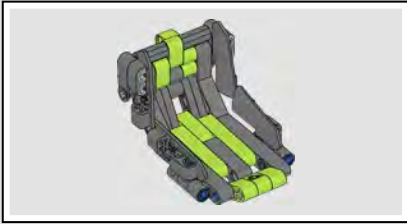

400

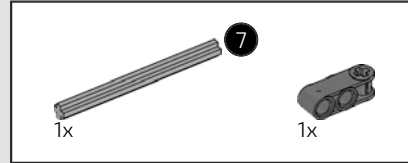
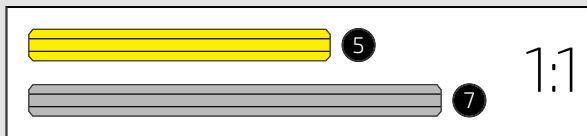
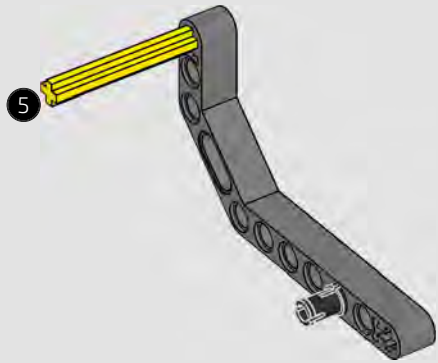

401

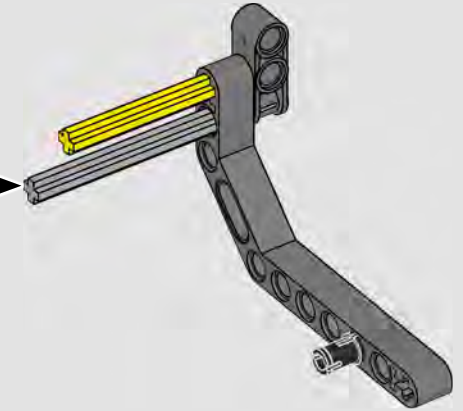
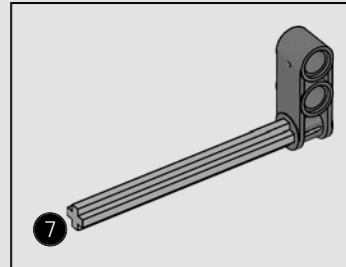

402

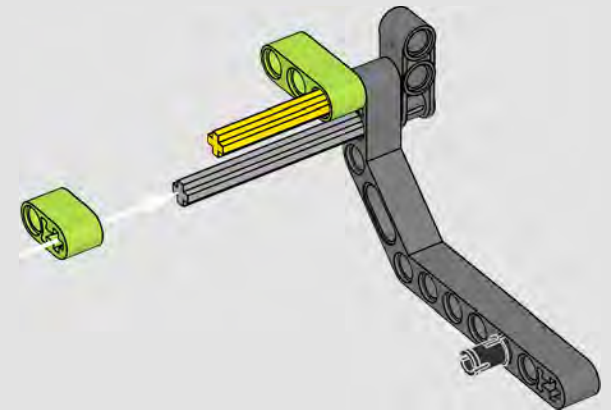

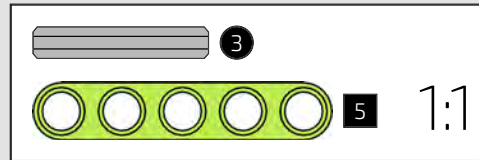
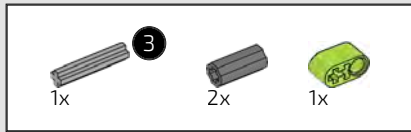

403

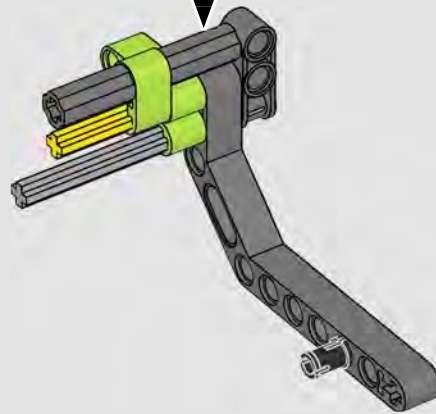
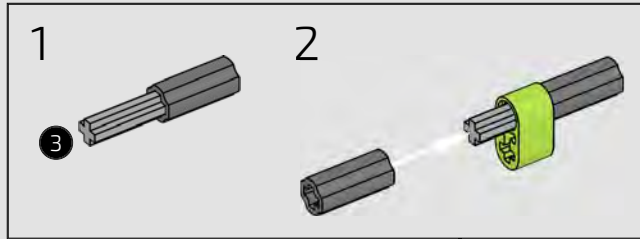

404

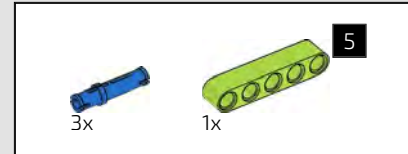
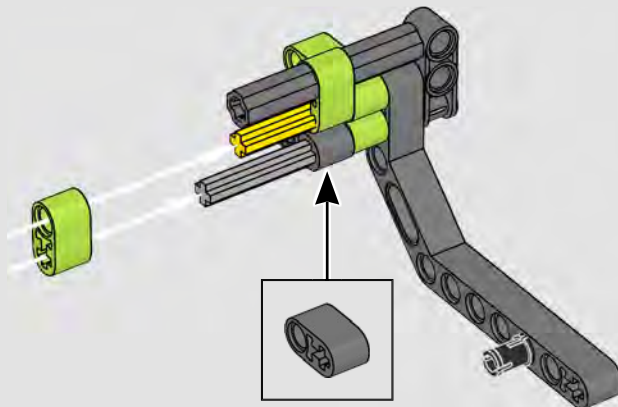

405

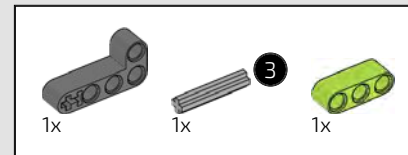
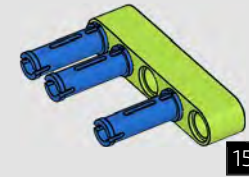

406

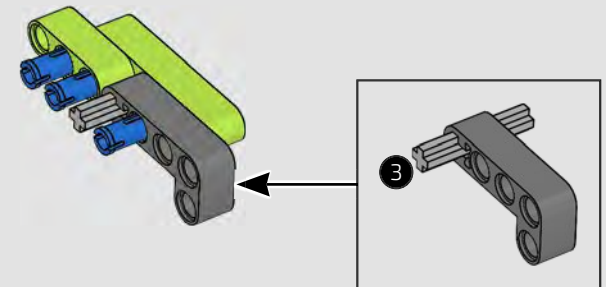

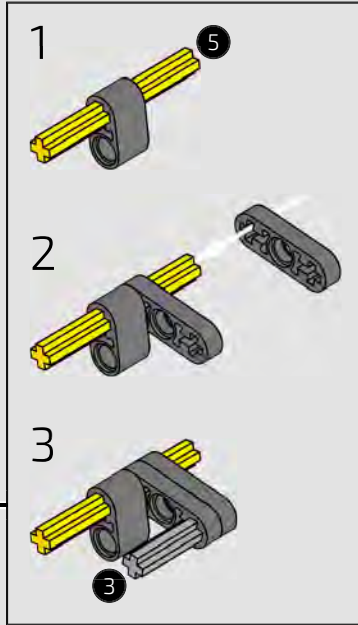
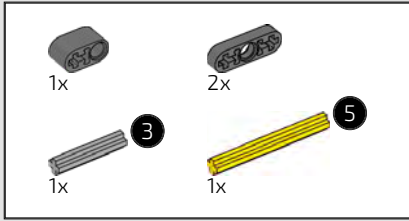

407

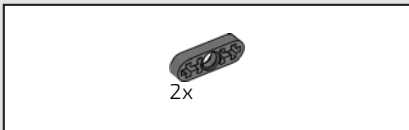
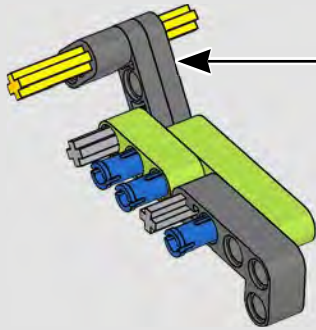

408

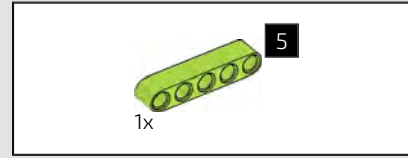
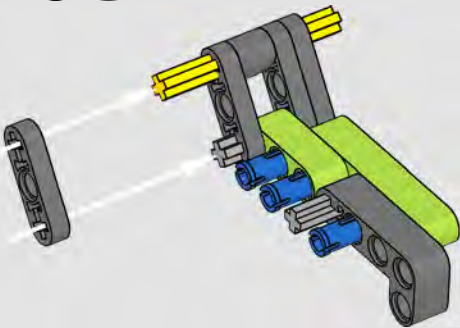

409

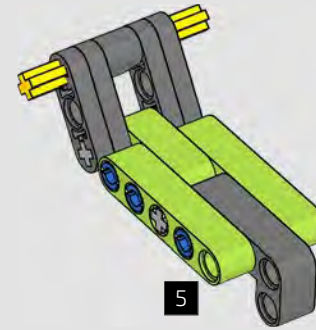
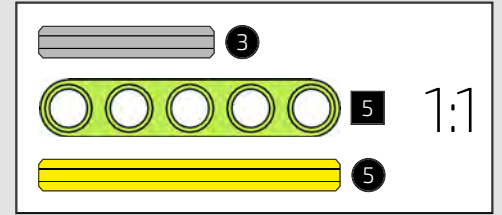

410

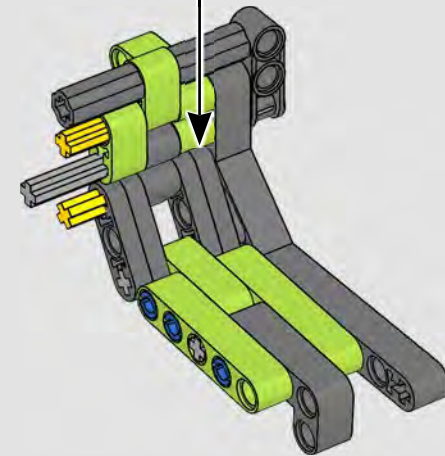

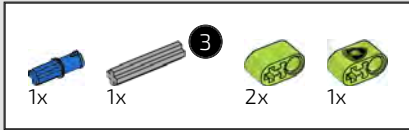

411

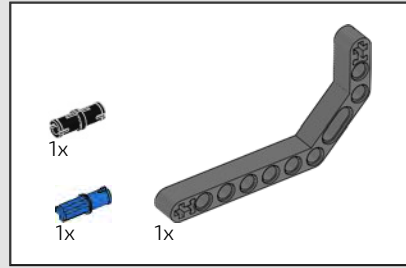
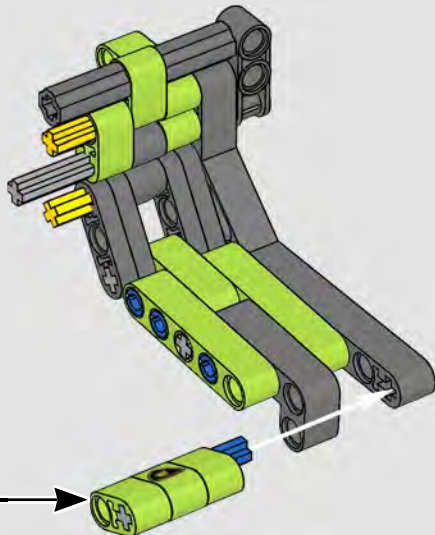
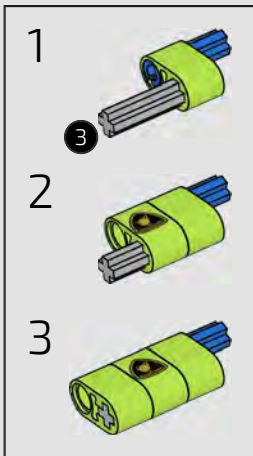

412

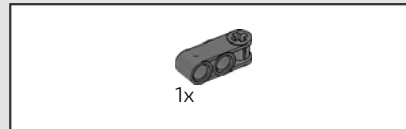
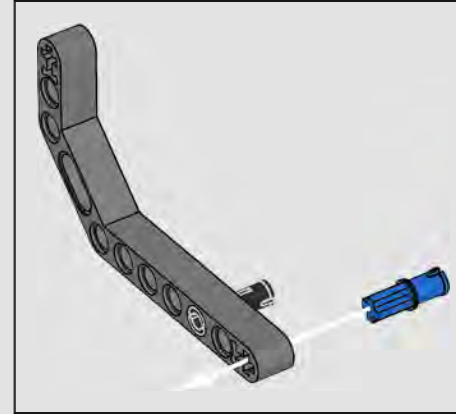

413

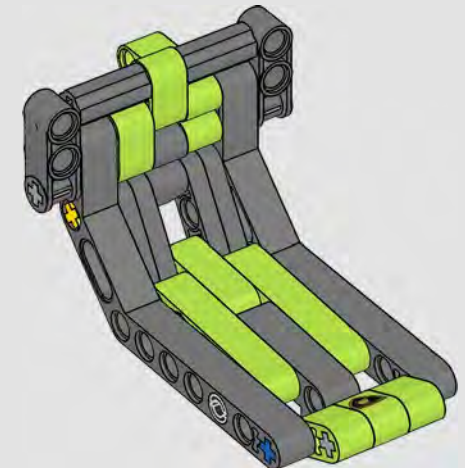
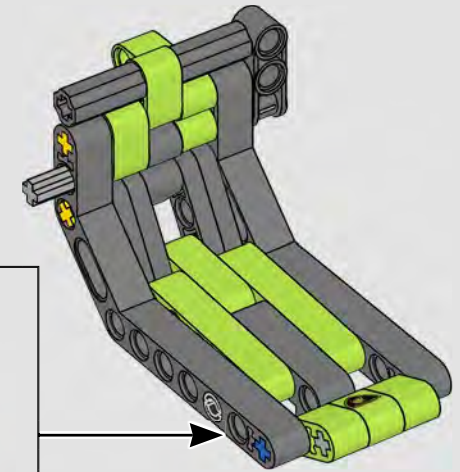



4x

414

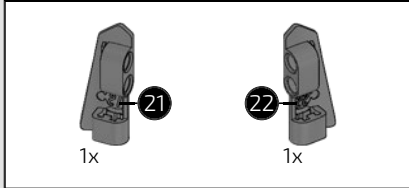
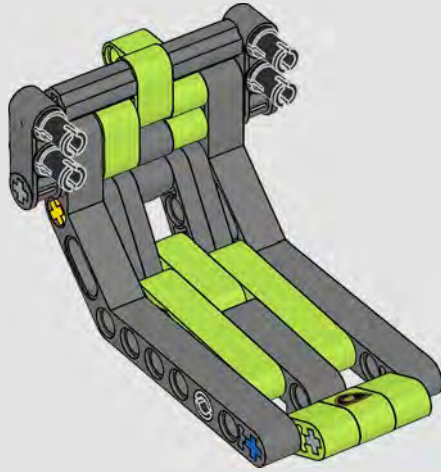

1x

21

22

1x

415

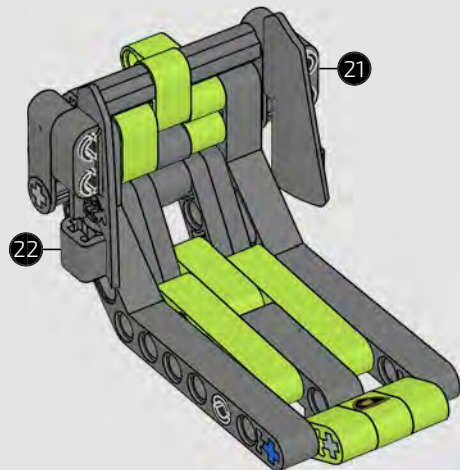

21

22

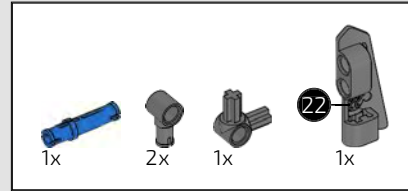

1x

2x

1x

1x

416

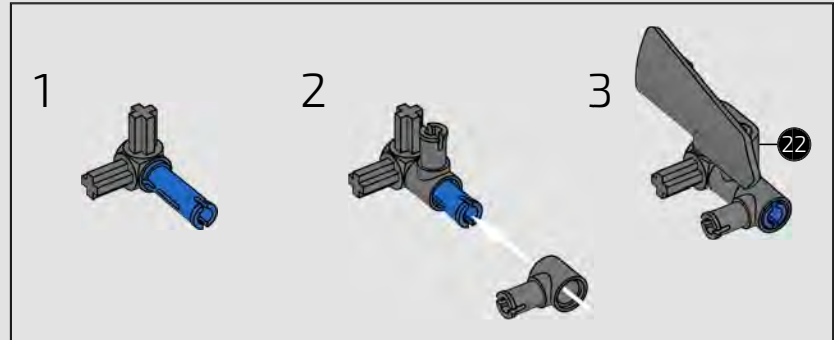

1

2

3

22

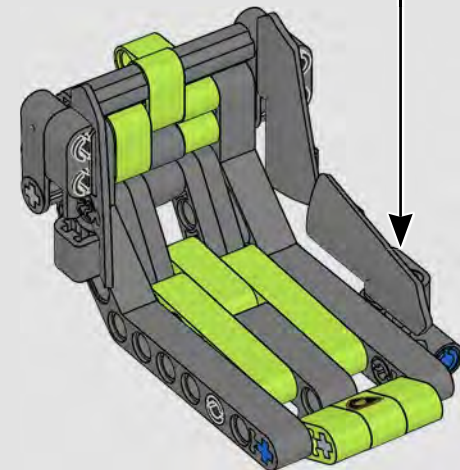

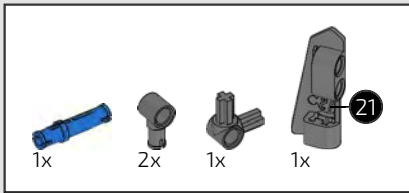

417

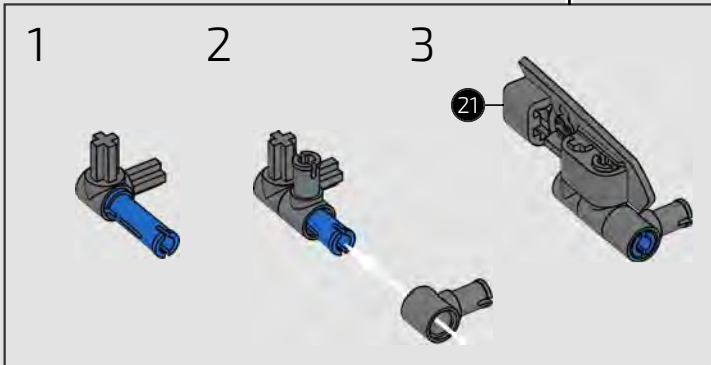
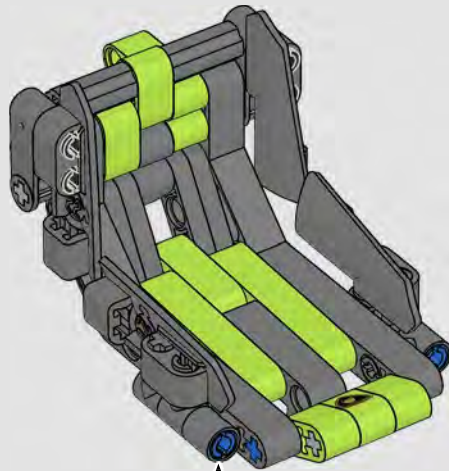

418

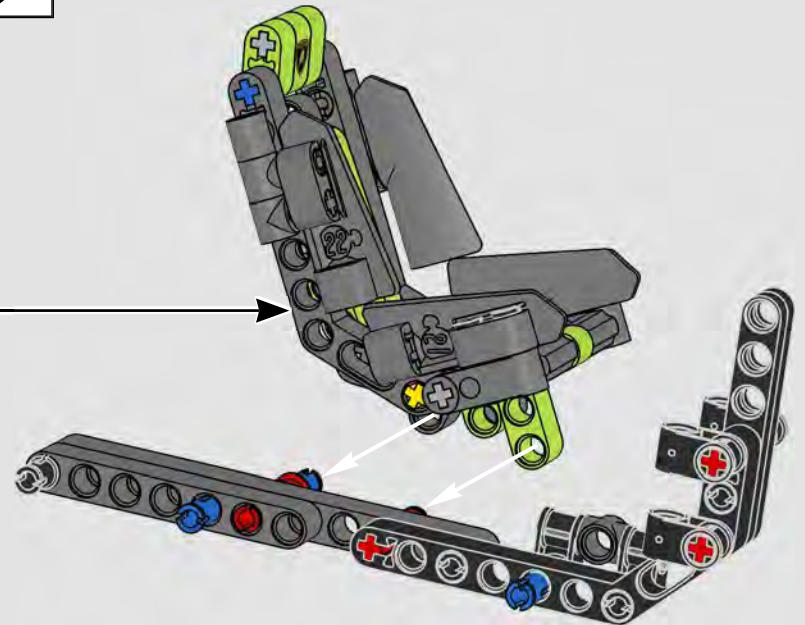
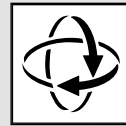

419

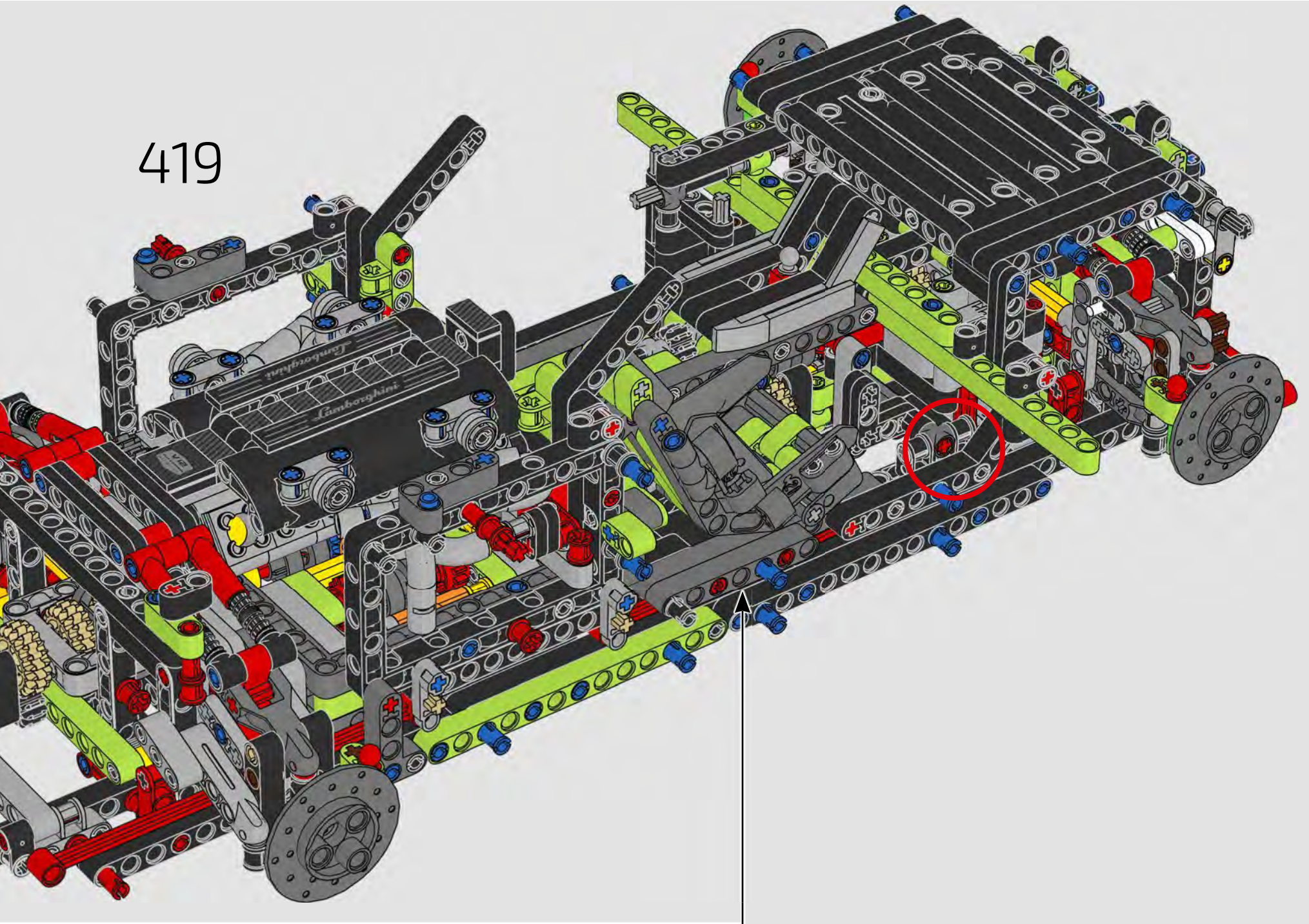



420

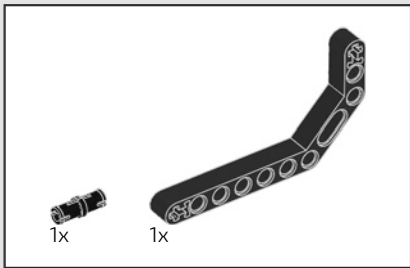

421

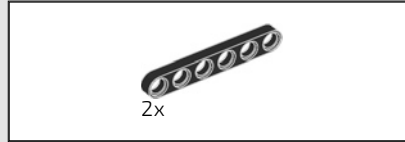

422

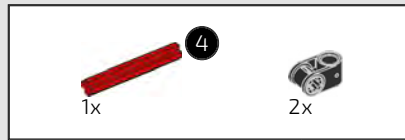

423

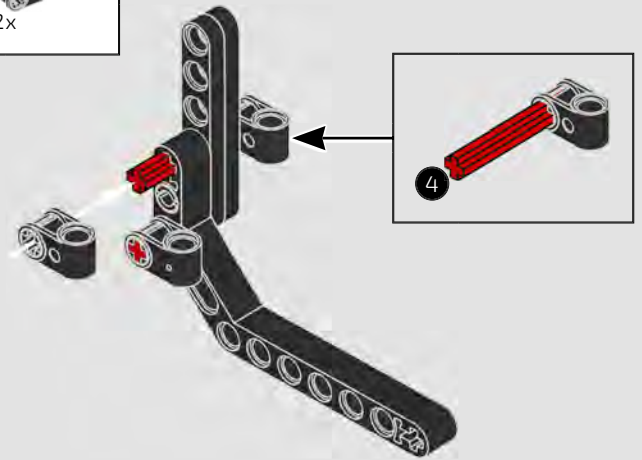

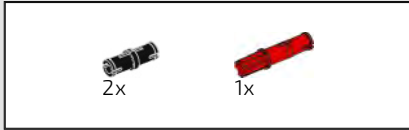

424

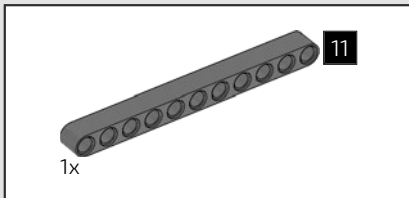
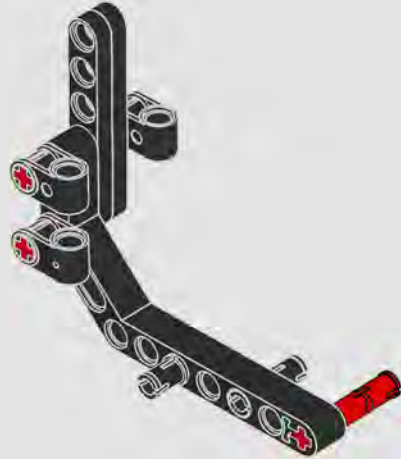

425

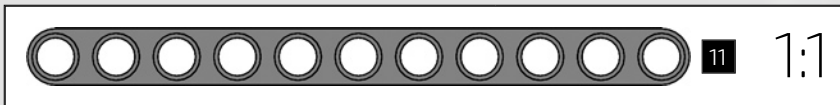
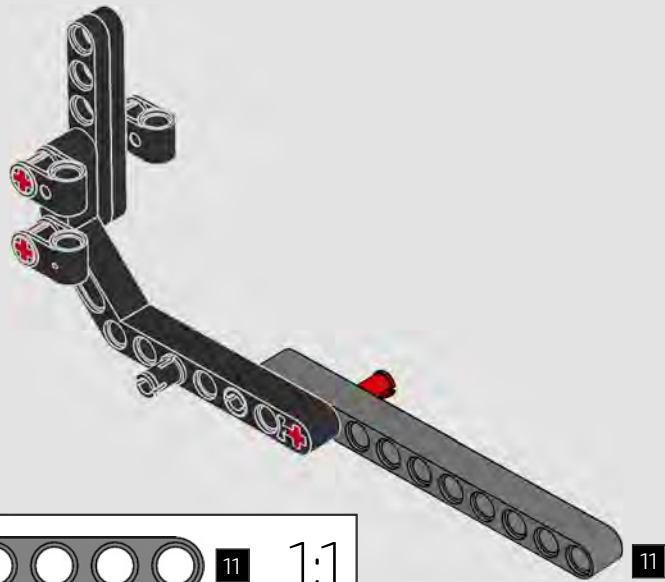

426

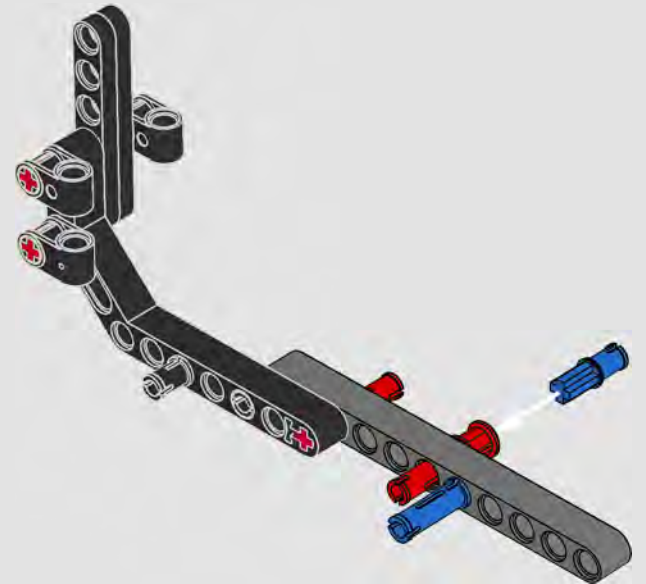

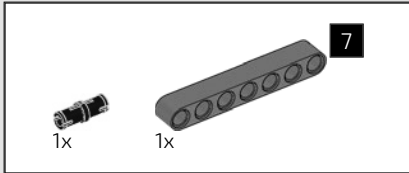

427

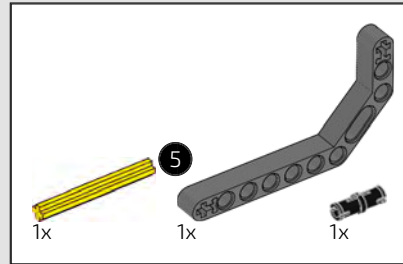
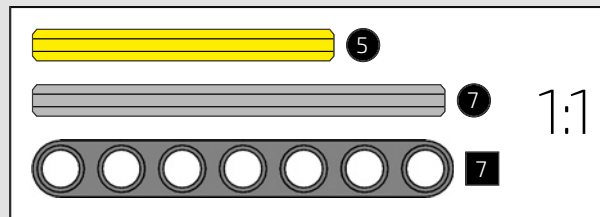
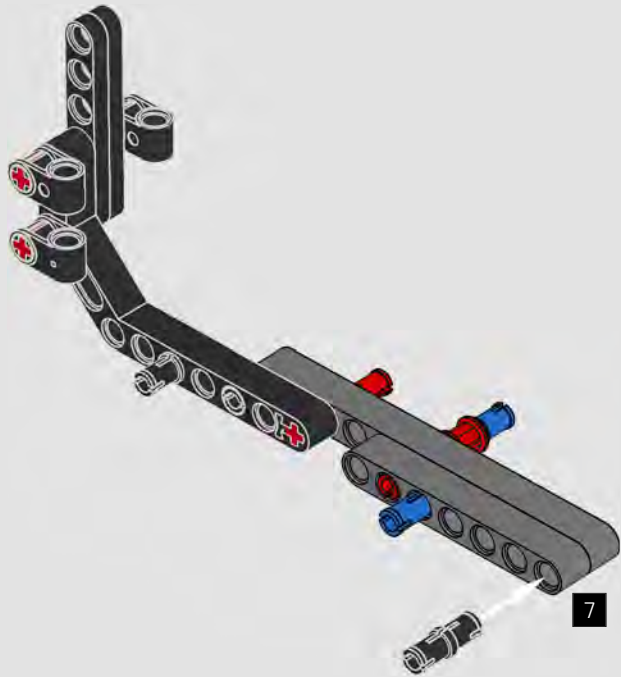

428

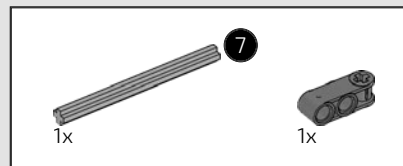
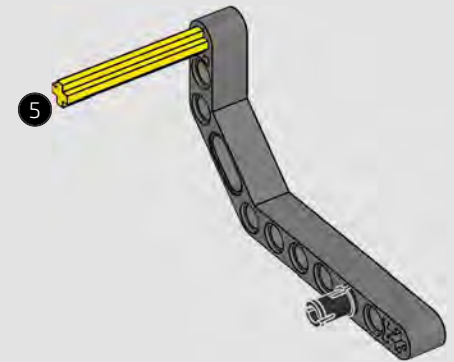

429

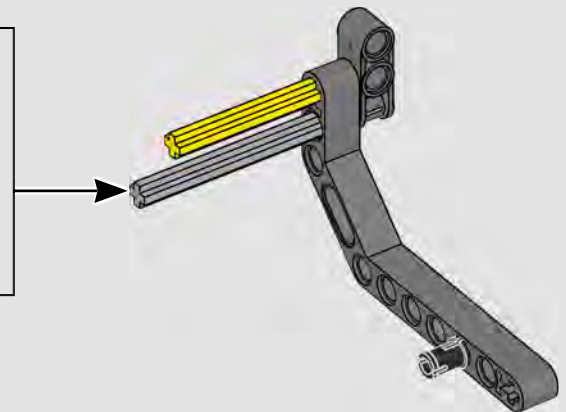
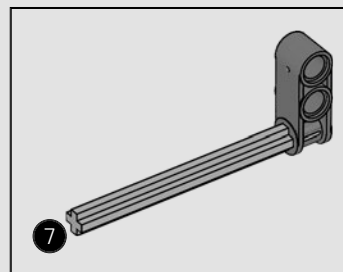

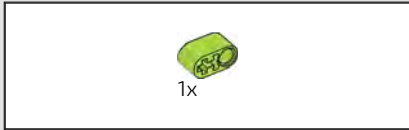

430

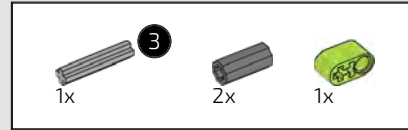
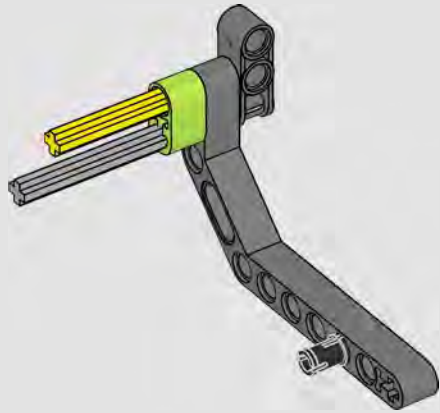

431

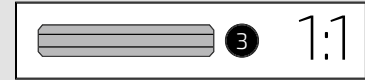
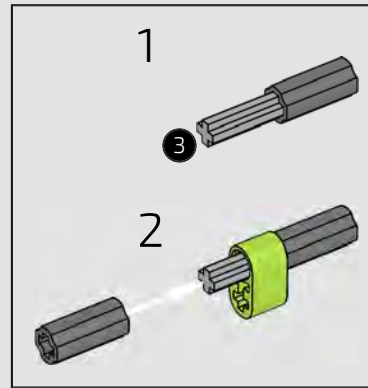

432

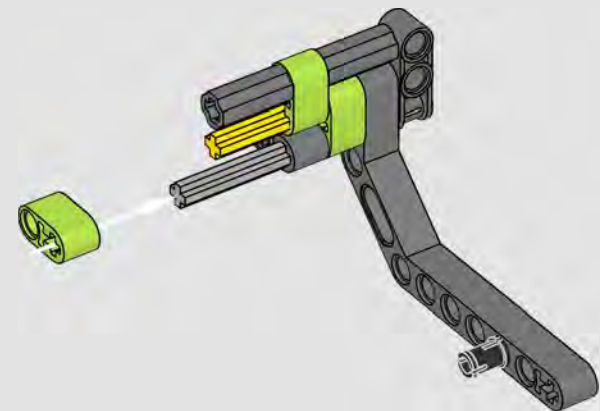

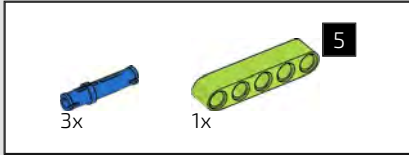
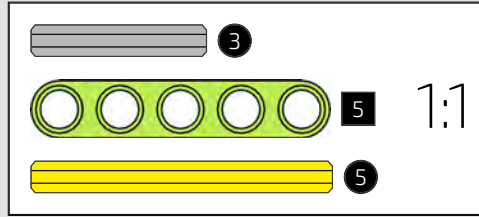
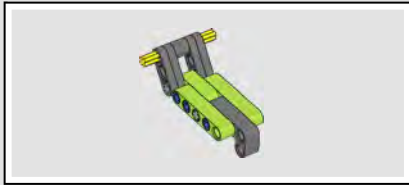

433

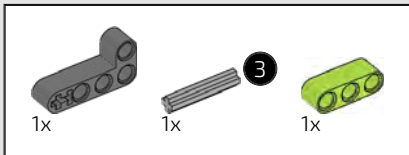
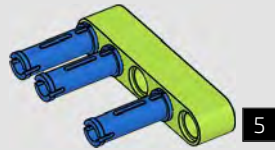

434

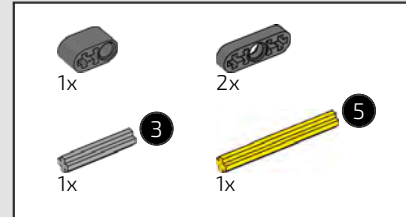
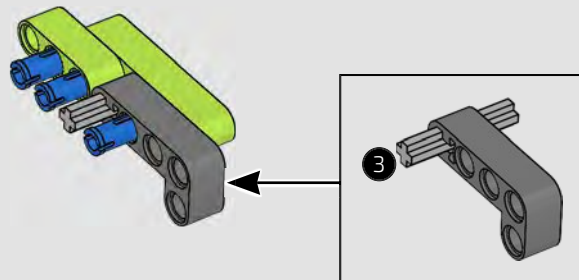

435

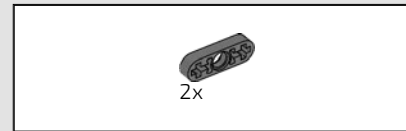
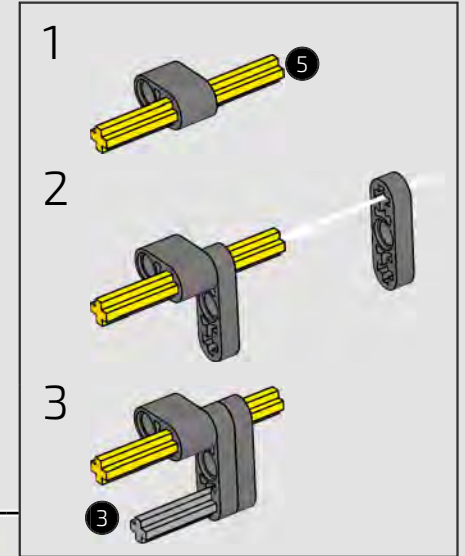
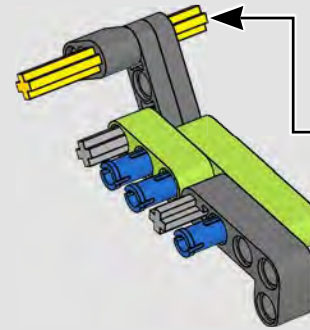

436

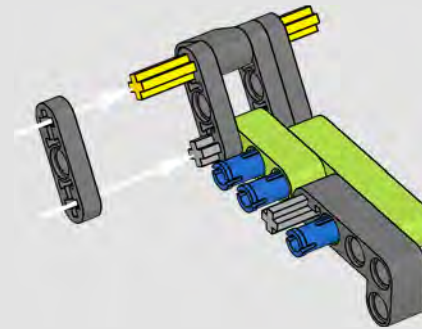

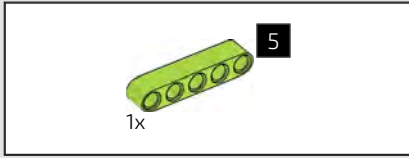

437

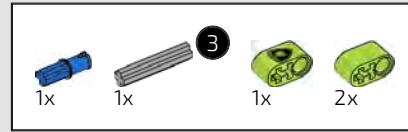
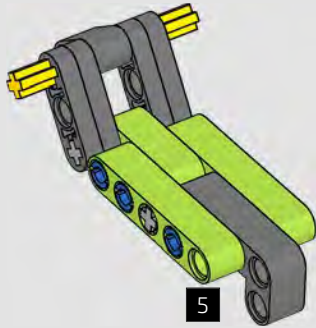
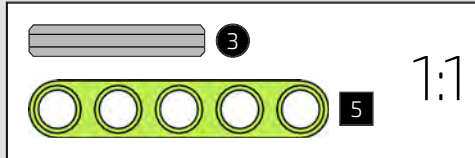

439

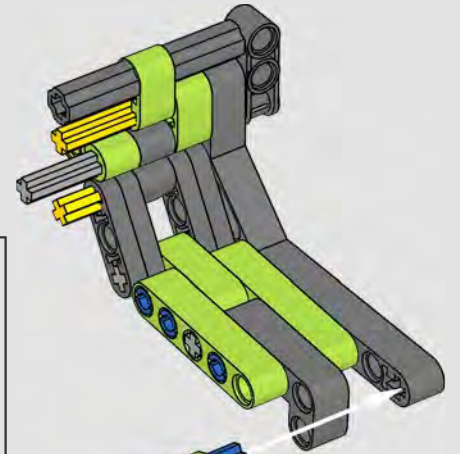

438

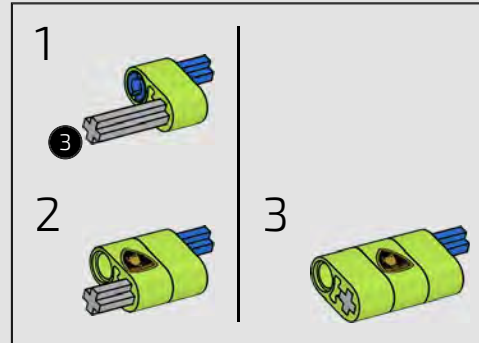
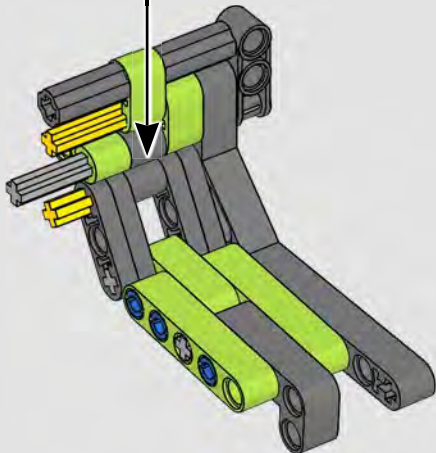

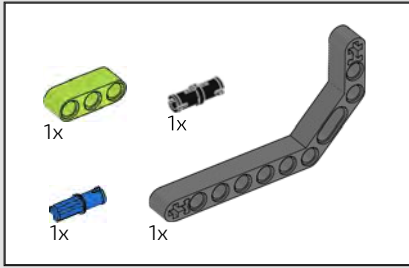

440

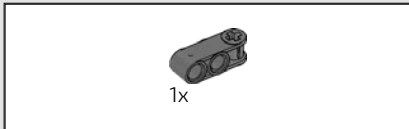
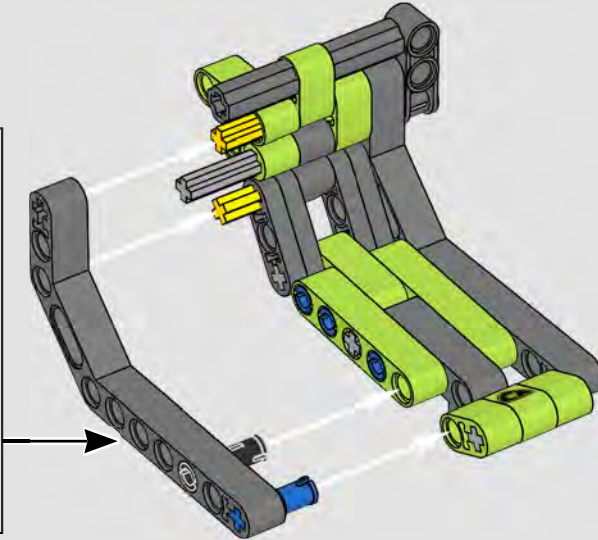
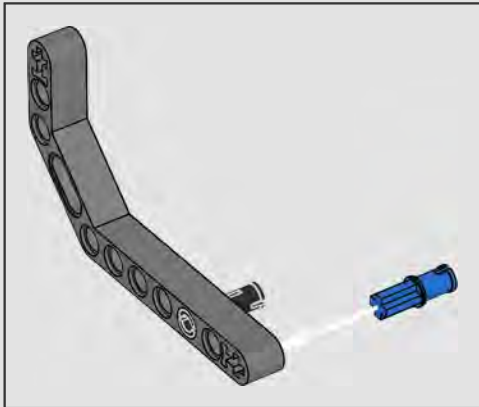

441

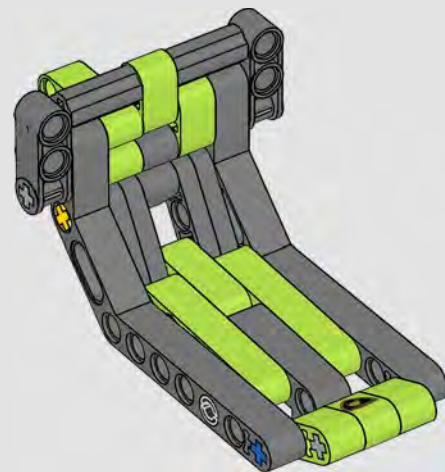

442

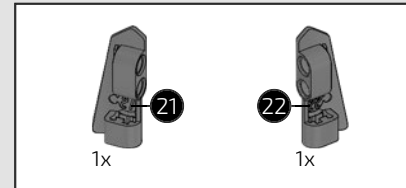
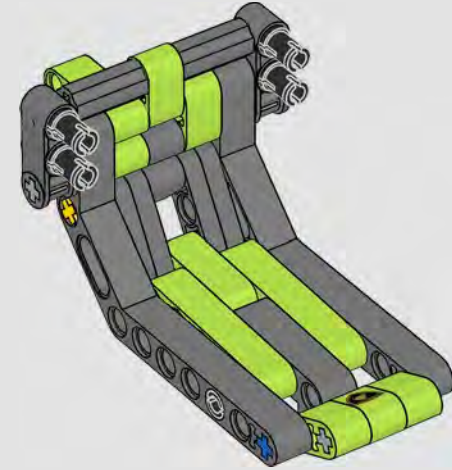

443

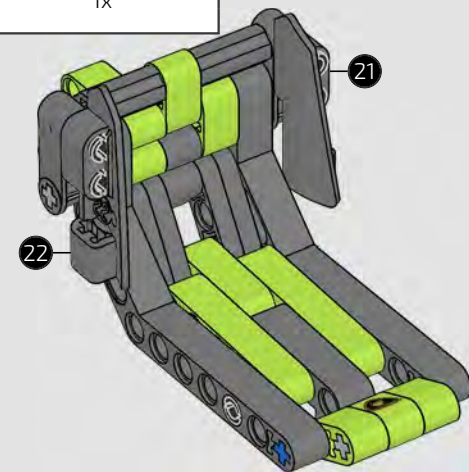

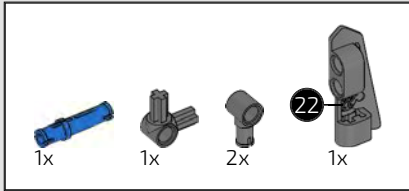

444

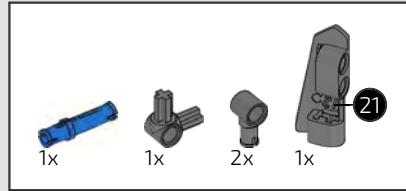
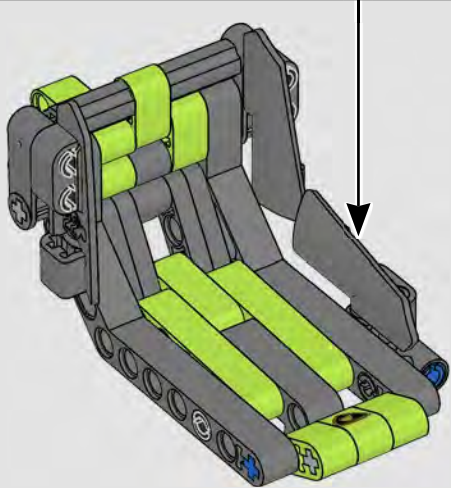
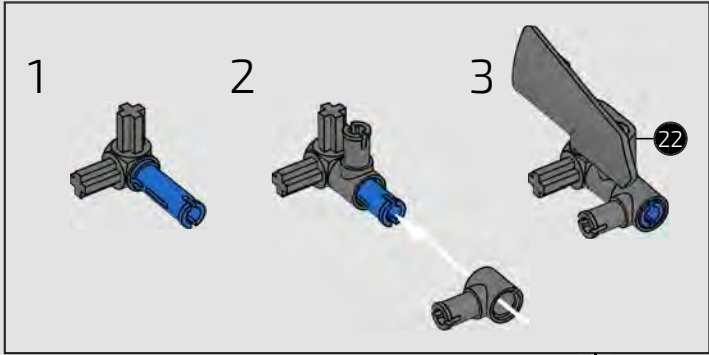

445

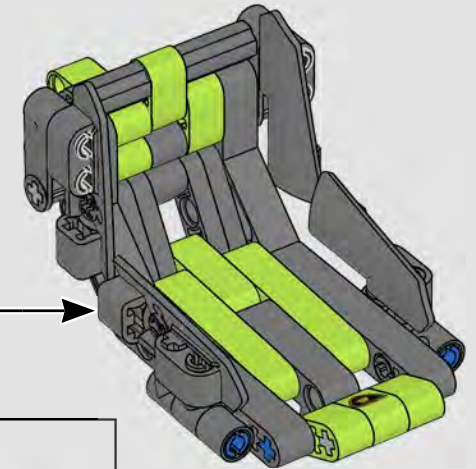
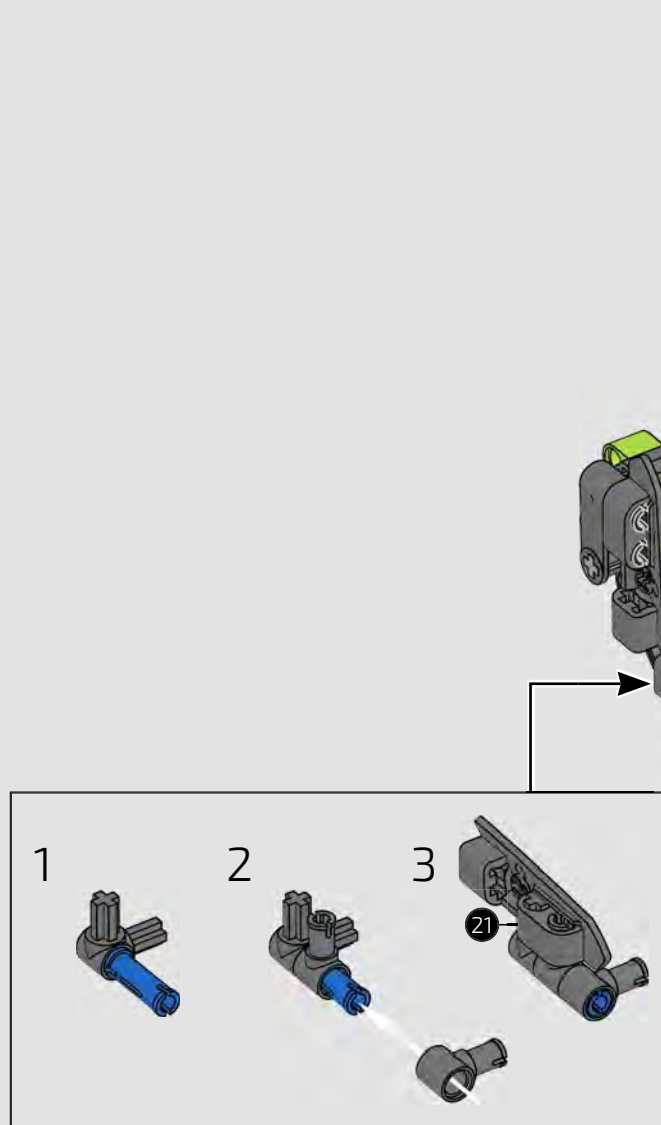

446

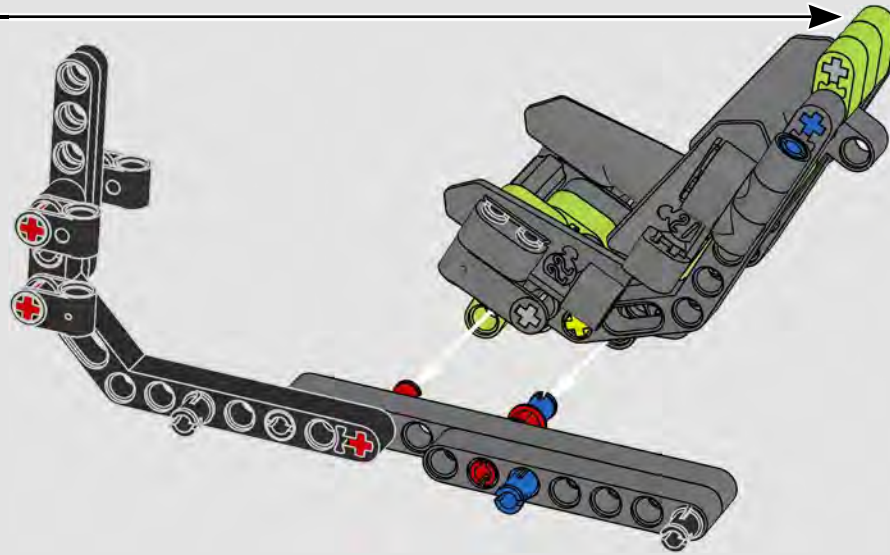

447

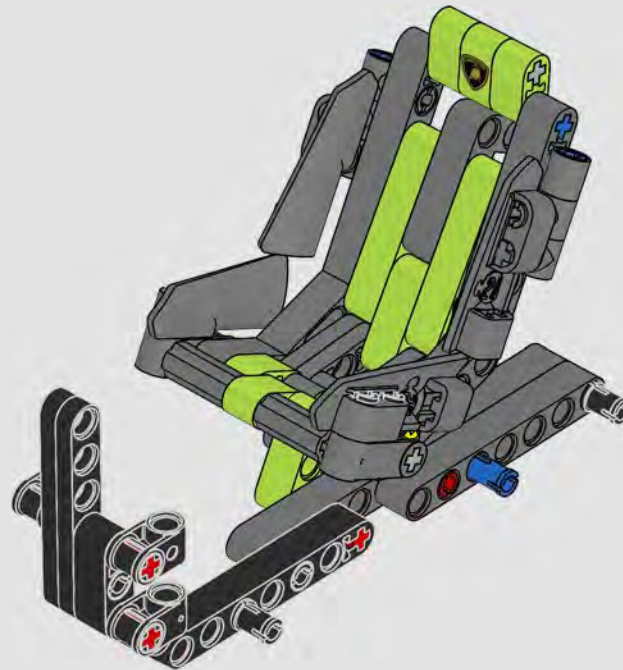

448

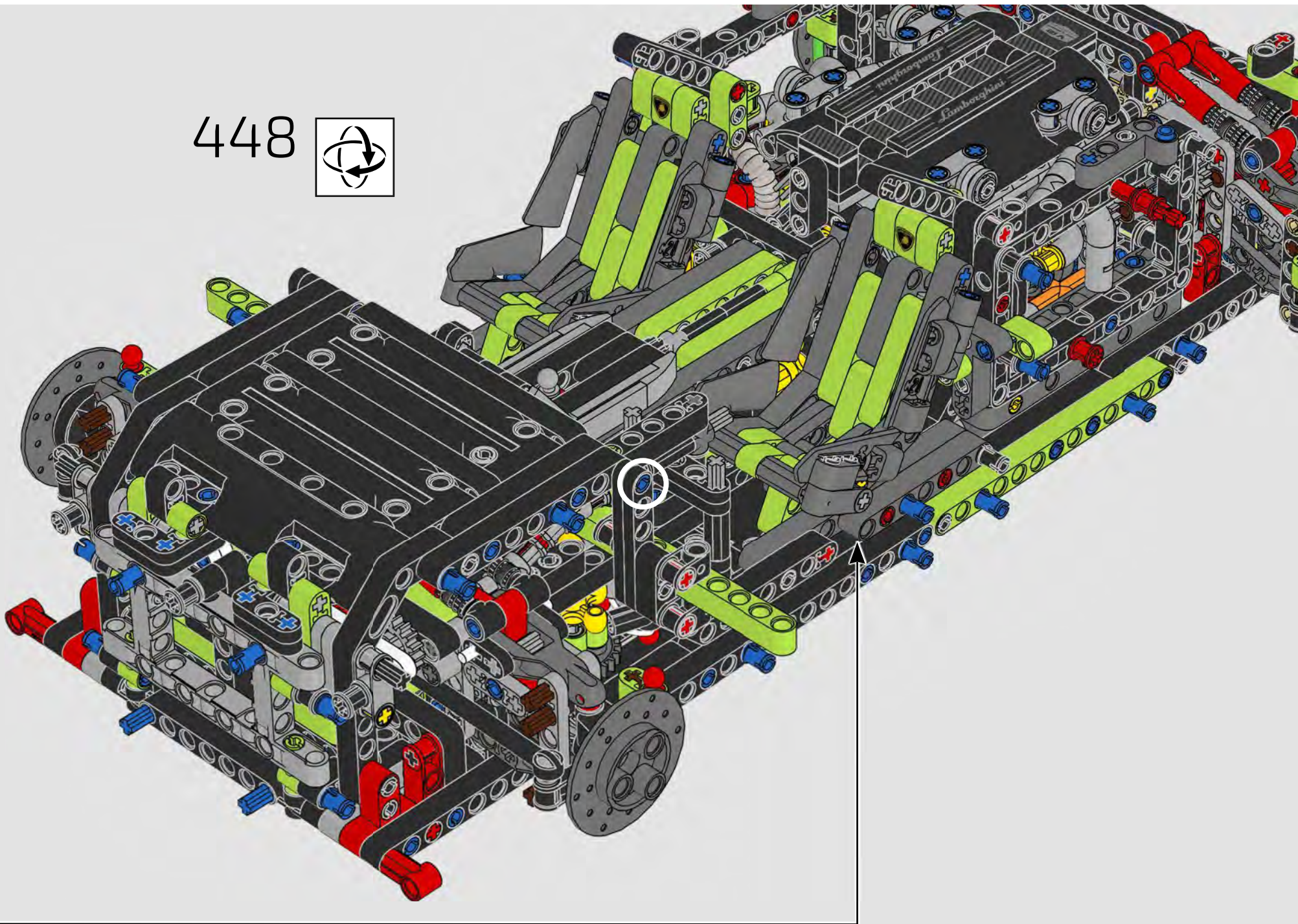
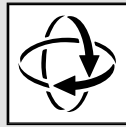

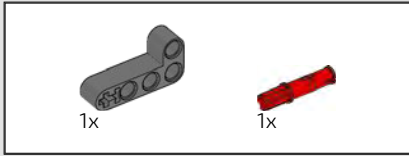

449

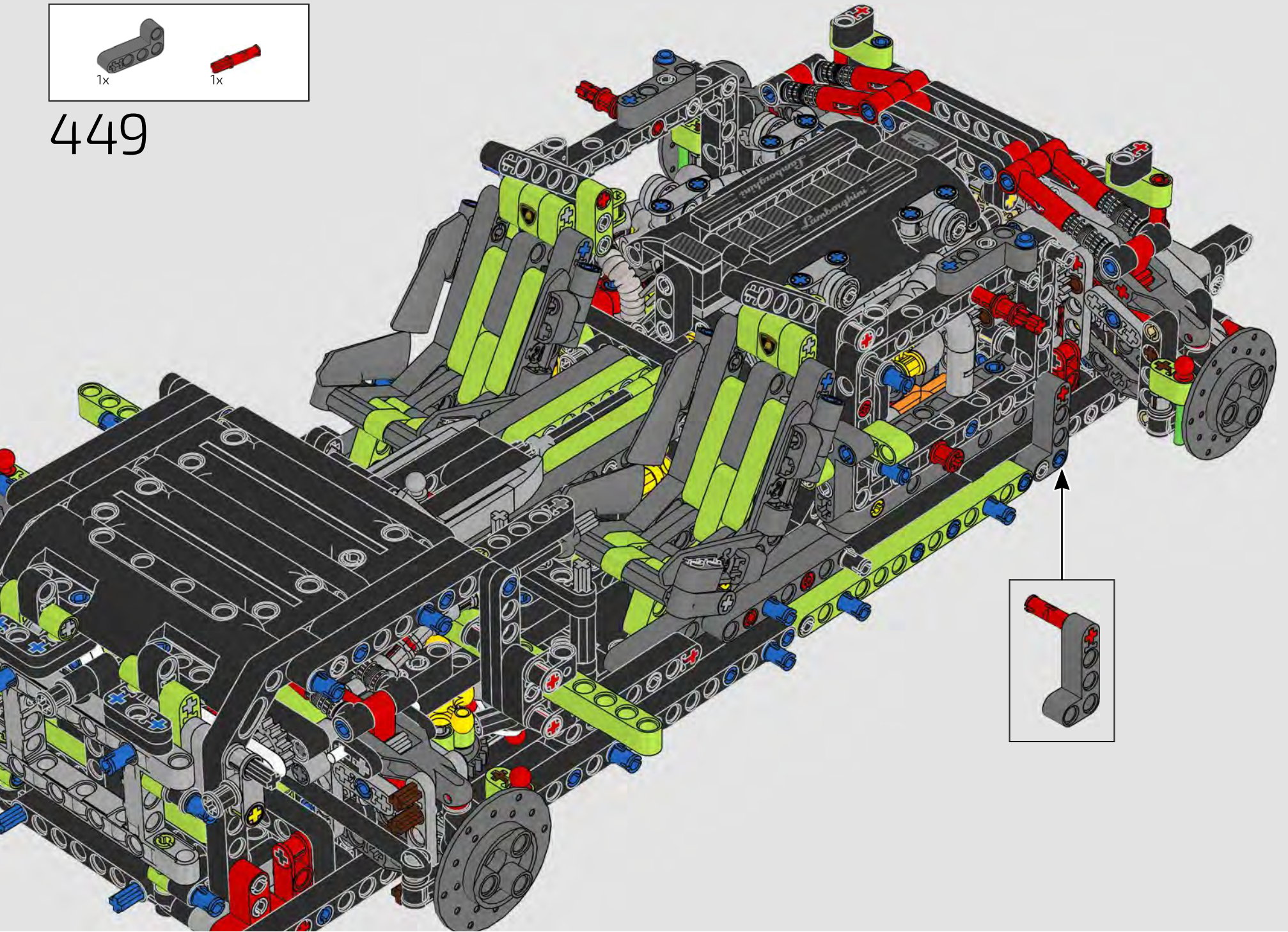



450

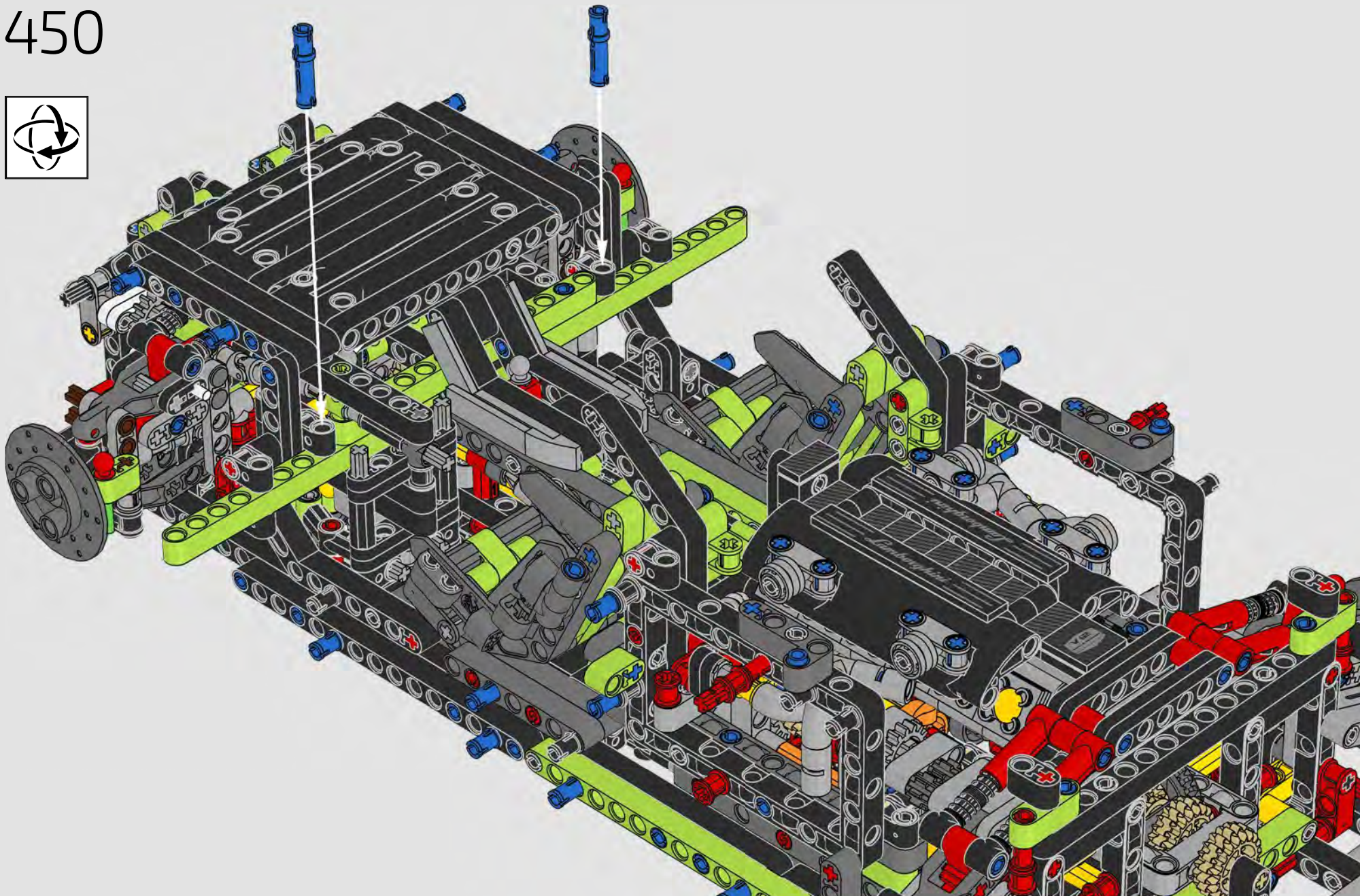

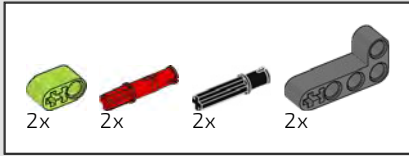

451

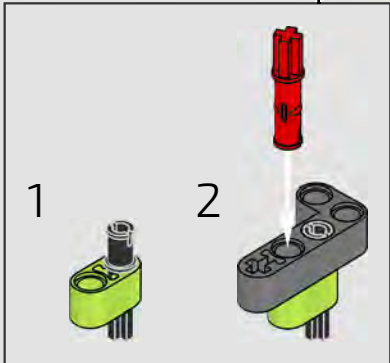
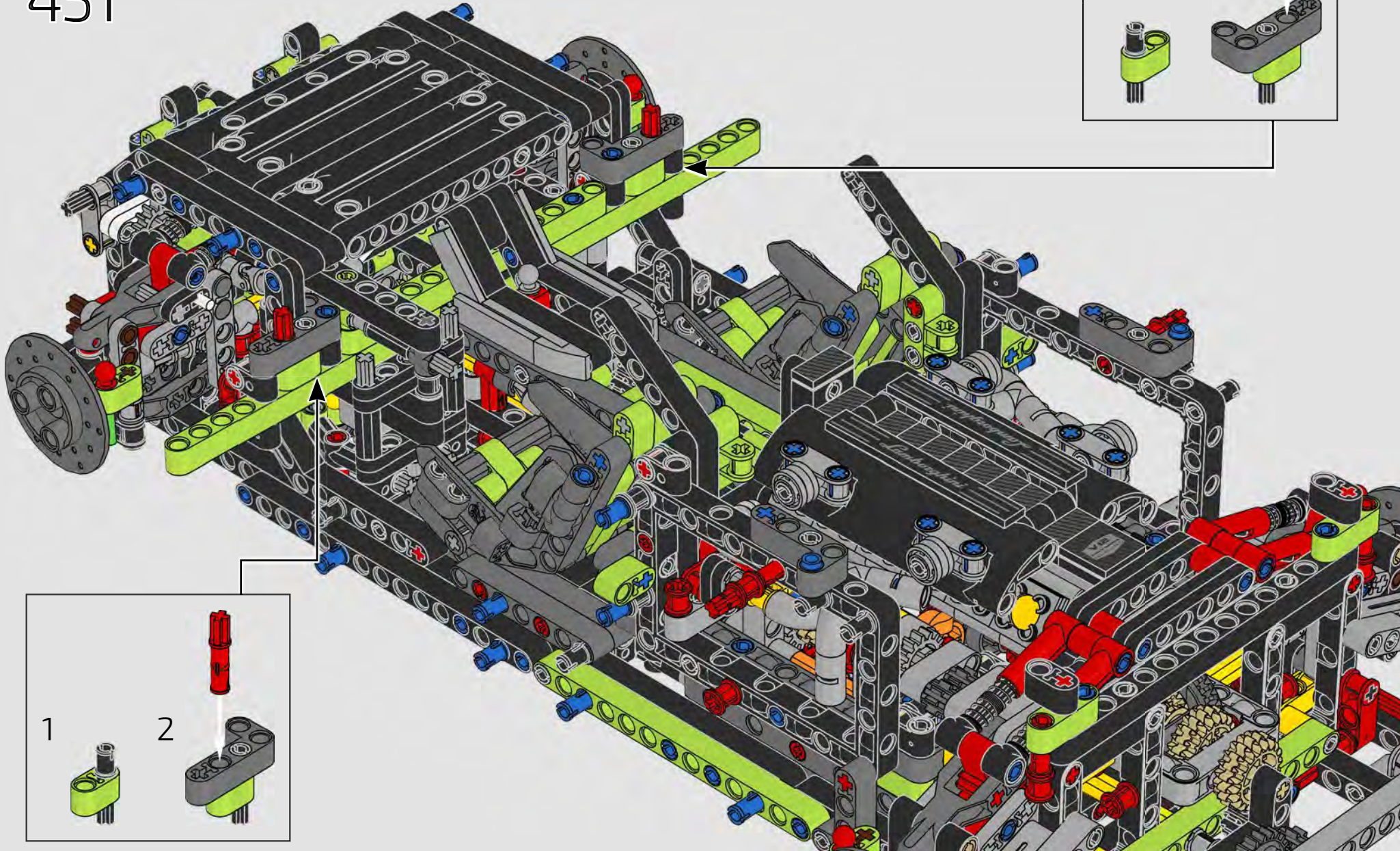
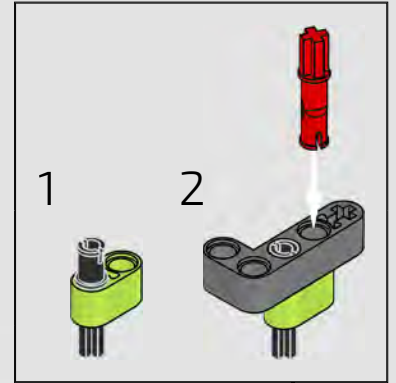

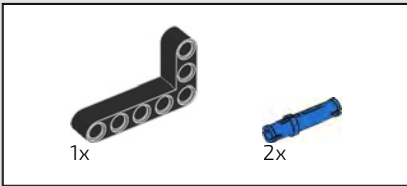
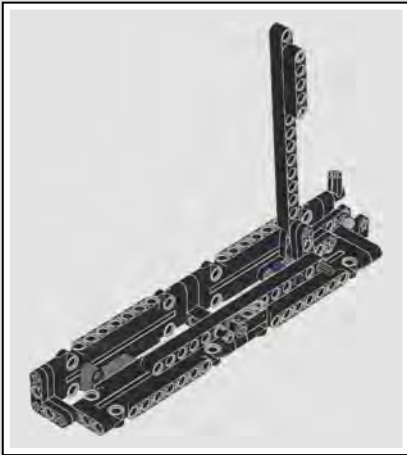

452

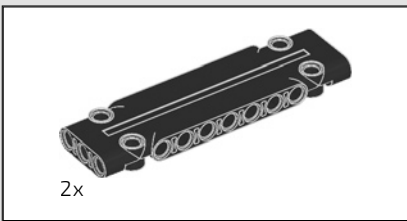

453

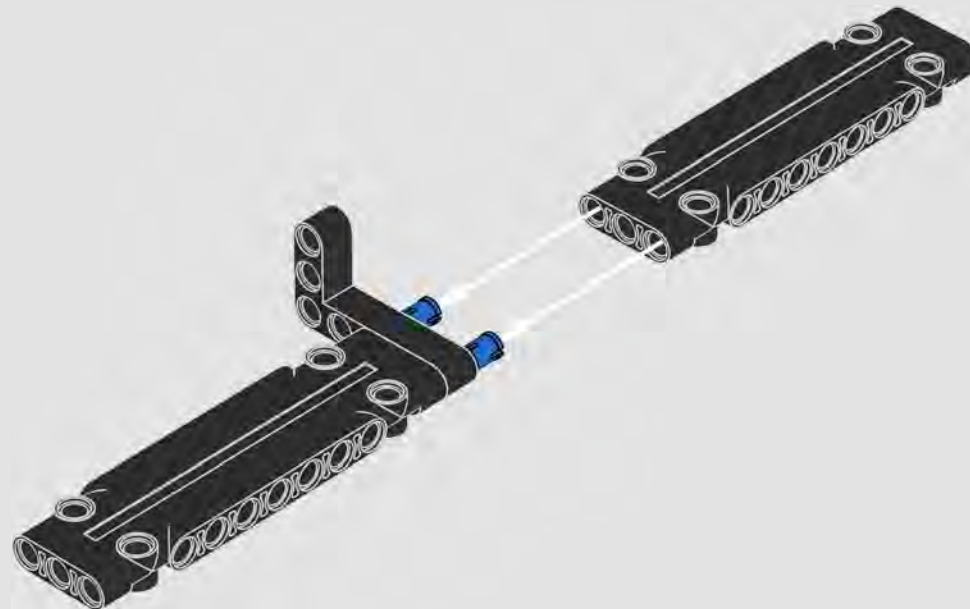
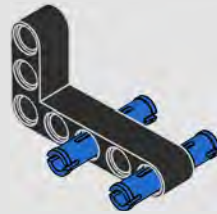

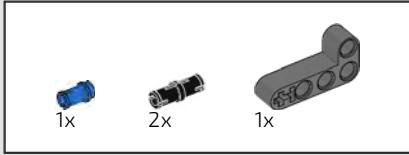

454

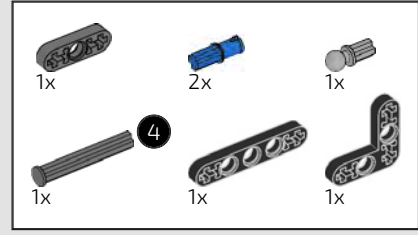
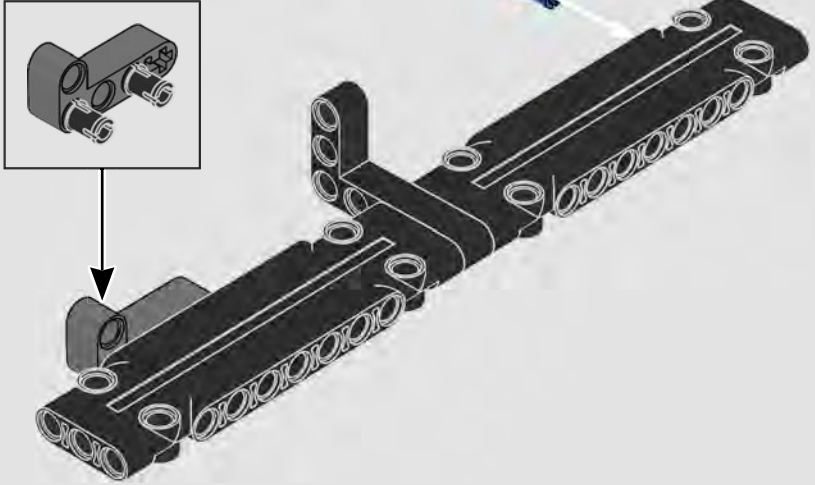

455

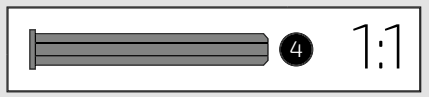
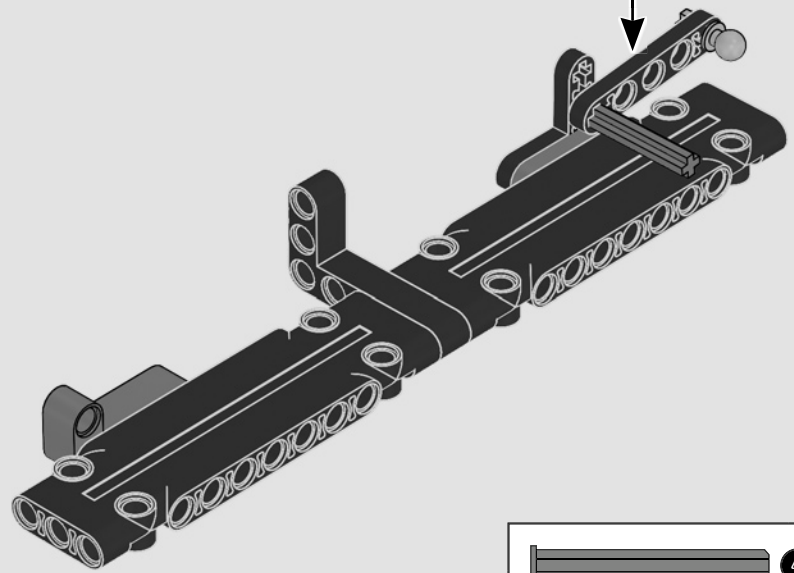
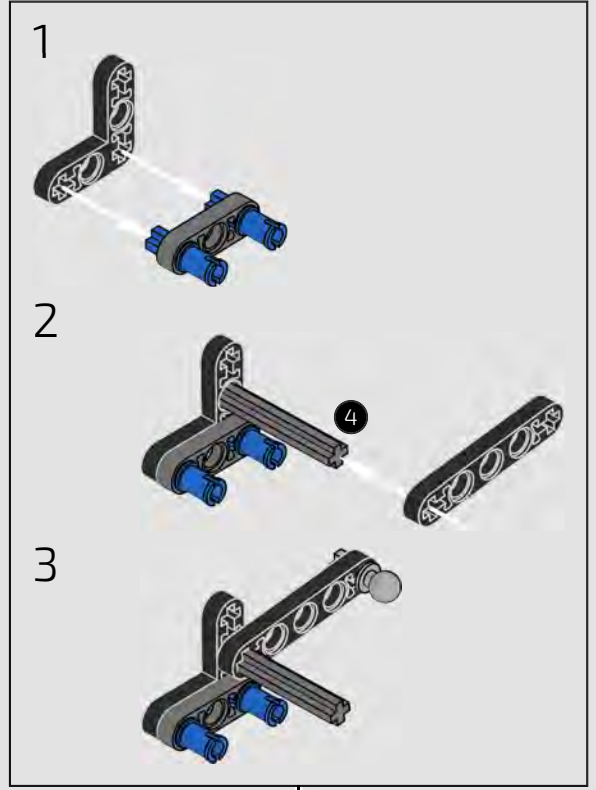
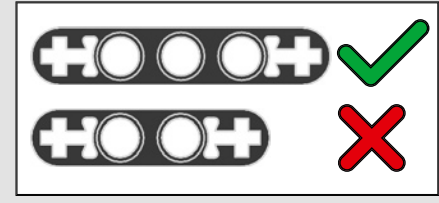



456

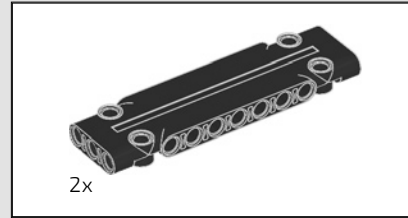
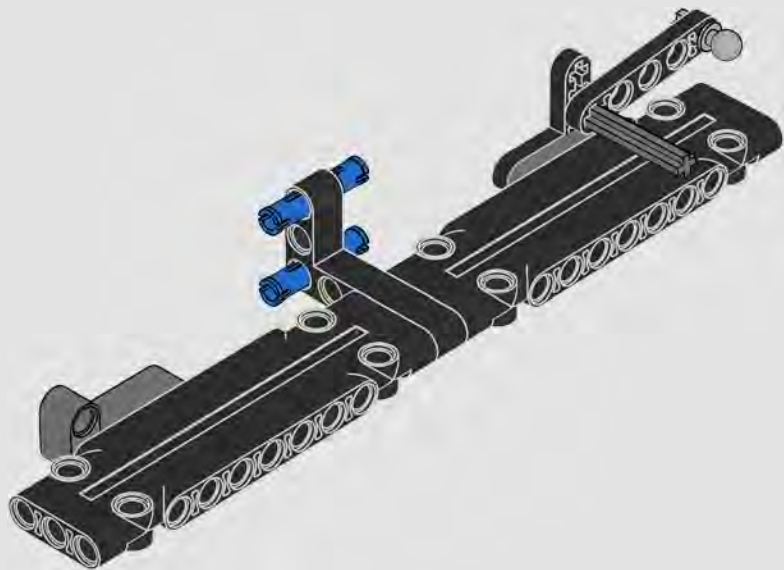

457

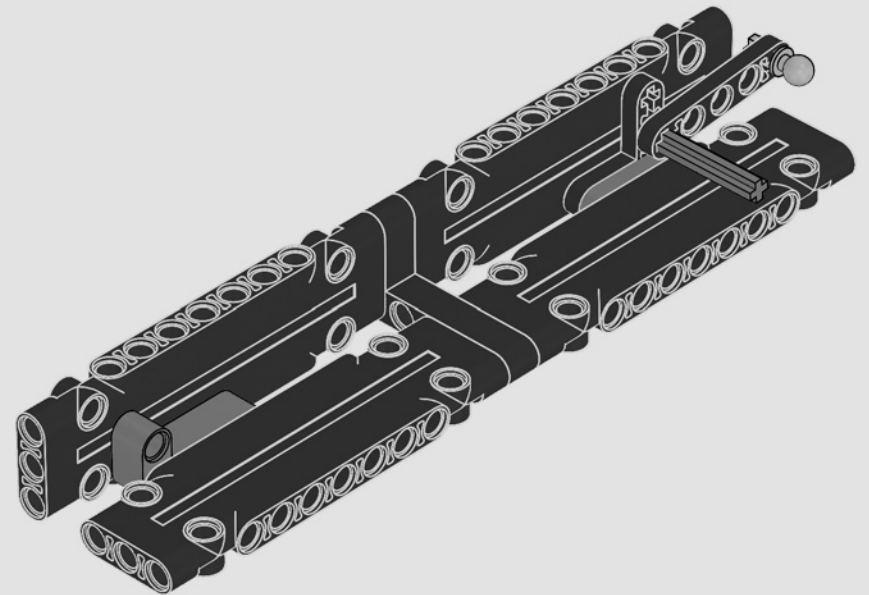

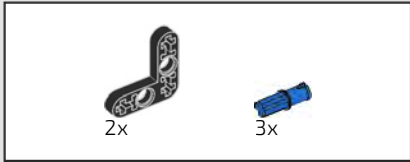

458

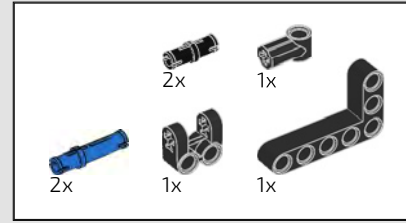
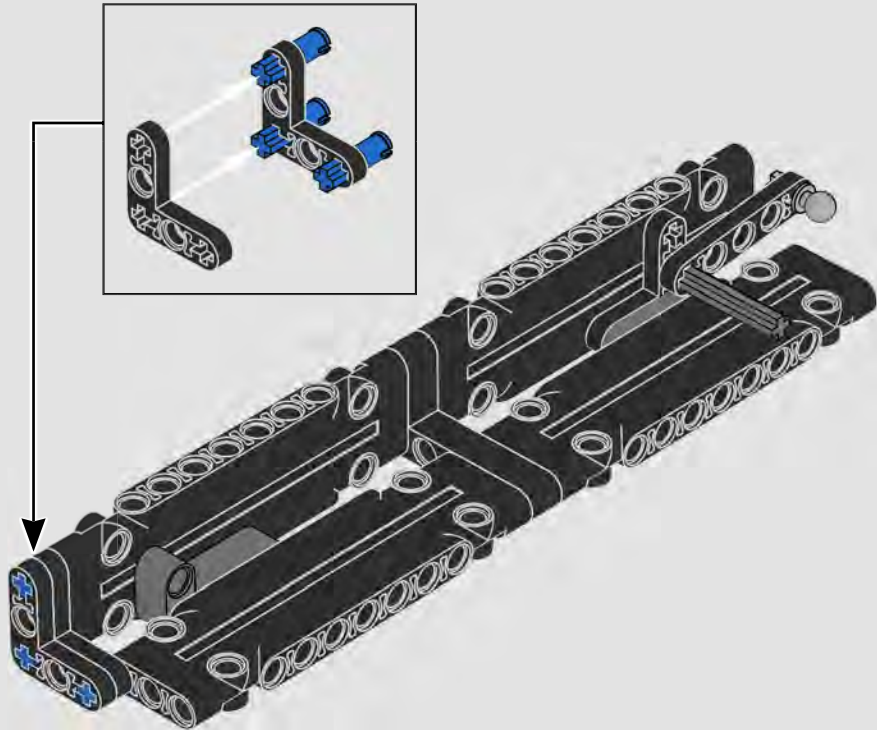

459

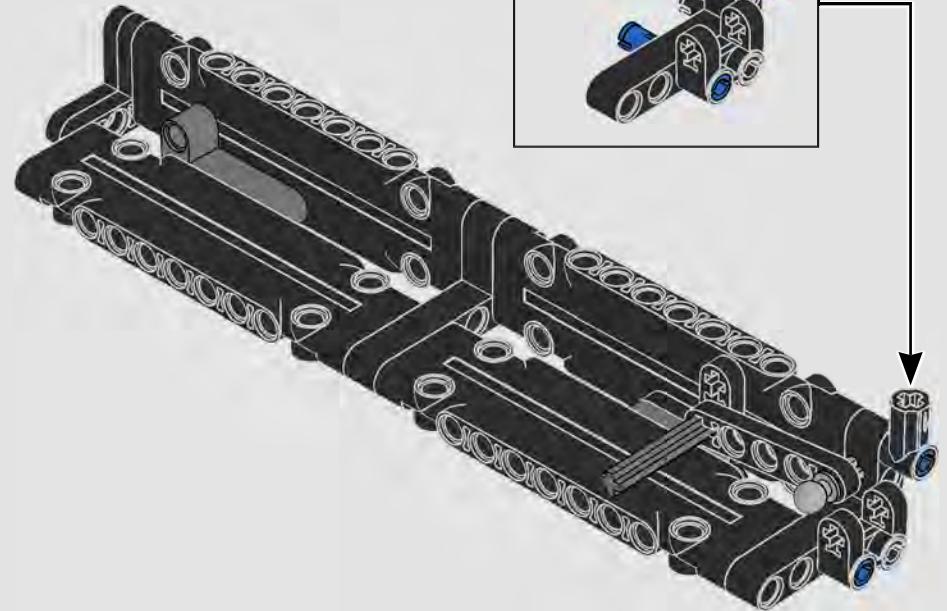
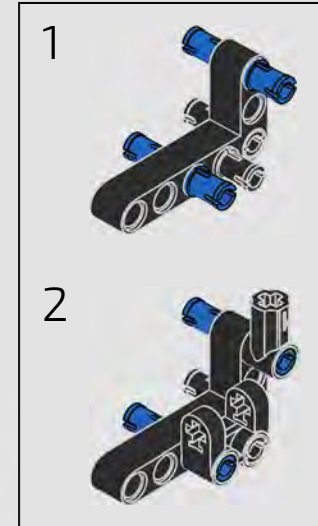

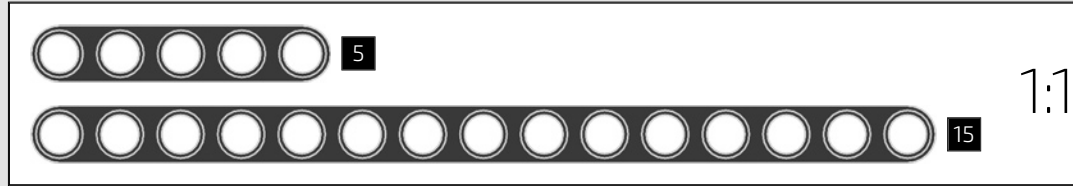
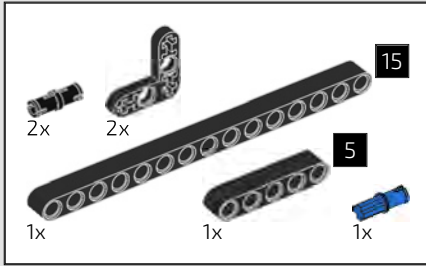

460

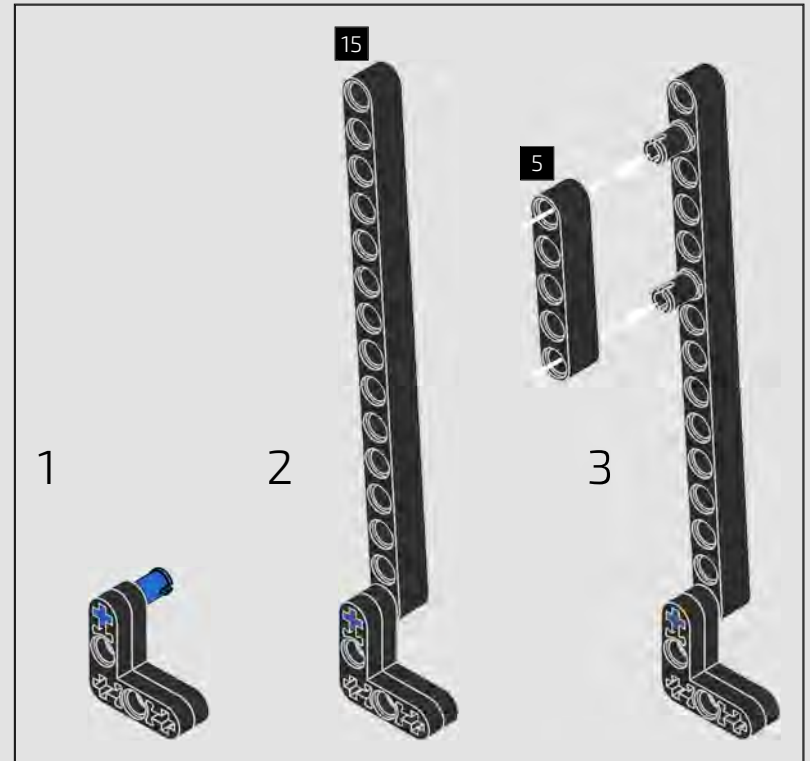
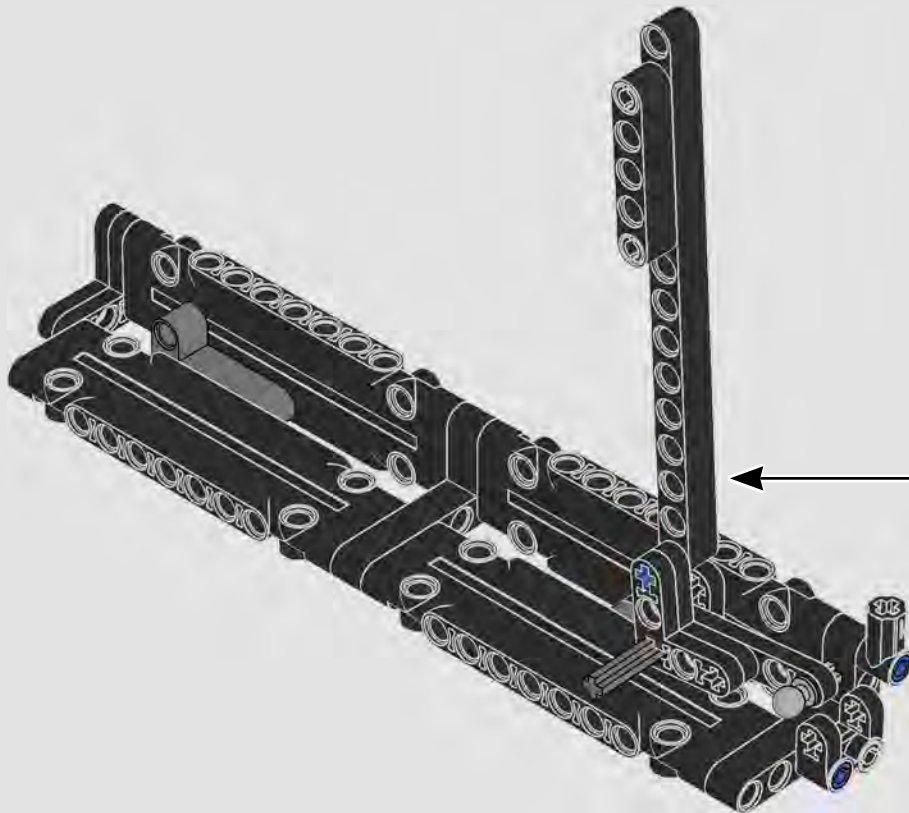



461

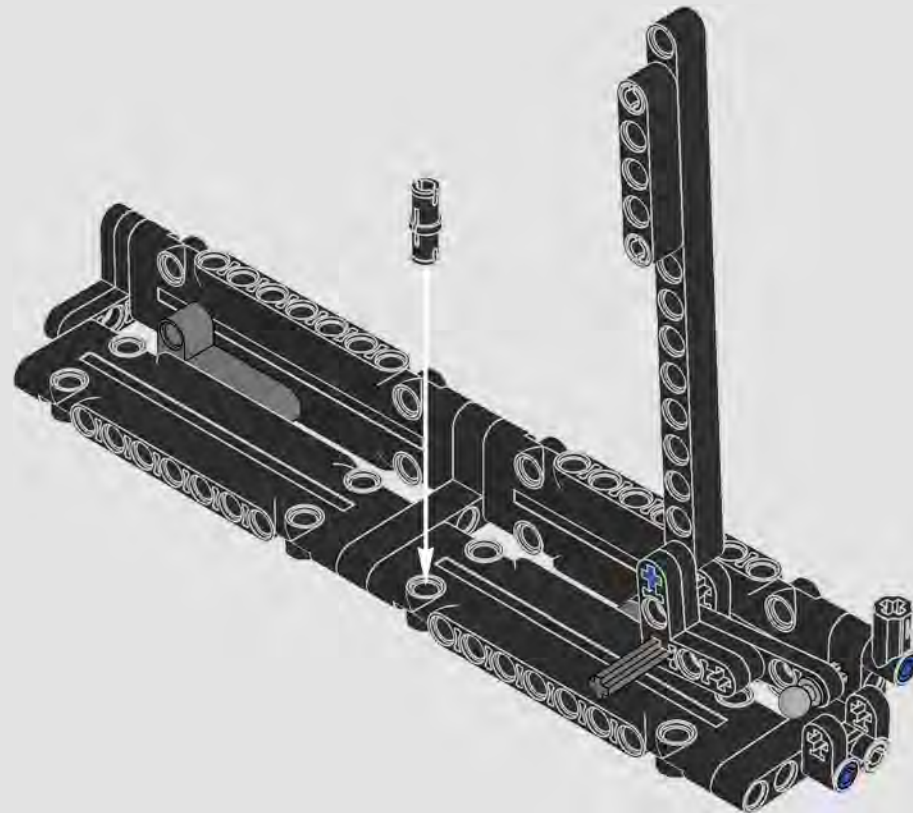

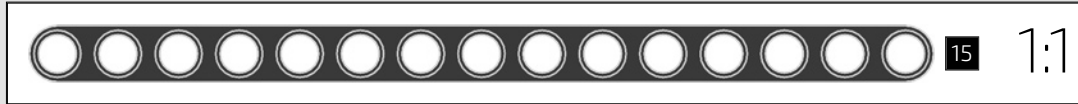
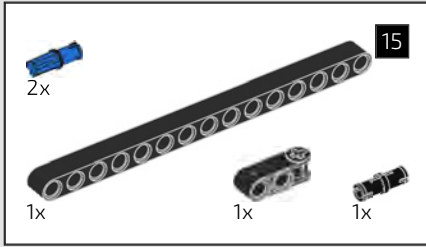

462

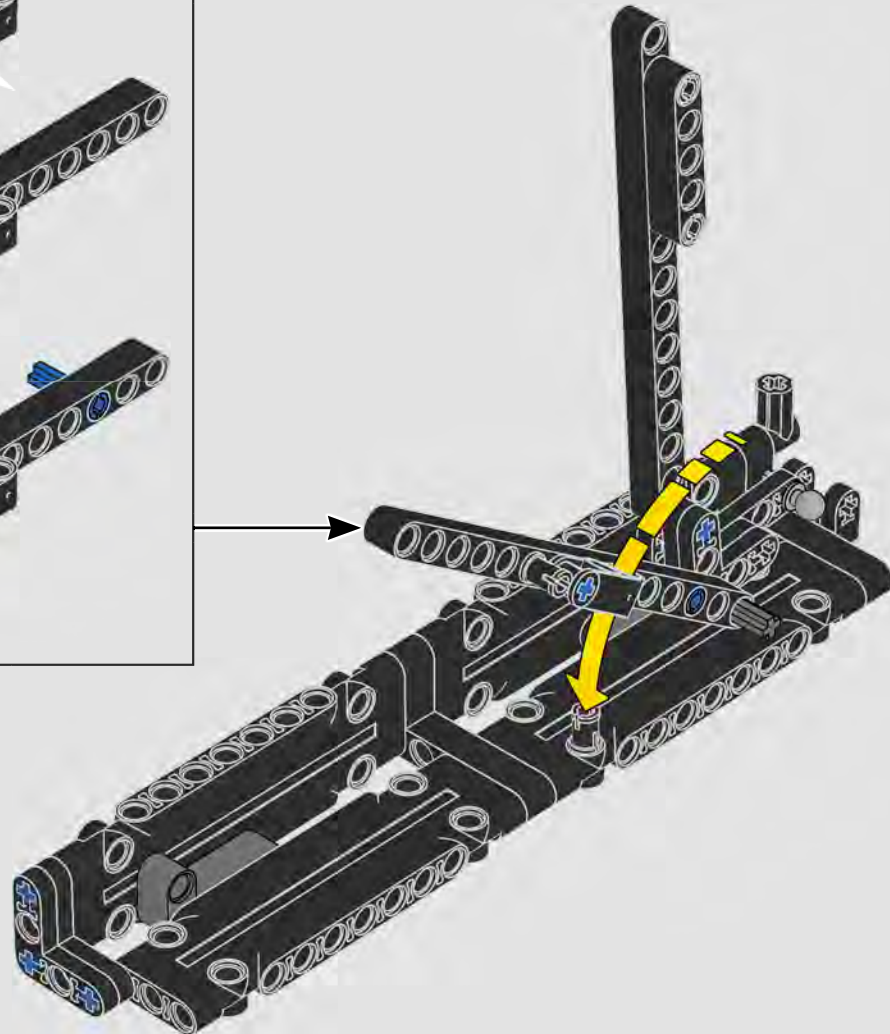
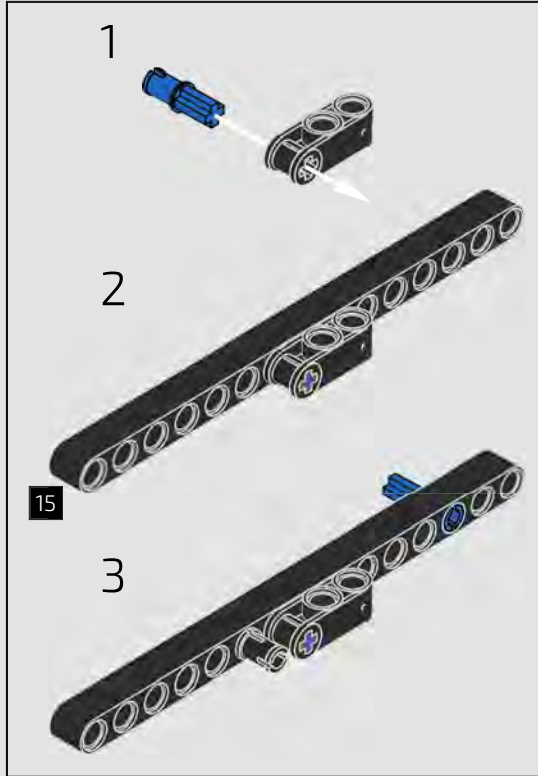

463

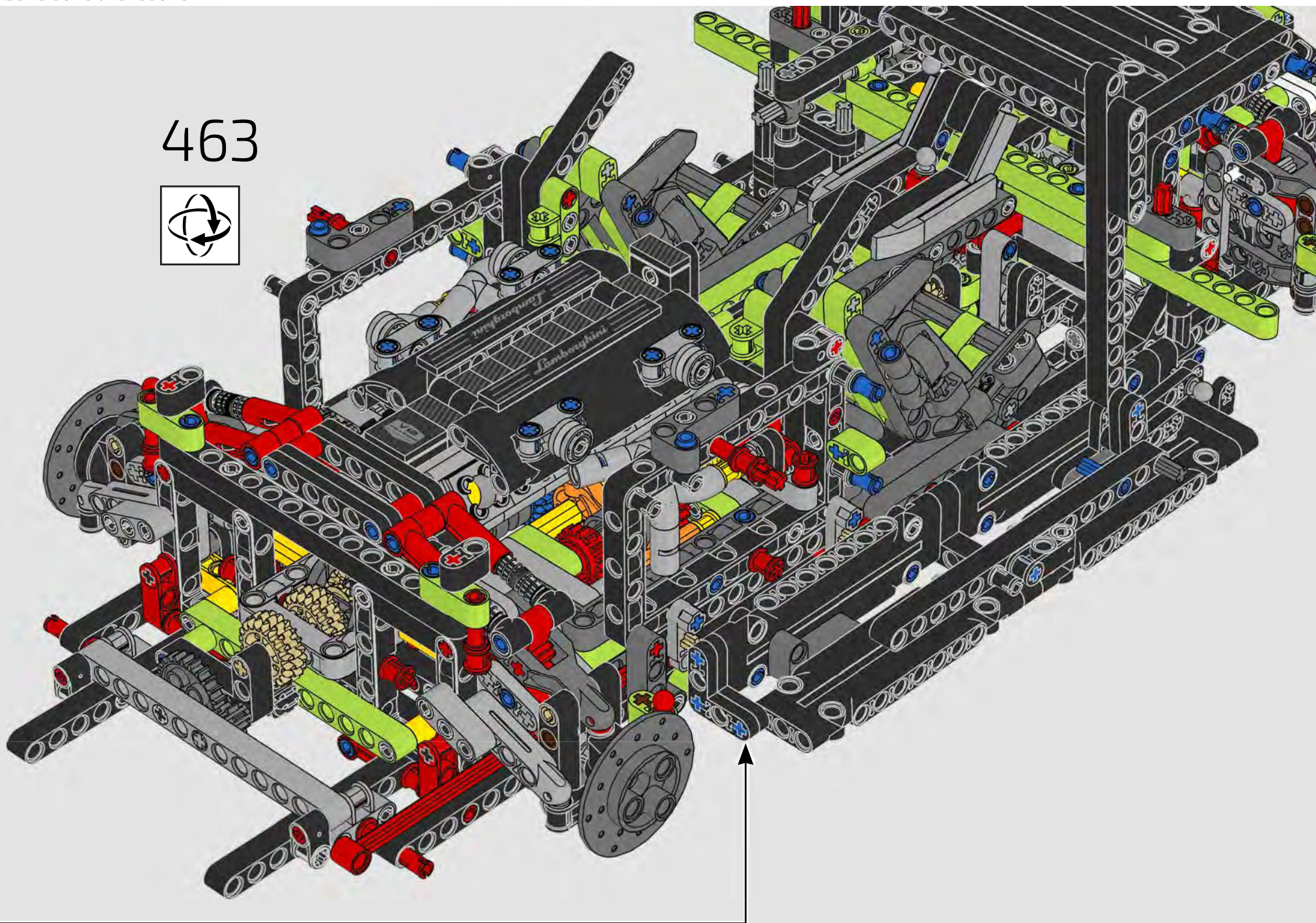
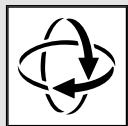

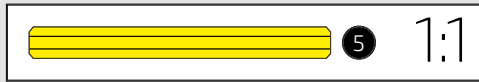
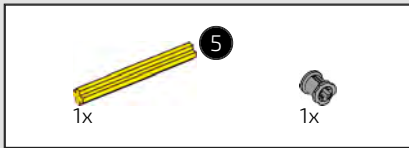

464

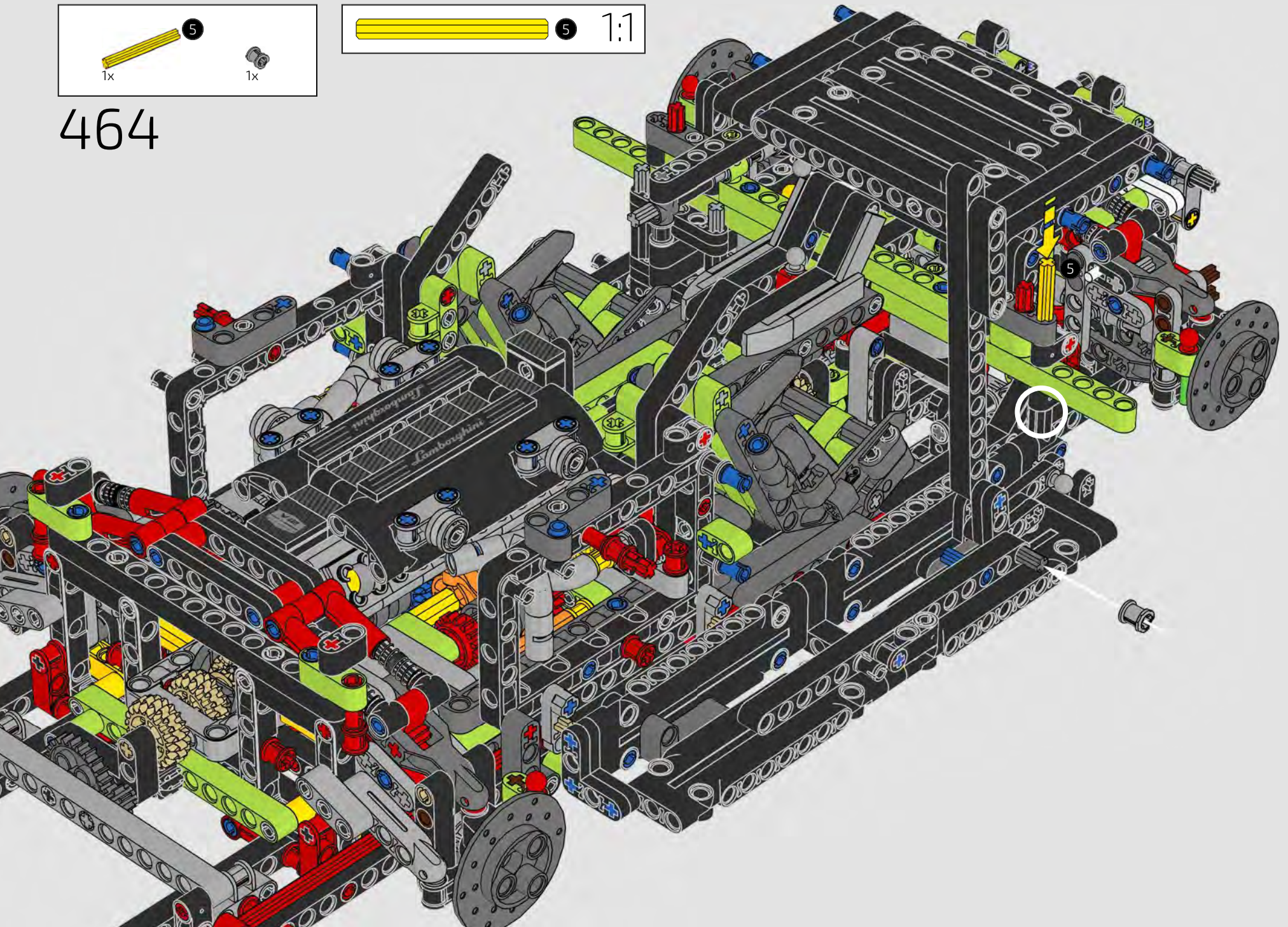

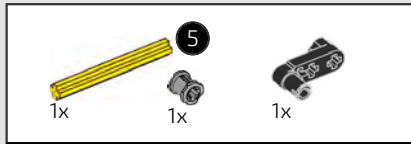

465

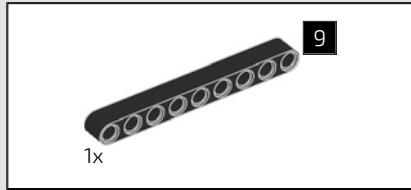
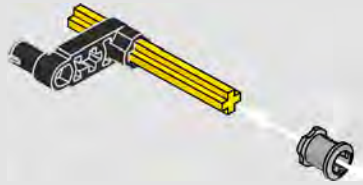
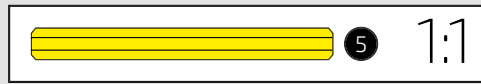

466

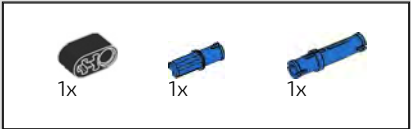

467

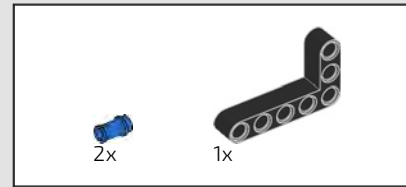

468

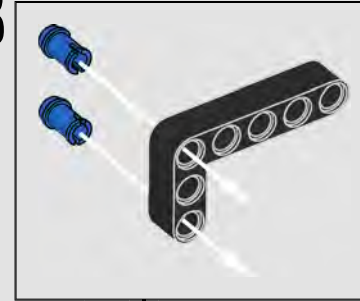

469



470

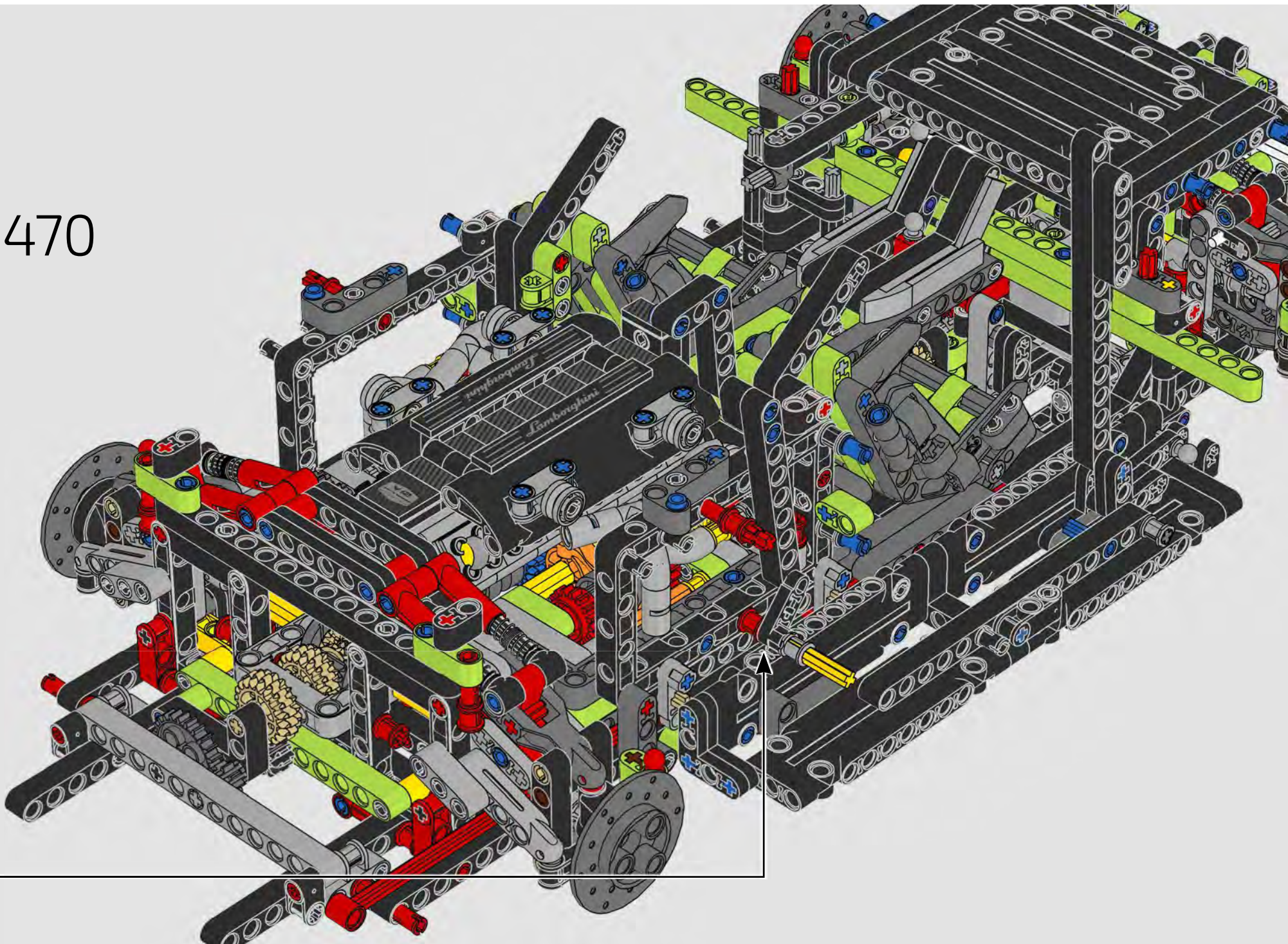

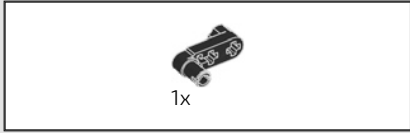

471

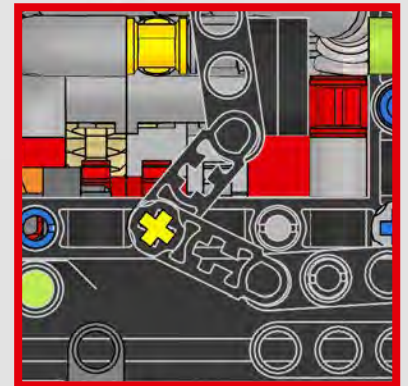
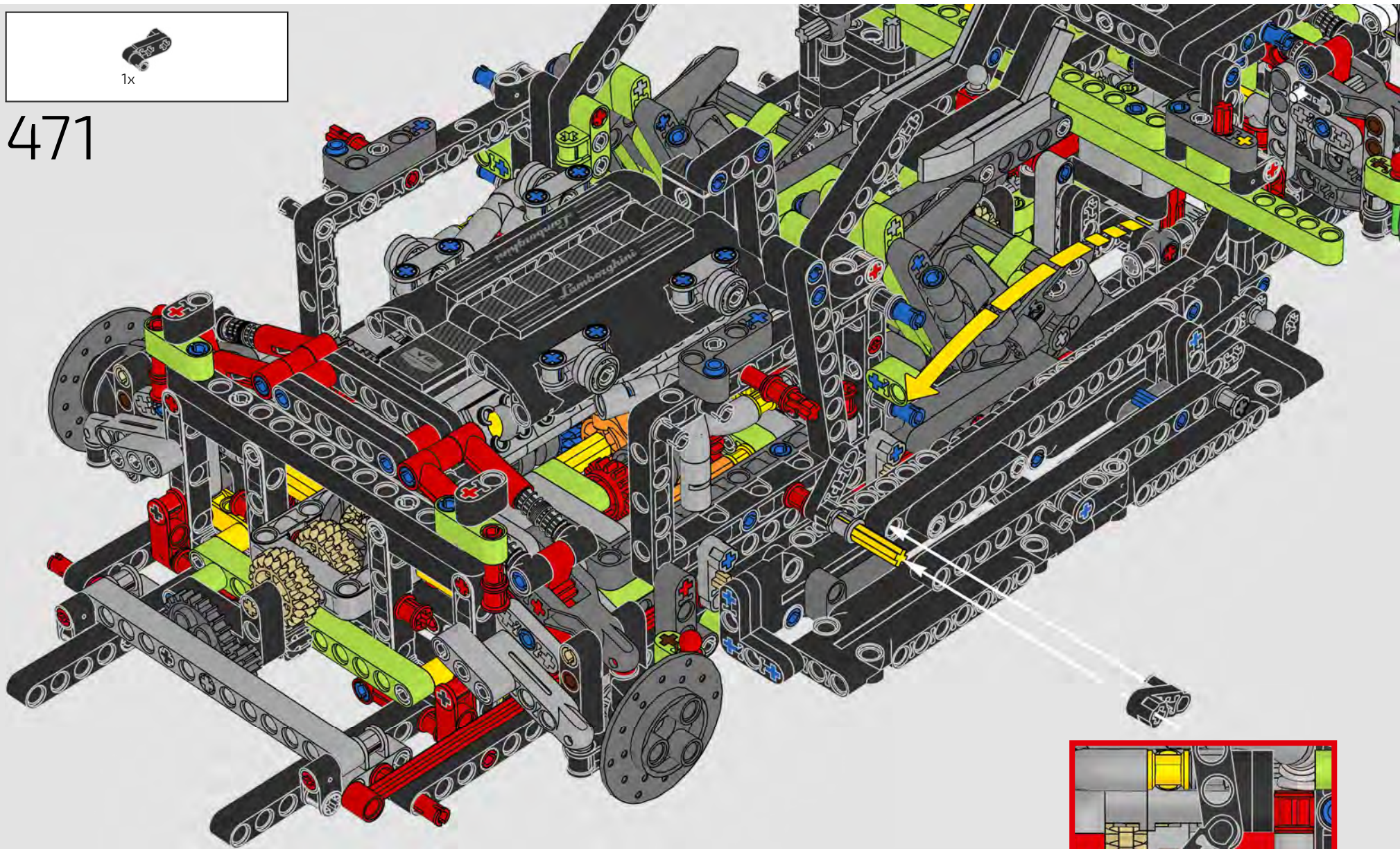

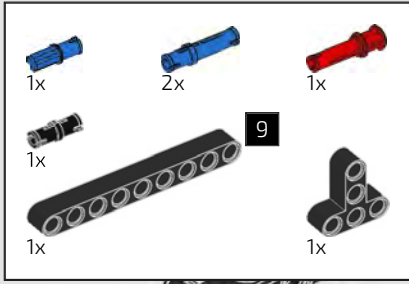

472

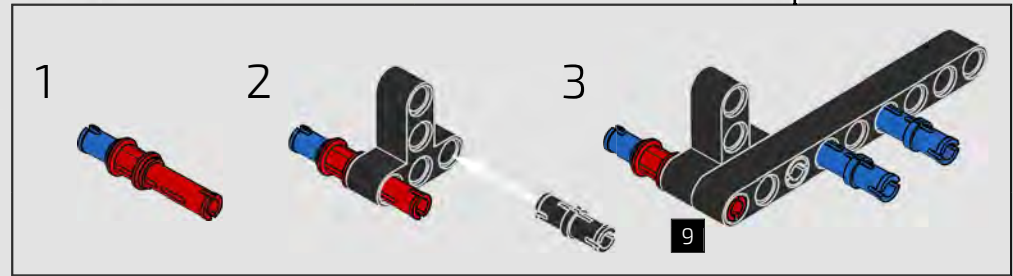
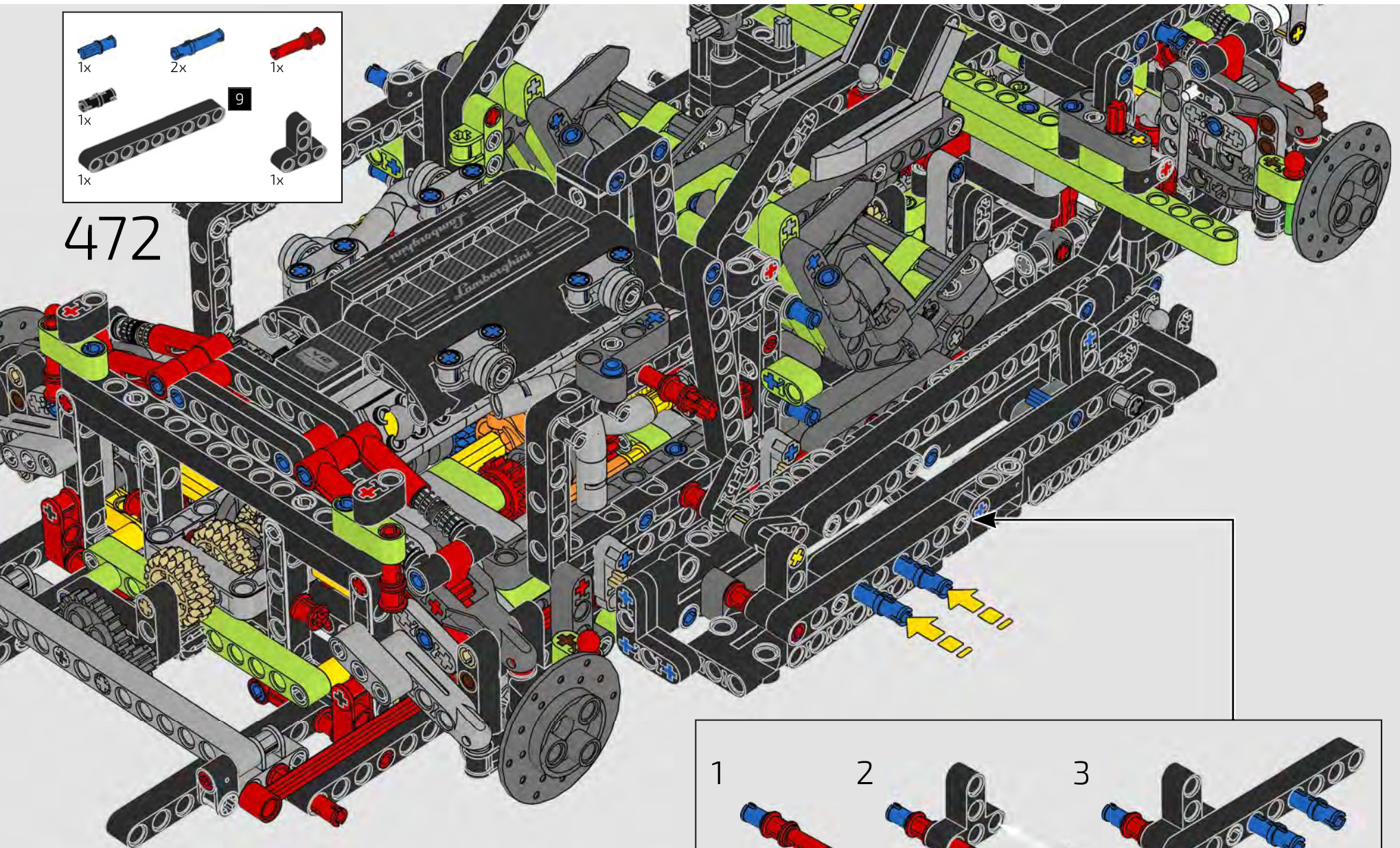

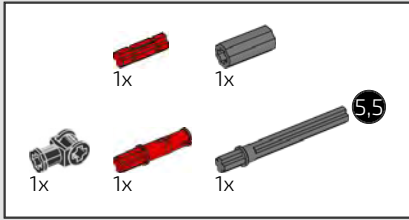

473

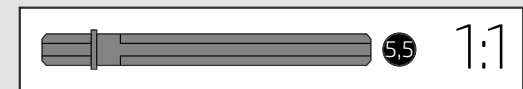
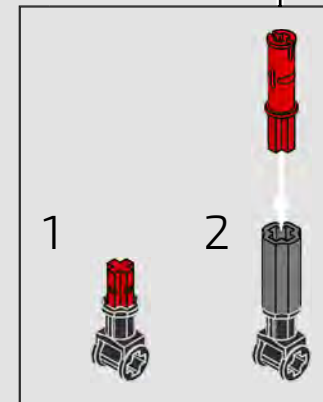
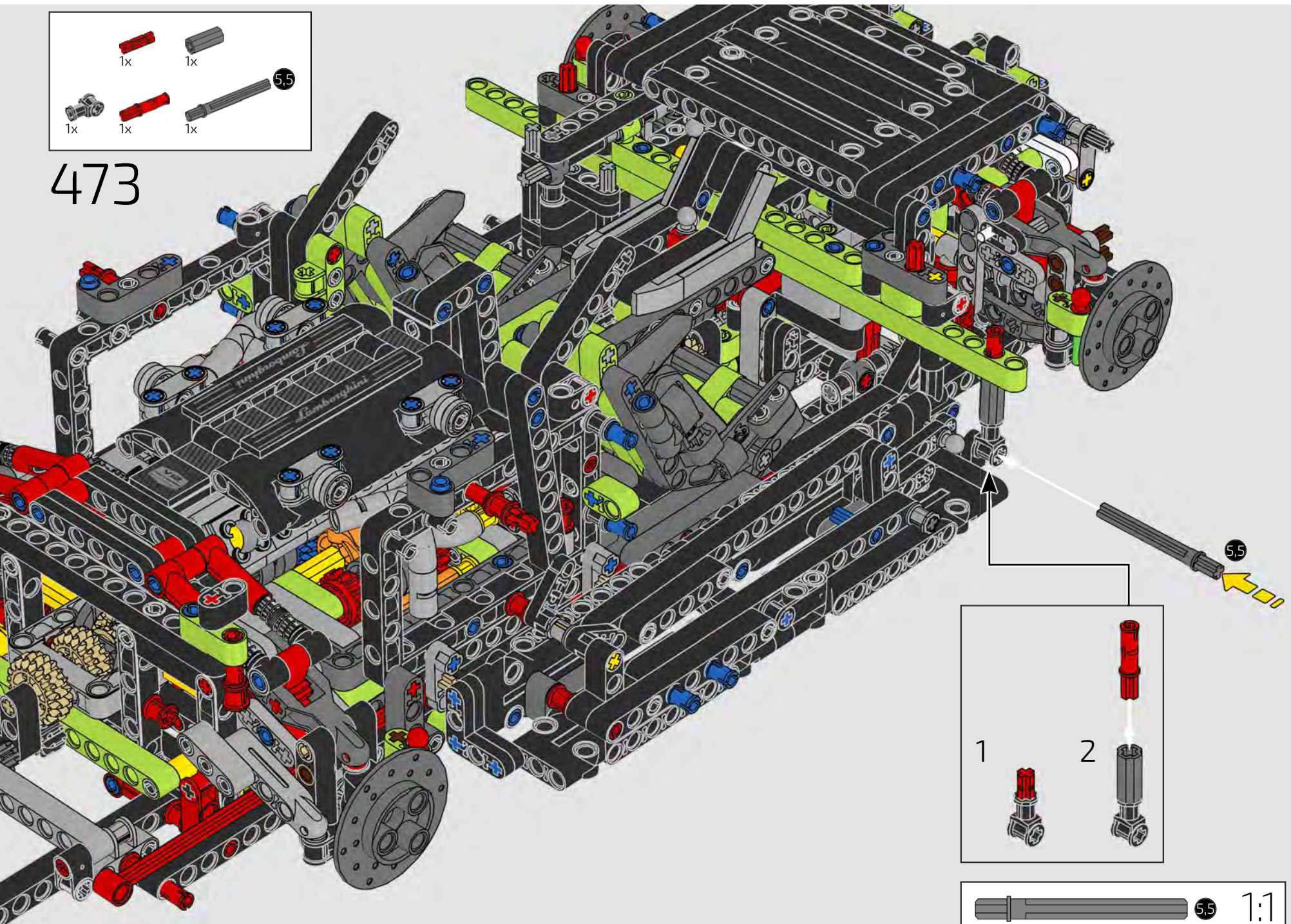

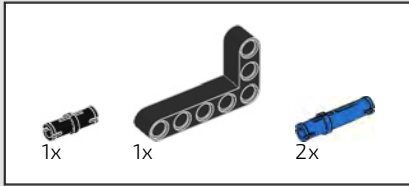

474

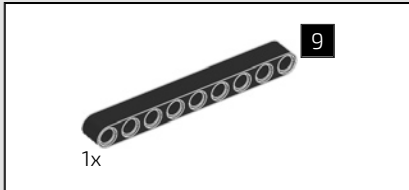

475

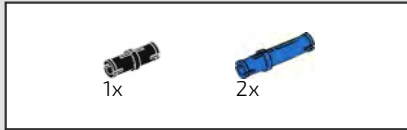

476

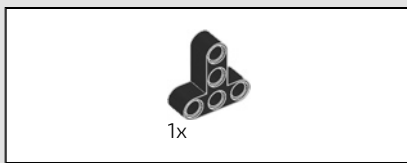

477

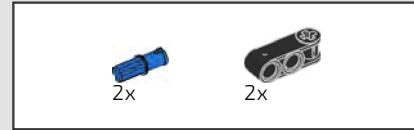
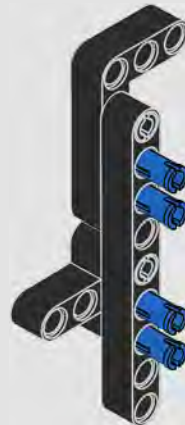

478

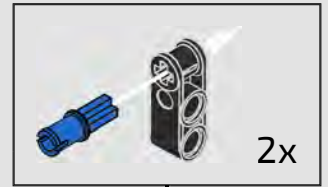
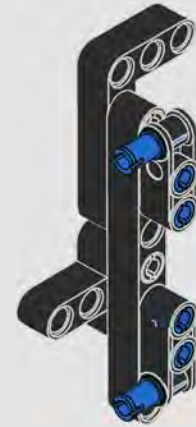

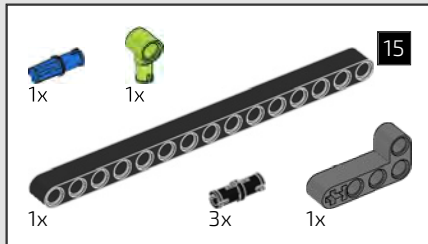

479

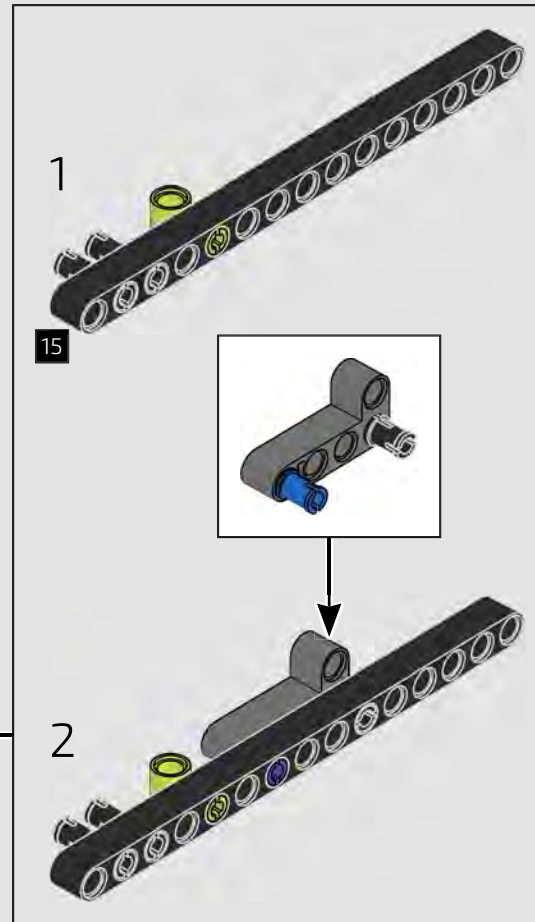
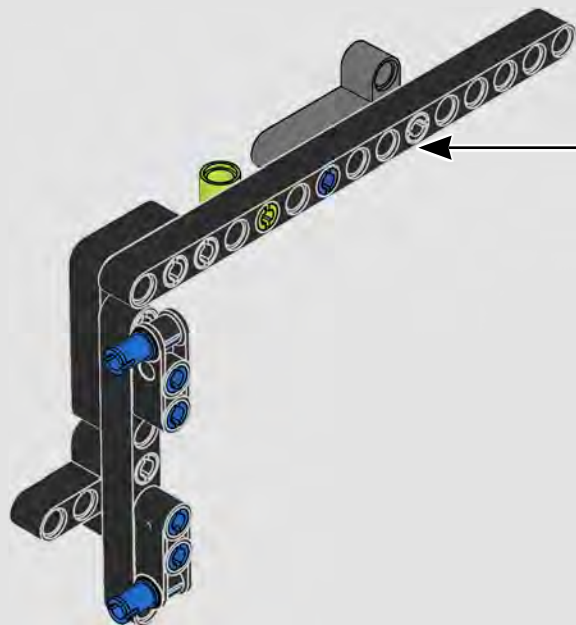

480

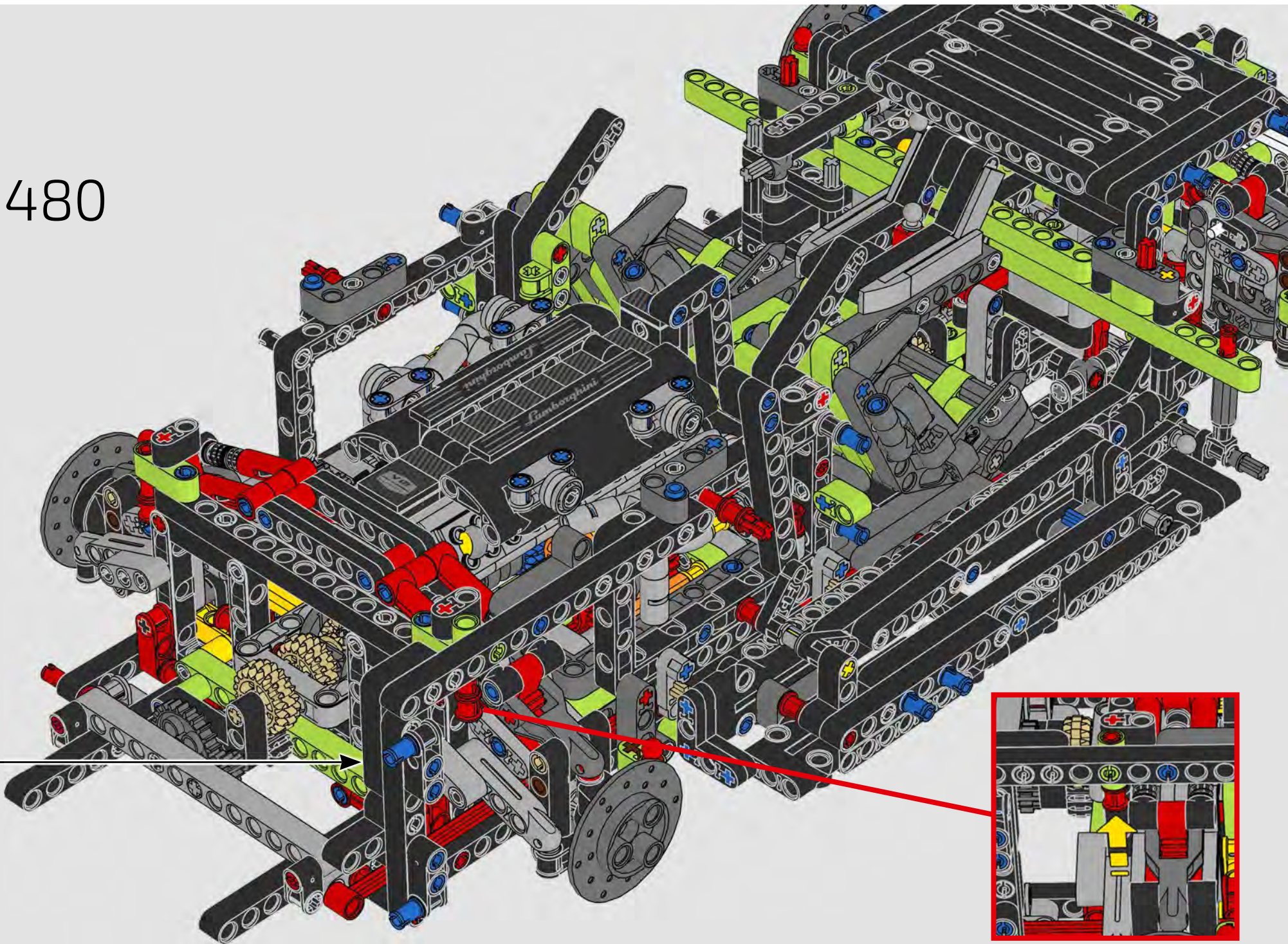

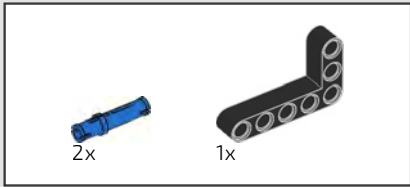
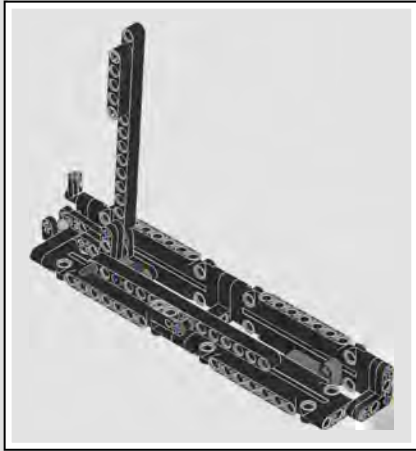

481

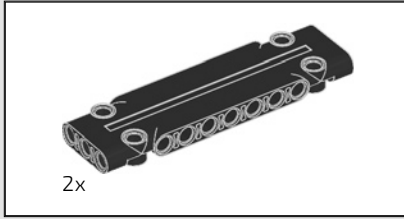

482

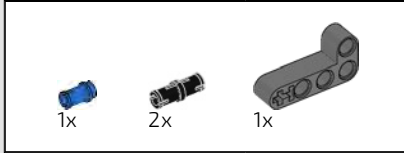
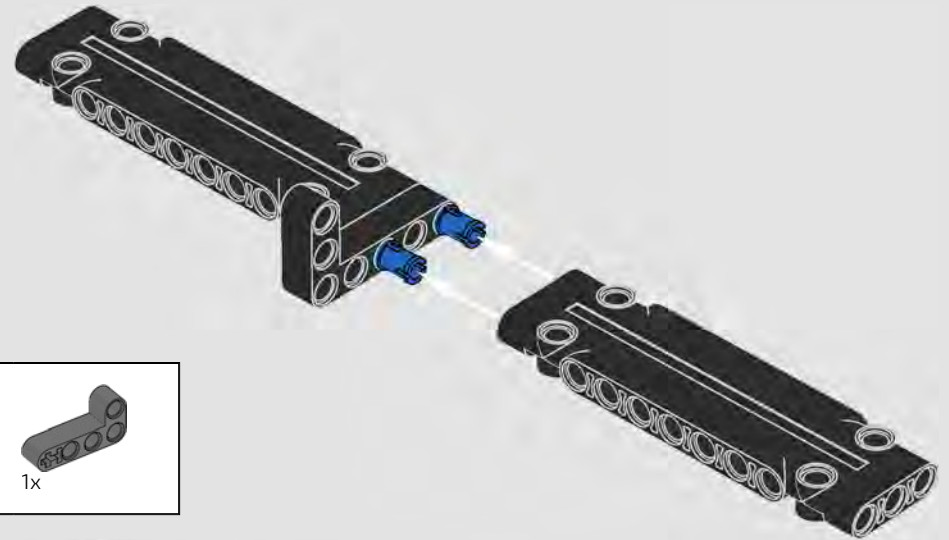

483

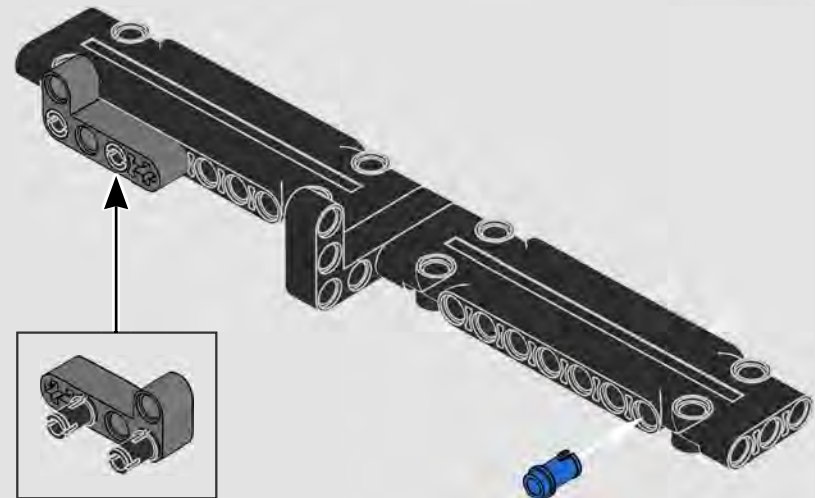

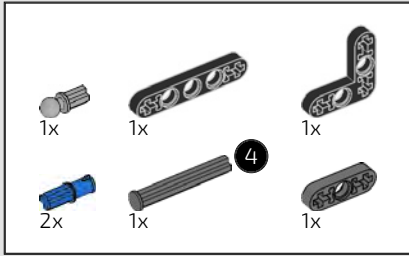

484

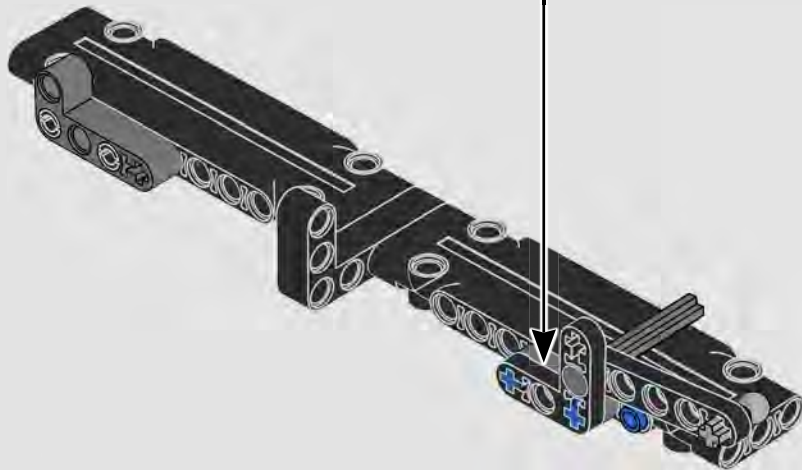
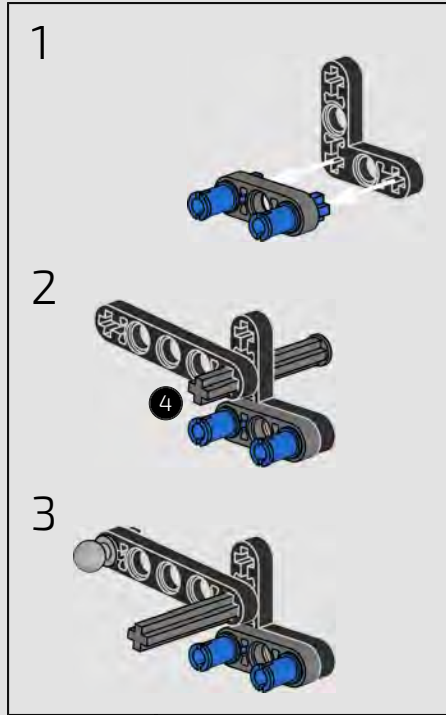
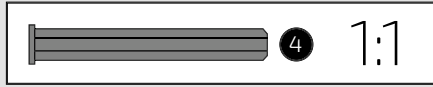
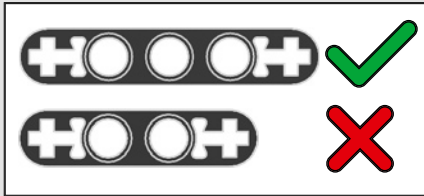

485

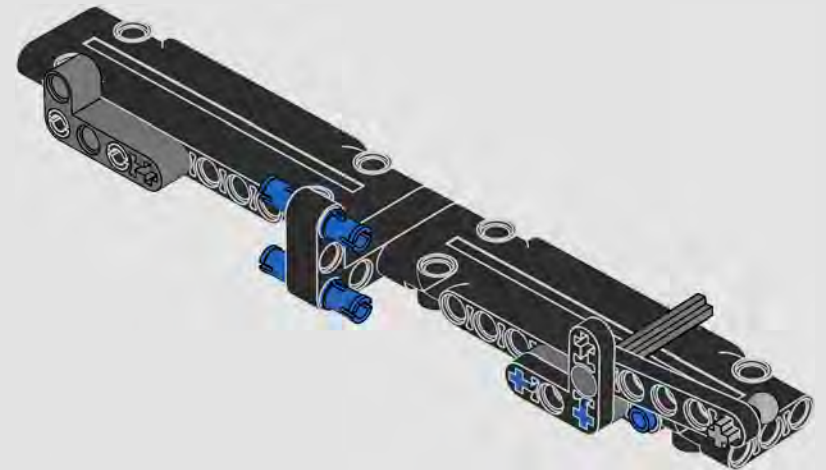

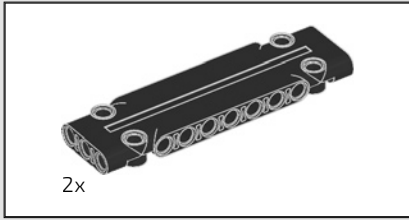

486

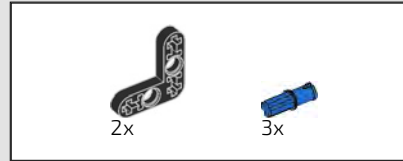
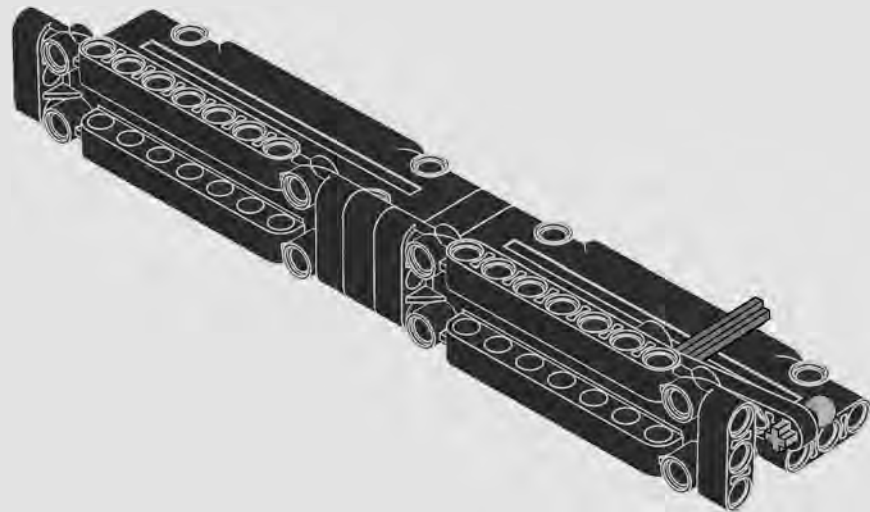

487

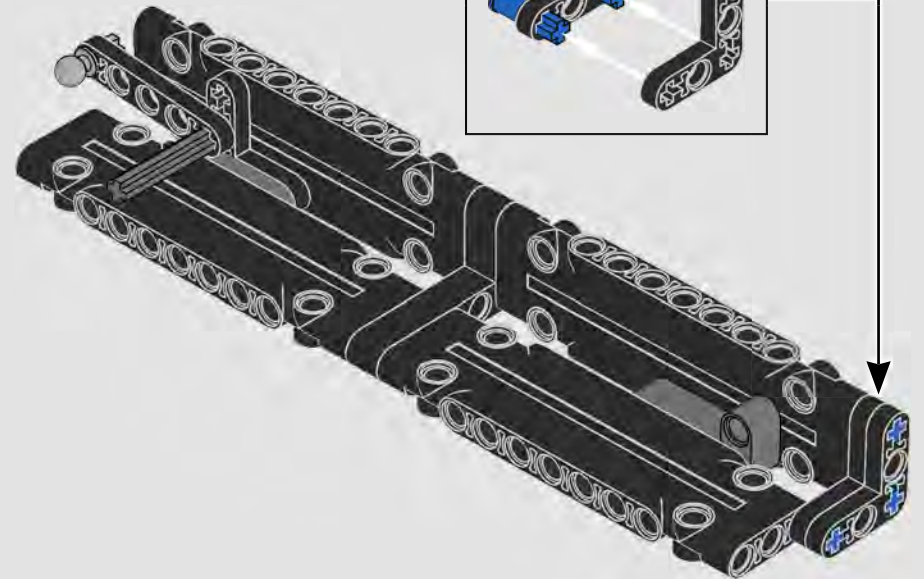
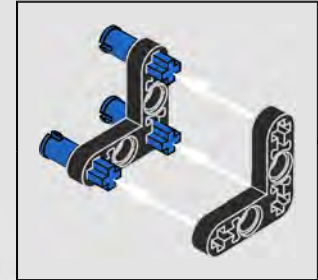

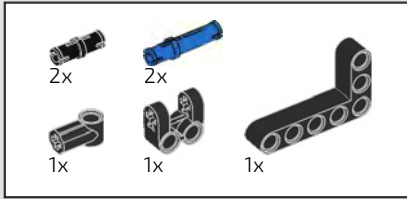

488

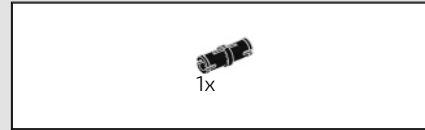
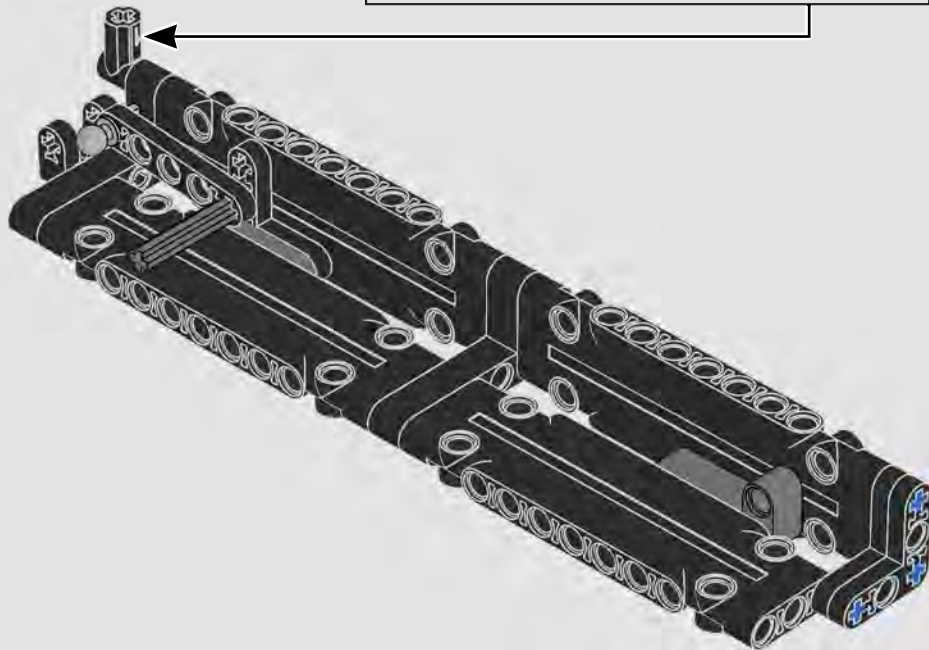
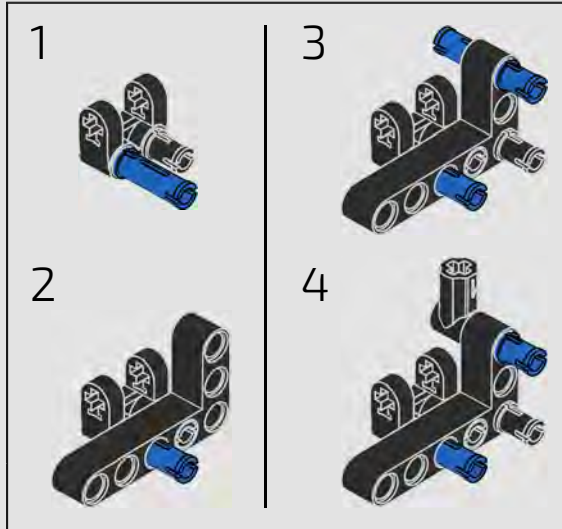

489

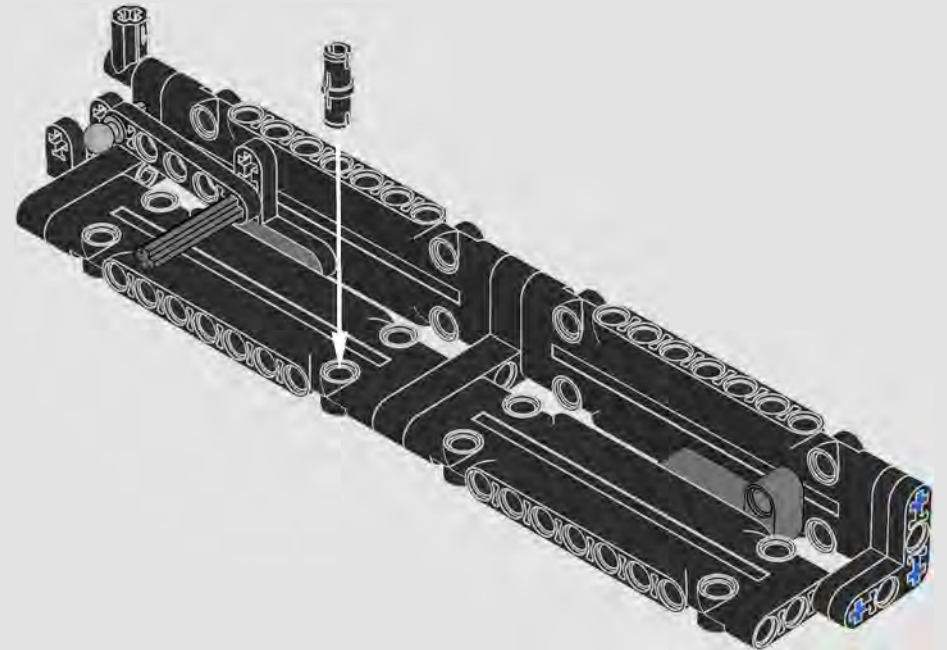

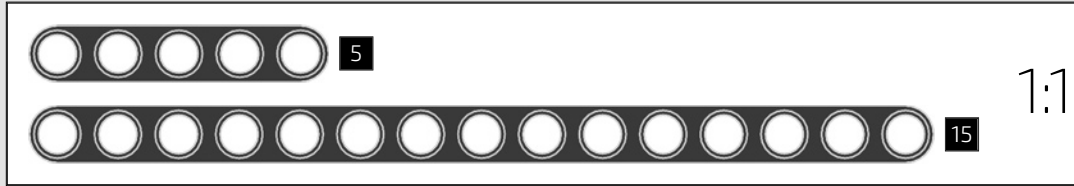
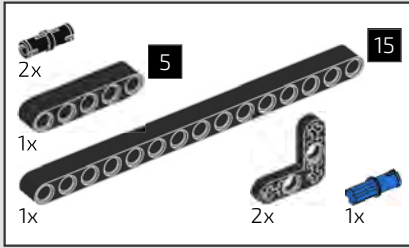

490

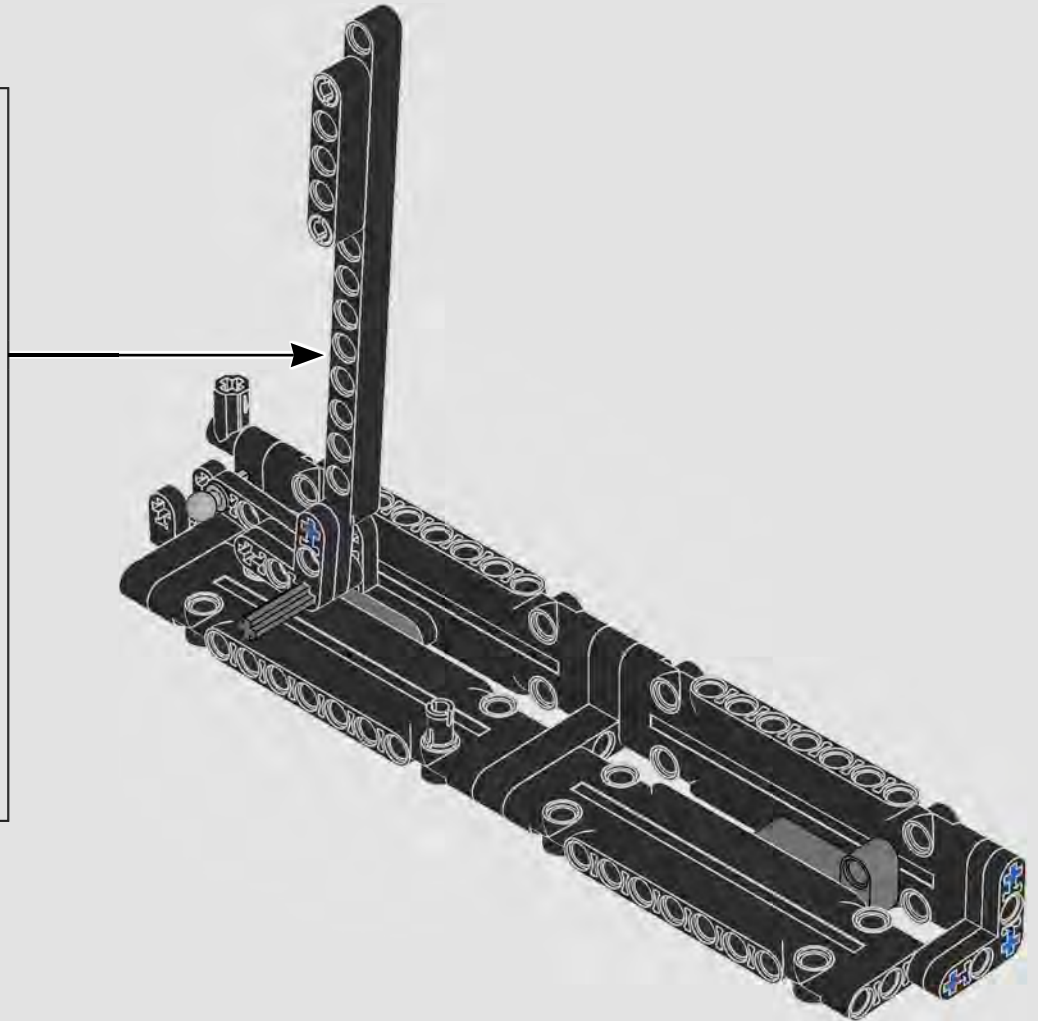
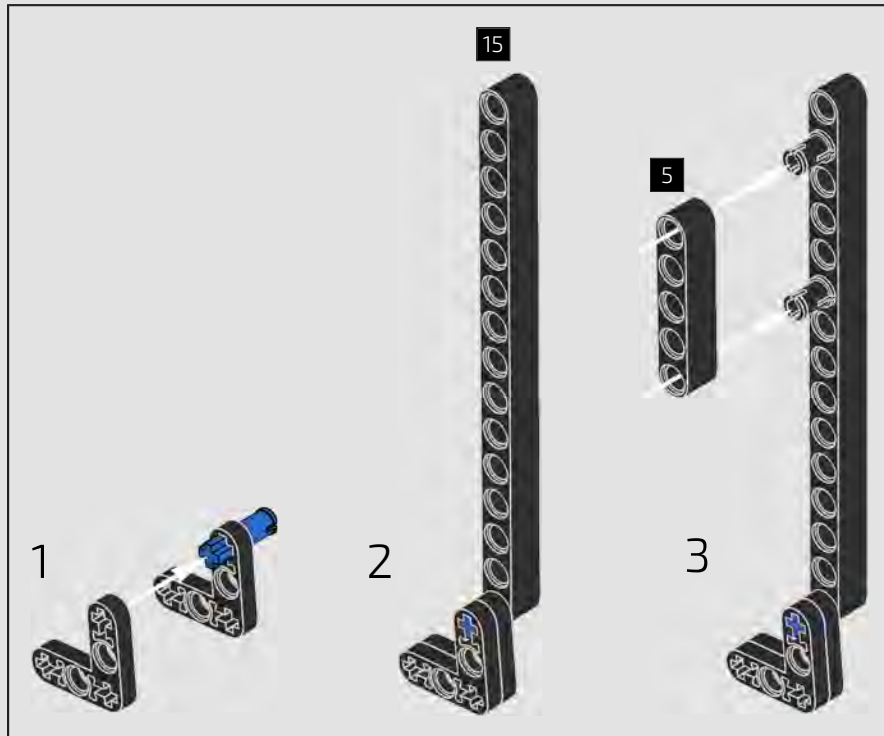

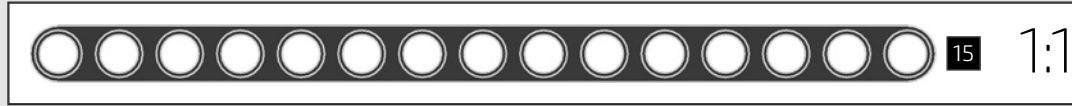
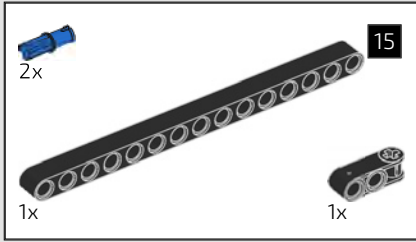

491

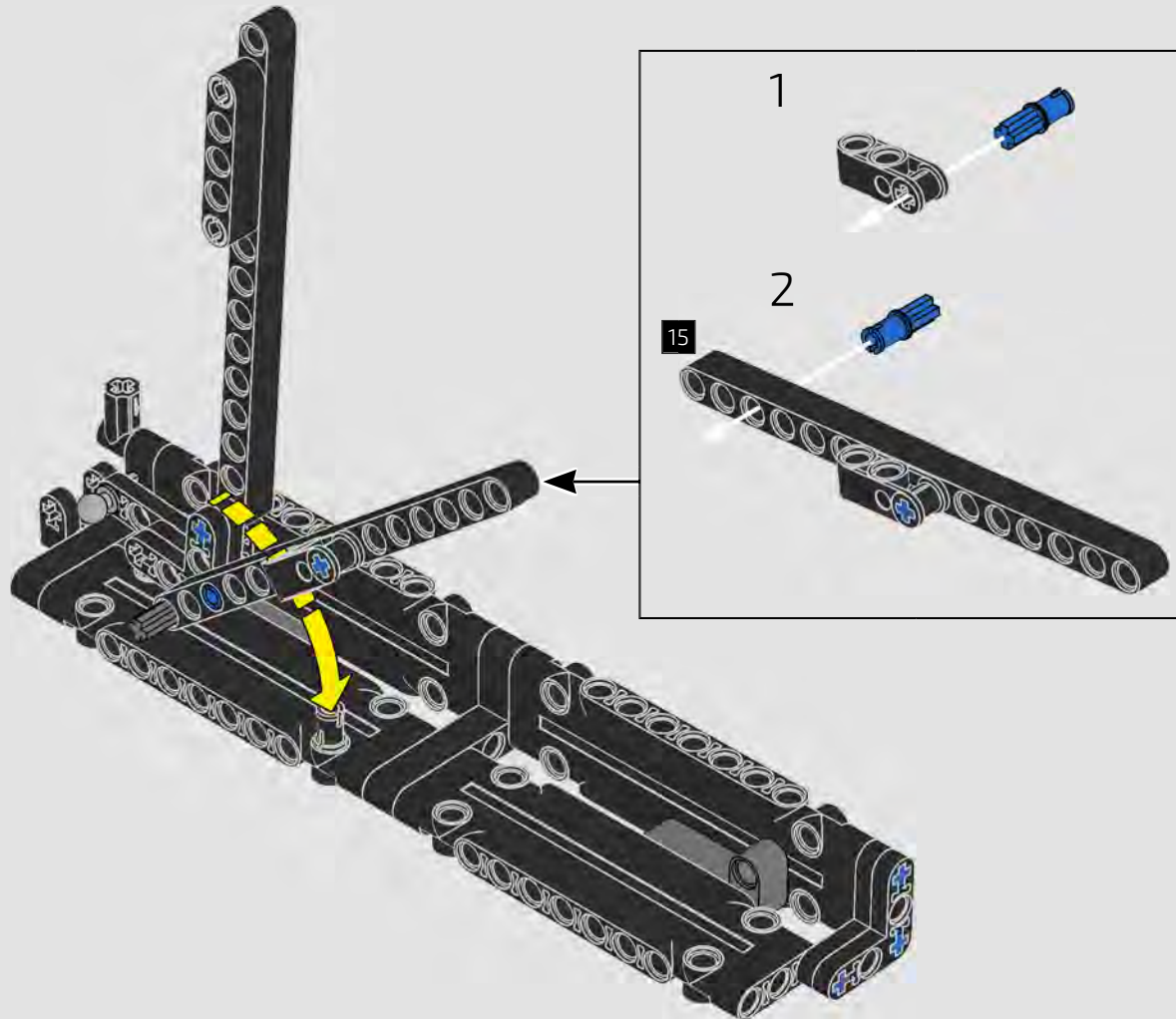



492

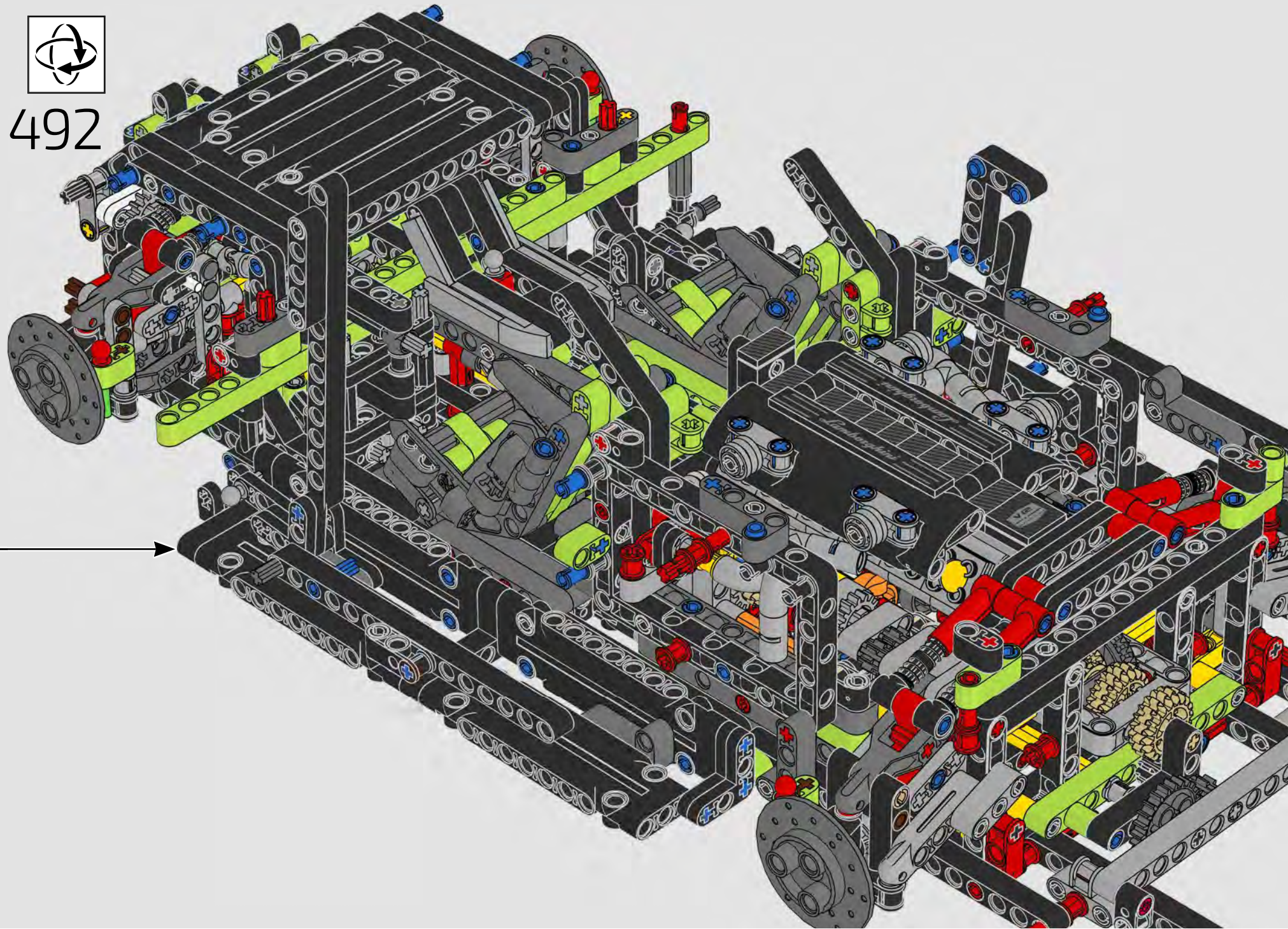

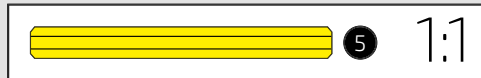
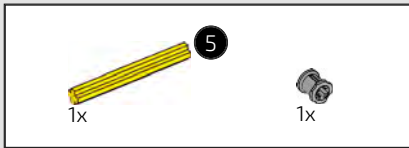

493

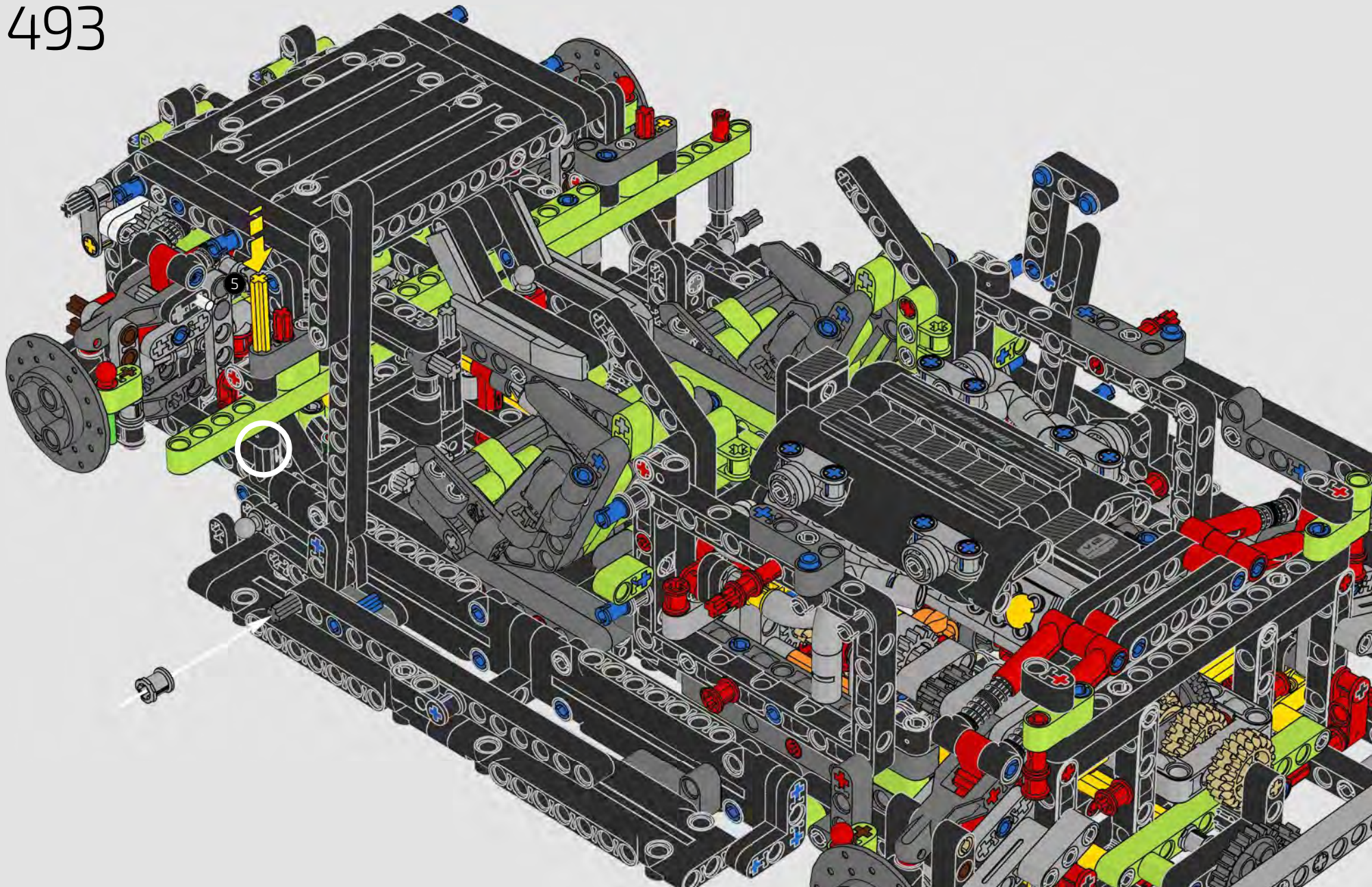

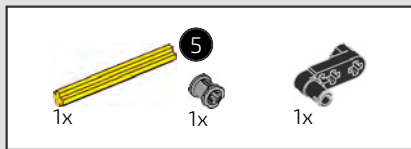

494



495

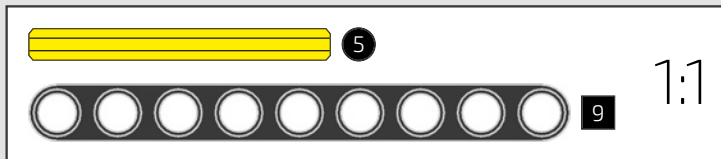

496

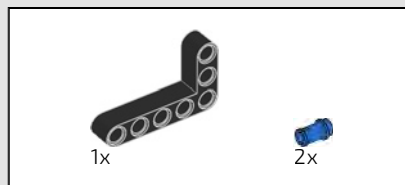

497

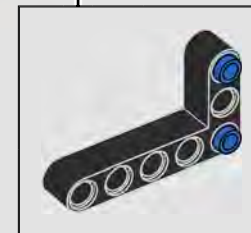
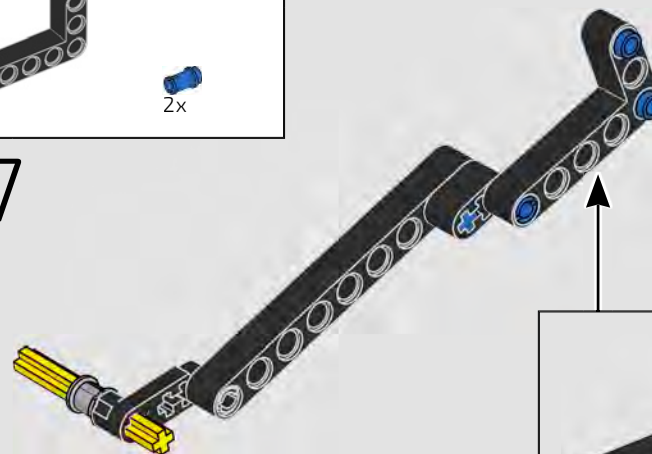

498

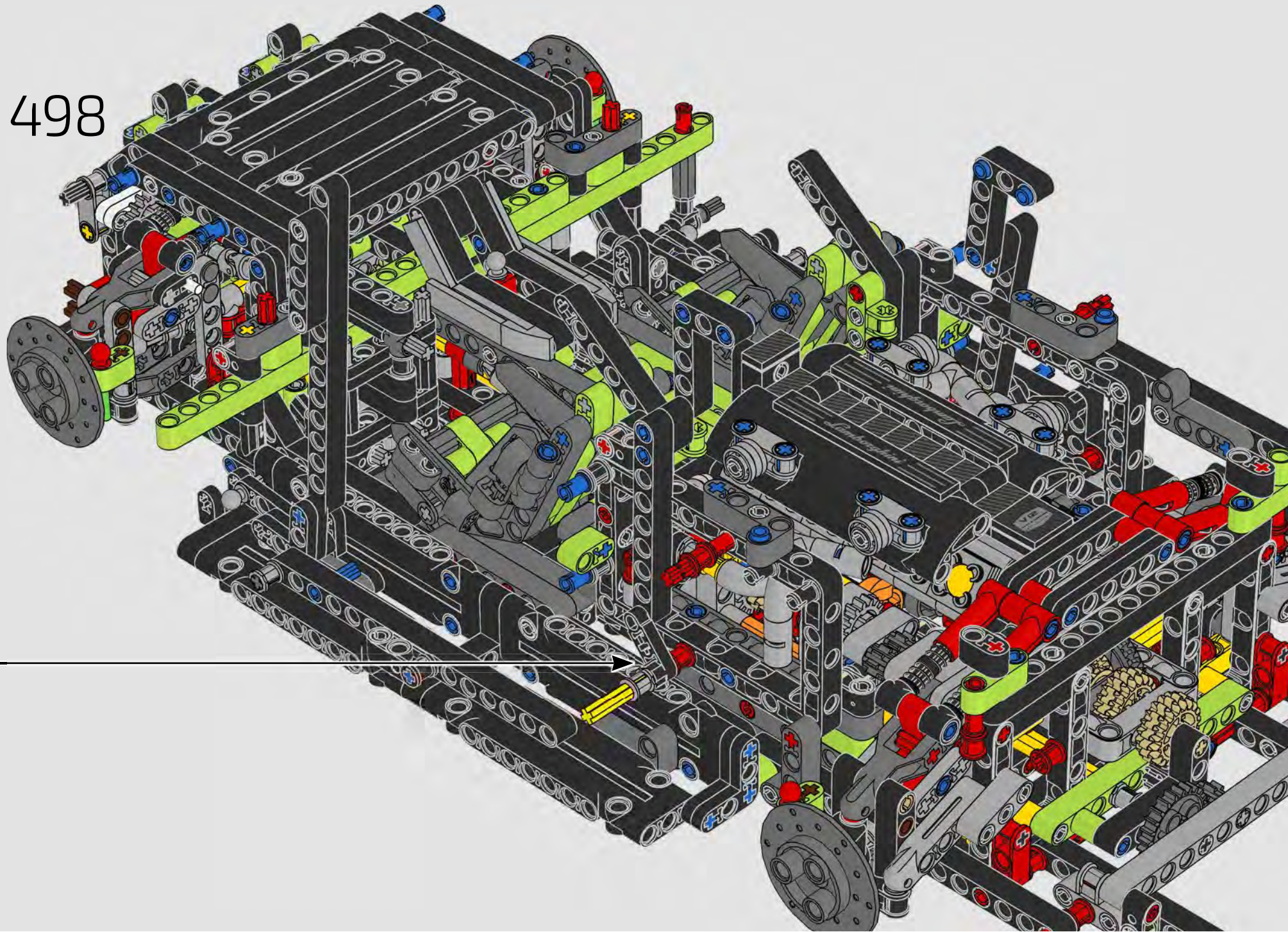

499

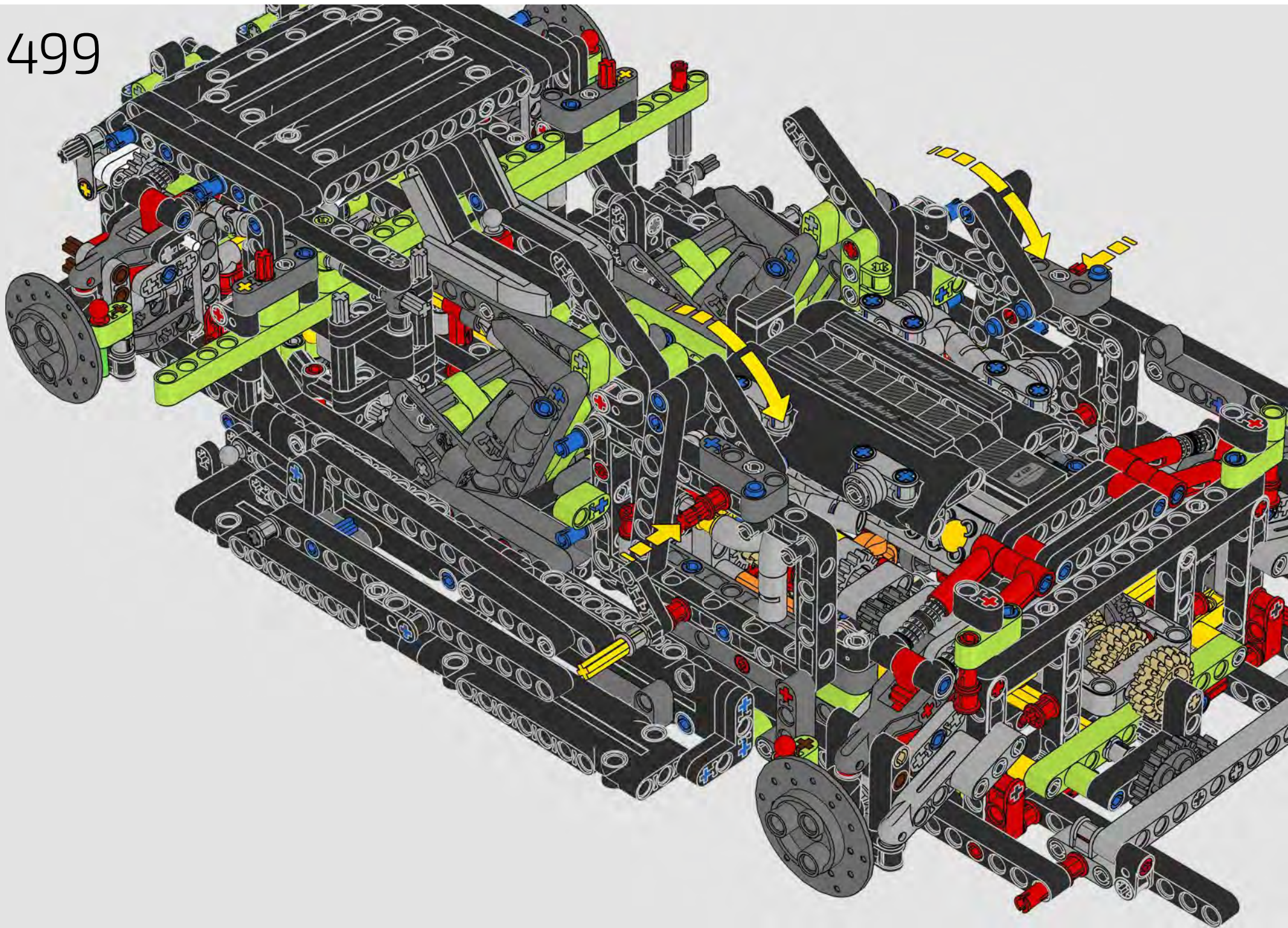

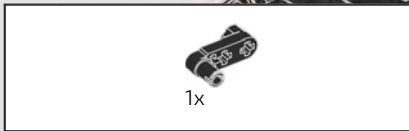

500

